

City of Falcon Heights Planning Commission

City Hall
2077 Larpenteur Avenue West

JOINT WORKSHOP WITH CITY COUNCIL AGENDA

Tuesday, June 12, 2024
6:00 p.m.

A. CALL TO ORDER: 6:00 p.m.

B. ROLL CALL:

Scott Wilson ____	Laura Paynter ____
Jacob Brooks ____	Mike Tracy ____
Jim Mogen ____	Rick Seifert ____
Jake Anderson ____	
Staff Liaison - Hannah Lynch ____	
Council Liaison - Eric Meyer ____	

C. NEW BUSINESS

1. Larpenteur & Snelling Corridor Development Study Update

D. ADJOURN

Next regular meeting date: June 25, 2024



REQUEST FOR COUNCIL ACTION (RCA)

Meeting Date	June 12, 2024
Agenda Item	Policy C1
Attachment(s)	See below.
Submitted By	Hannah Lynch, Community Development Coordinator & Kim Lindquist, WSB

Item	Larpenteur & Snelling Corridor Development Study Update
Description	<p>One of the main goals of the 2040 Comprehensive Plan is “building connections and community identity in Falcon Heights.” A large inhibitor of achieving this goal is the disconnect in the City from Snelling and Larpenteur Avenues. From the 2040 Comprehensive Plan:</p> <p><i>Built to encourage vehicle rather than pedestrian traffic, Larpenteur and Snelling also function as significant barriers between neighborhoods, fragmenting city identity. Yet these major thoroughfares offer enormous potential to become the keys to a stronger civic identity, a sense of arrival and welcome, connection and community. In-depth study of these corridors is needed in order to formulate corridor framework plans to guide public and private development aimed at realizing this potential.</i></p> <p>The Larpenteur & Snelling Corridor Development Study has held two community meetings and one business meeting, gathering feedback from residents and business owners in the City. WSB has collected this feedback and has created concepts for review.</p>
Budget Impact	N/A
Attachment(s)	<ul style="list-style-type: none"> • Draft – WSB Concept Plans for Larpenteur & Snelling Corridor Development Study
Action(s) Requested	The City Council is requested to review the materials and provide feedback on the progression of the study.

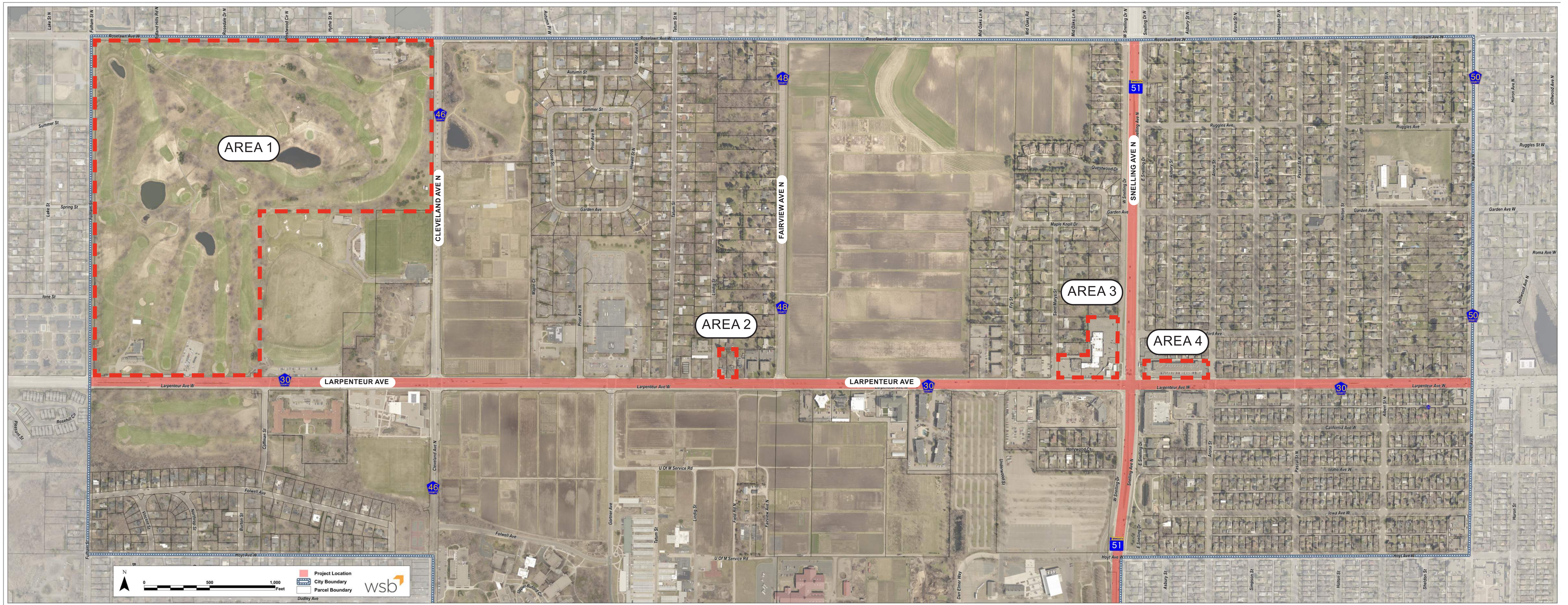

Snelling Larpenteur Corridor Study | Overall Map

Falcon Heights, MN

June 4, 2024 | WSB Project number: 023472-000

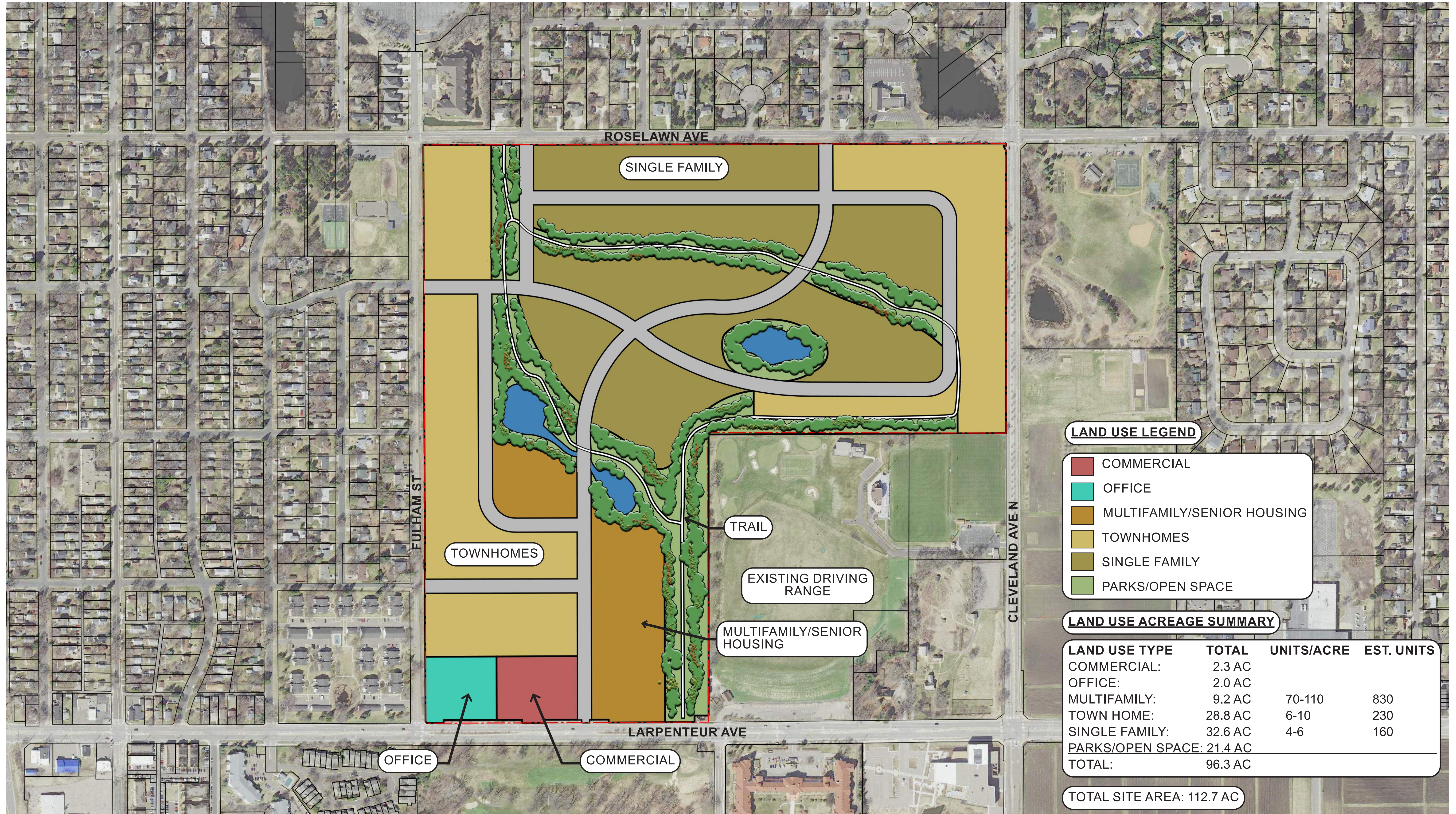

Snelling Larpenteur Corridor Study | Area 1: Option A

Falcon Heights, MN

June 4, 2024 | WSB Project number: 023472-000

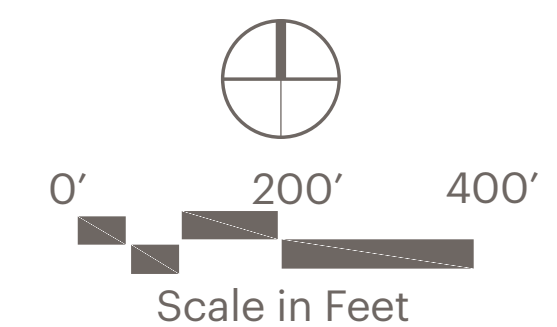

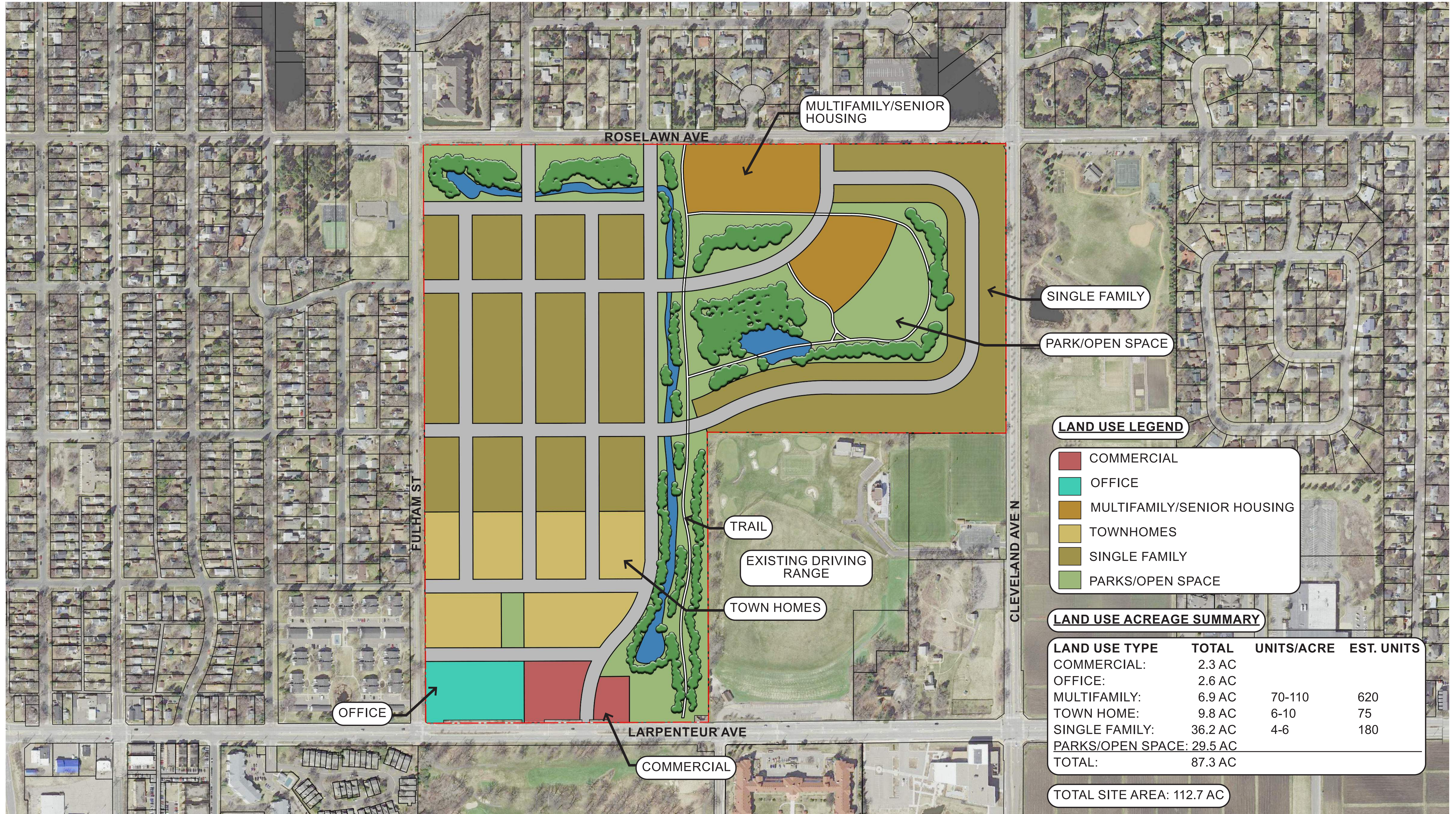

LAND USE LEGEND

- COMMERCIAL
- OFFICE
- MULTIFAMILY/SENIOR HOUSING
- TOWNHOMES
- SINGLE FAMILY
- PARKS/OPEN SPACE

LAND USE ACREAGE SUMMARY

LAND USE TYPE	TOTAL	UNITS/ACRE	EST. UNITS
COMMERCIAL:	2.3 AC		
OFFICE:	2.6 AC		
MULTIFAMILY:	6.9 AC	70-110	620
TOWN HOME:	9.8 AC	6-10	75
SINGLE FAMILY:	36.2 AC	4-6	180
PARKS/OPEN SPACE:	29.5 AC		
TOTAL:	87.3 AC		

TOTAL SITE AREA: 112.7 AC

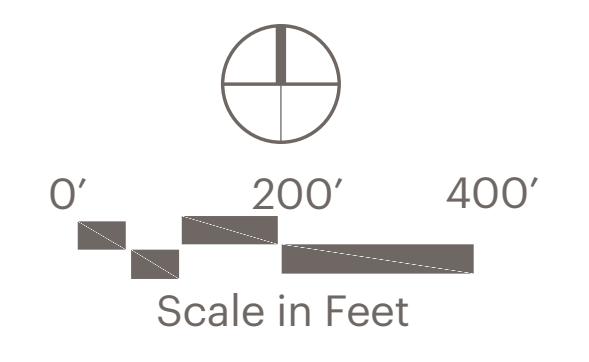

Snelling Larpenteur Corridor Study | Area 1: Option B

Falcon Heights, MN
 June 4, 2024 | WSB Project number: 023472-000

K:\023472-000\Graphics\Concepts\023472-000 Snelling Larpenteur Corridor Study

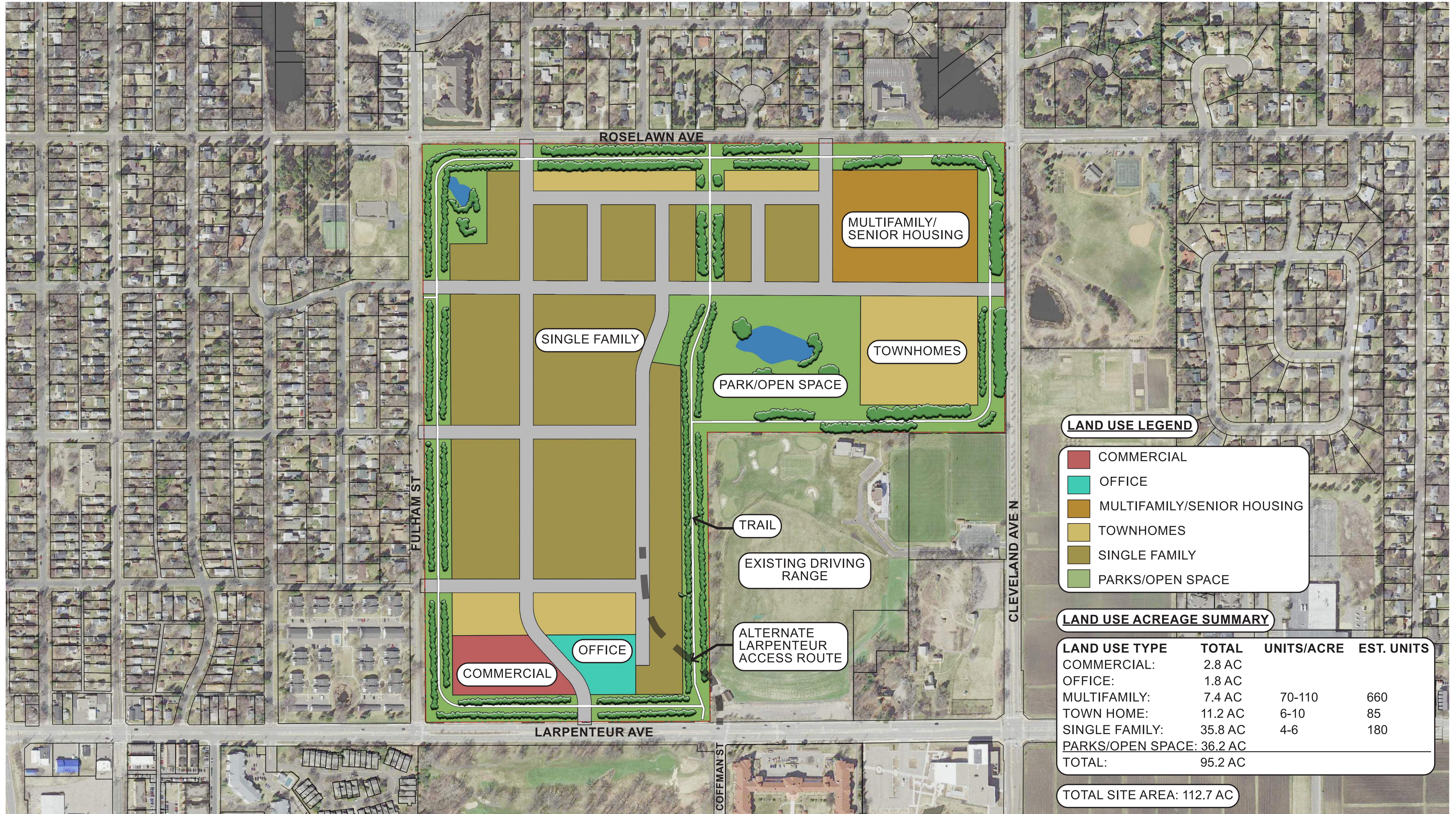

LAND USE LEGEND

- COMMERCIAL
- OFFICE
- MULTIFAMILY/SENIOR HOUSING
- TOWNHOMES
- SINGLE FAMILY
- PARKS/OPEN SPACE

LAND USE ACREAGE SUMMARY

LAND USE TYPE	TOTAL	UNITS/ACRE	EST. UNITS
COMMERCIAL:	2.8 AC		
OFFICE:	1.8 AC		
MULTIFAMILY:	7.4 AC	70-110	660
TOWN HOME:	11.2 AC	6-10	85
SINGLE FAMILY:	35.8 AC	4-6	180
PARKS/OPEN SPACE:	36.2 AC		
TOTAL:	95.2 AC		

TOTAL SITE AREA: 112.7 AC

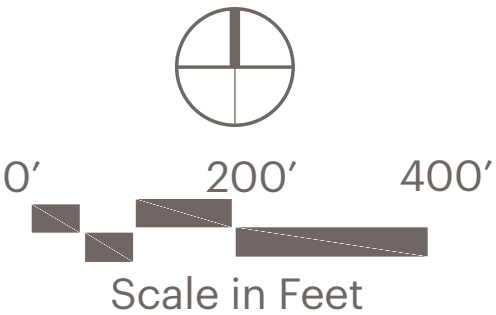

Snelling Larpenteur Corridor Study | Area 1: Option C

Falcon Heights, MN
 June 4, 2024 | WSB Project number: 023472-000



K:\023472-000\Graphics\Concepts\023472-000 Snelling Larpenteur Corridor Study

Snelling Larpenteur Corridor Study | Area 2: Option A

Falcon Heights, MN
June 4, 2024 | WSB Project number: 023472-000

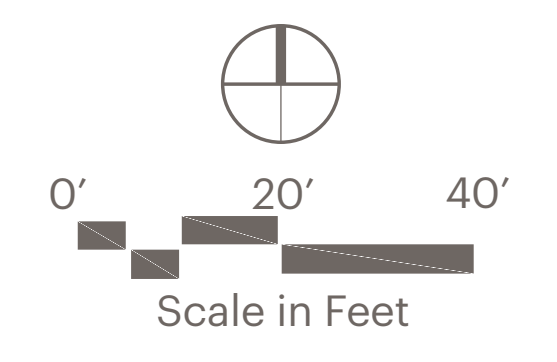

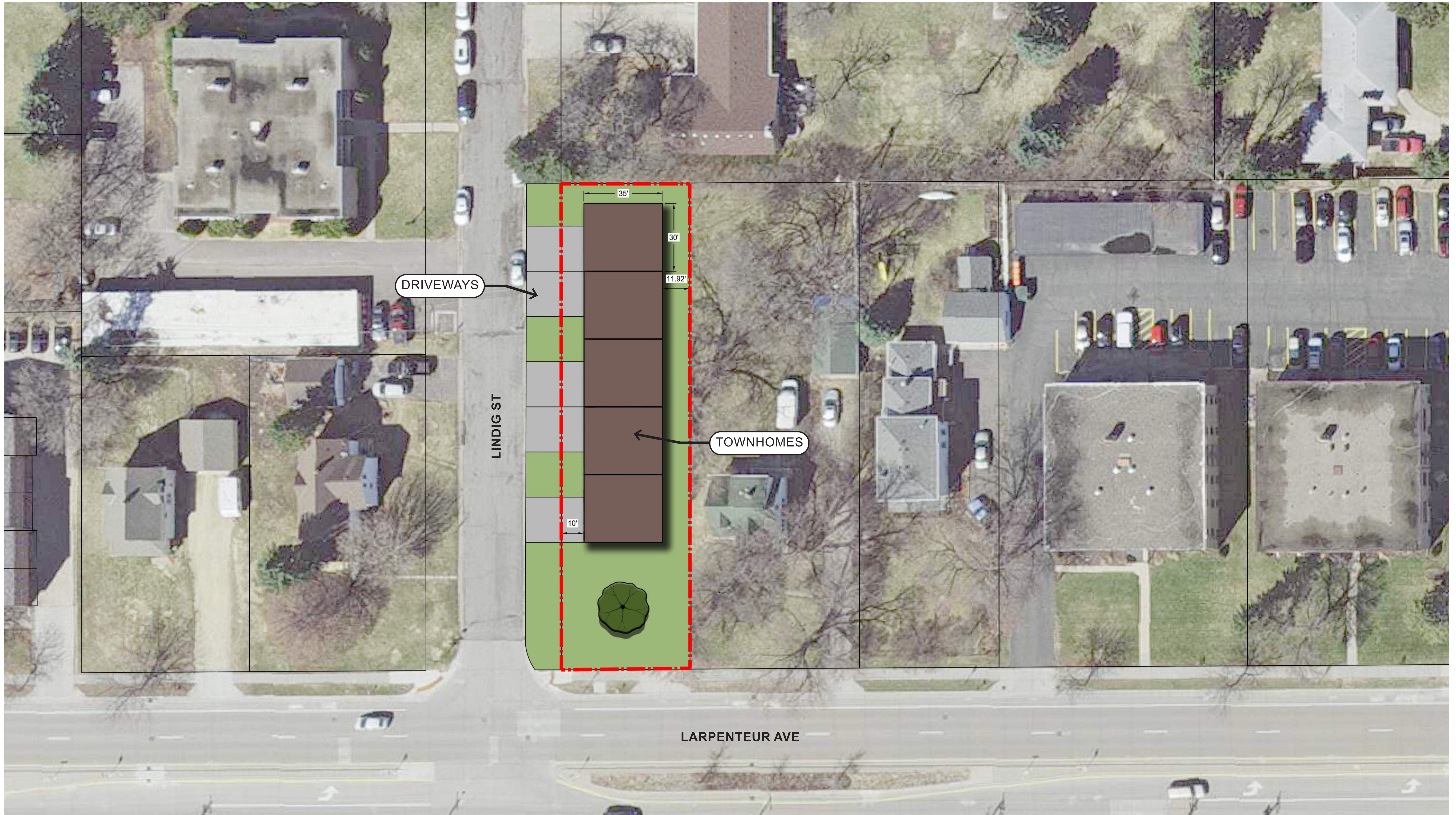

K:\023472-000\Graphics\Concepts\023472-000 Snelling Larpenteur Corridor Study

Snelling Larpenteur Corridor Study | Area 2: Option B

Falcon Heights, MN
June 4, 2024 | WSB Project number: 023472-000

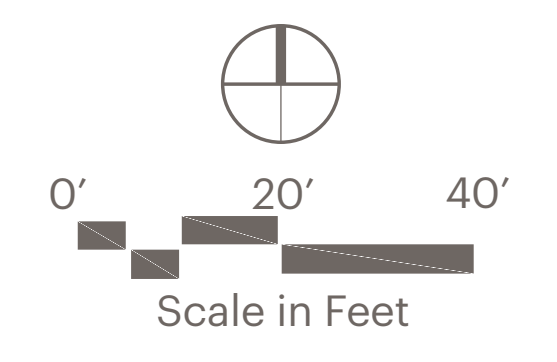

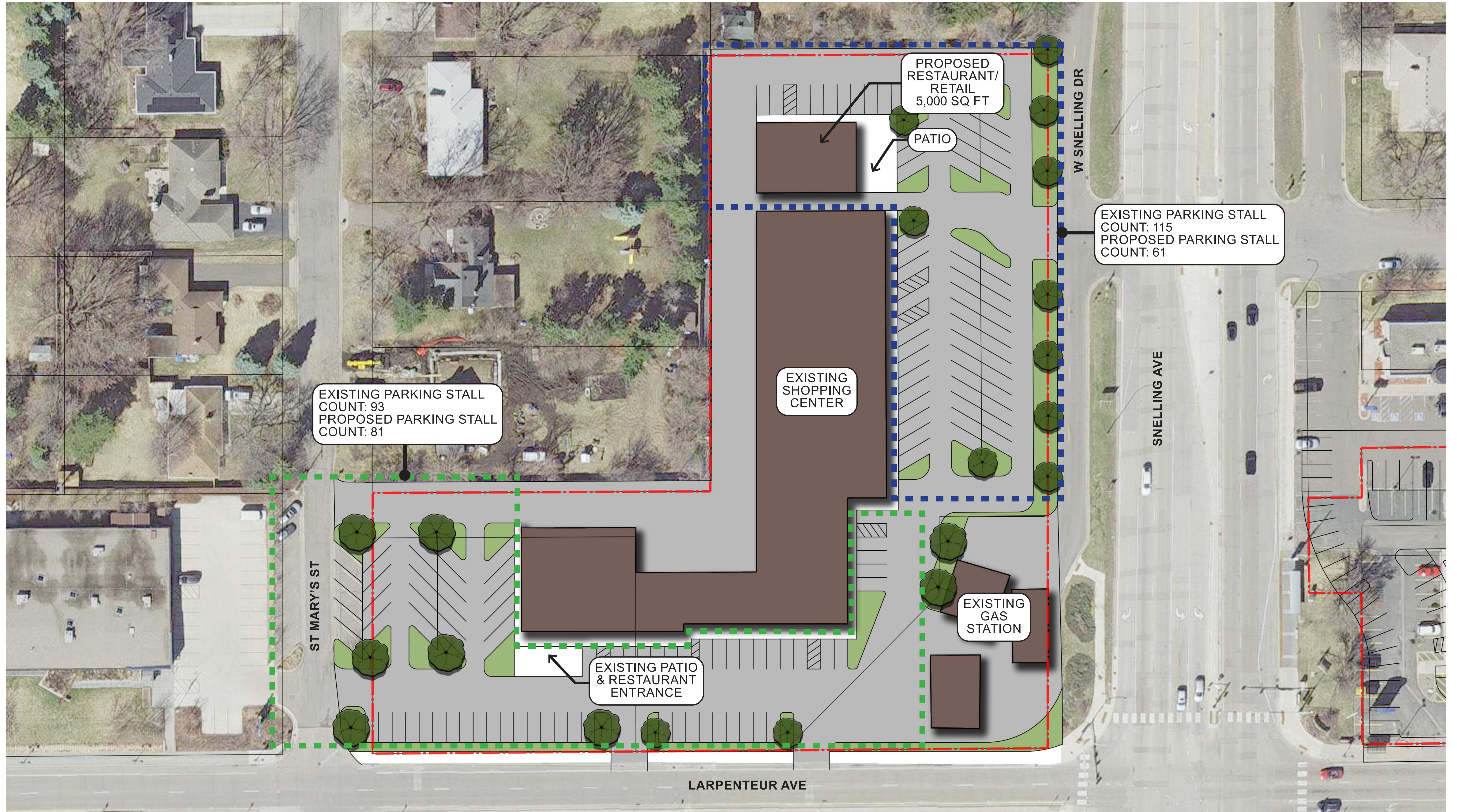

Snelling Larpenteur Corridor Study | Area 3

Falcon Heights, MN

June 4, 2024 | WSB Project number: 023472-000

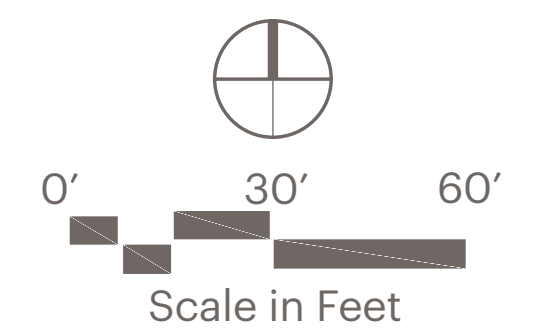



K:\023472-000\Graphics\Concepts\023472-000 Snelling Larpenteur Corridor Study

Snelling Larpenteur Corridor Study | Area 4: Option A

Falcon Heights, MN
June 4, 2024 | WSB Project number: 023472-000

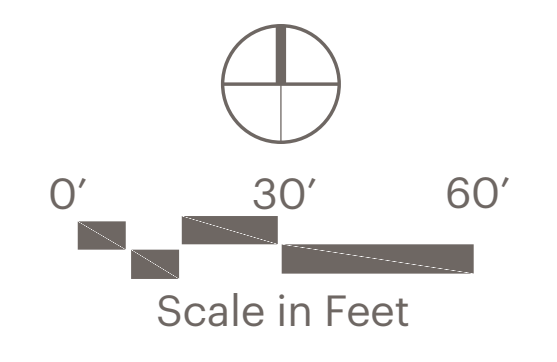



K:\023472-000\Graphics\Concepts\023472-000 Snelling Larpenteur Corridor Study

Snelling Larpenteur Corridor Study | Area 4: Option B

Falcon Heights, MN

June 4, 2024 | WSB Project number: 023472-000

