

City of Falcon Heights Environment Commission

City Hall
2077 Larpenteur Avenue West

AGENDA

Monday, December 9, 2024
6:30 p.m.

A. CALL TO ORDER: 6:30 p.m.

B. ROLL CALL: Beth Mercer-Taylor (Chair) ____ Jared Mehlhaff ____
John Pellegrini (Vice-Chair) ____ Amy Christiansen ____
Adam Keester ____ Sophie Nagel ____
Pedro De Filippo Vannucci ____

Staff Liaison Lynch ____
Council Liaison Mielke ____

C. APPROVAL OF AGENDA

D. APPROVAL OF MINUTES

1. October 14, 2024

E. NEW BUSINESS

1. Tree Trust Information - Karen Zumach
2. Undergraduate Leadership Program Students - Project Presentation
3. Plastic Bag Recycling
4. Sustainability Fair

F. INFORMATION AND ANNOUNCEMENTS

1. Staff Liaison Report
2. Council Liaison Report

G. ADJOURN

Next regular meeting date: January 13, 2025

City of Falcon Heights Environment Commission

City Hall
2077 Larpenteur Avenue West

Minutes

Monday, October 14, 2024
6:30 p.m.

A. CALL TO ORDER: 6:30 p.m.

B. ROLL CALL:

Beth Mercer-Taylor (Chair)	<input checked="" type="checkbox"/>	VACANT	<input type="checkbox"/>
John Pellegrini (Vice-Chair)	<input checked="" type="checkbox"/>	Amy Christiansen	<input type="checkbox"/>
Jared Mehlhaff	<input type="checkbox"/>	Adam Keester	<input checked="" type="checkbox"/>
Pedro De Filippo Vannucci	<input checked="" type="checkbox"/>		
Staff Liaison Lynch	<input checked="" type="checkbox"/>		
Council Liaison Mielke	<input checked="" type="checkbox"/>		
GreenCorps Member Siebert	<input checked="" type="checkbox"/>		

C. APPROVAL OF AGENDA

Staff Liaison Lynch suggested one change to the agenda. She suggested changing item E1 to a tree survey updated from GreenCorps Member Olivia Siebert. Karen Zumach from the Tree Trust is unable to attend. Chair Mercer-Taylor made a motion to approve the agenda with the suggested amendment. Agenda was approved with amendment by consent.

D. APPROVAL OF MINUTES

1. June 10, 2024

2. September 9, 2024

Chair Mercer-Taylor made a motion to approve minutes from June 10, 2024 and September 9, 2024. Minutes were approved by consent.

E. NEW BUSINESS

1. Tree Survey Update – GreenCorps Member Olivia Siebert

GreenCorps Member Olivia Siebert explained she has been walking/biking throughout the City to map all boulevard trees and potential spaces for these. She showed an example block of the City for Commissioners to see the work she is doing. Staff Liaison Lynch explained the goal is to have all of these mapped so we can keep track of what is being added/removed and so the City can equitably determine where to replace/add new trees for residents. GreenCorps Member Siebert explained the previous survey was done before

the ash trees were removed and the data has changed a lot since then without having been updated.

2. **Partners in Energy Update**

Staff Liaison Lynch updated Commissioners on the status of the Energy Action Plan. She explained it went through another revision to change wording as requested by Council Member Eric Meyer. She let Commissioners know it would be going to City Council for adoption on October 23, and assuming it is adopted then, would be kicked off at the Fall Fest event being held by the City on October 26.

3. **Climate Action Plan Introduction**

GreenCorps Member Siebert handed out QR codes to Commissioners leading to the Climate Action Plan survey and Climate Action Plan team member application. Staff Liaison Lynch requested Commissioners take the survey and pass QR codes out to neighbors and other residents. She explained many survey responses are needed and the City also needs a very diverse group of people for the team. She stated Commissioners are not required to be on the team, but are welcome to. Team members will be expected to attend 4-6 events of 1-4 hours long, and the Plan needs to be completed by the end of July.

F. **Information and Announcements**

1. **Staff Liaison Report**

Staff Liaison Lynch reminded Commissioners of the Falcon Heights Fall Fest on October 26. She explained the Energy Action Plan, assuming it is adopted by City Council on October 23, would be kicked off at this event. She also updated Commissioners on the Solar for Public Buildings grant opportunity. She explained the City will be applying for this with the hope of removing and recycling the existing panels on City Hall and installing a new array.

2. **Council Liaison Report**

Council Liaison Mielke also reminded Commissioners of the Fall Fest and the 75th Anniversary event that would be held just before the event on the same day. She also told them about 75th Anniversary Trivia to be held at Stout's on October 29, 2024. She updated Commissioners on the Monarch Joint Venture's monarch-tagging event that was held at Community Park recently. Finally, she gave an update on the Community Park building status and asked that the Commissioners comment on the types of plants that are added at Community Park towards the end of the upcoming construction.

G. **Adjourn**

Meeting was adjourned at 7:57 p.m.

Next regular meeting date: December 9, 2024



ITEM FOR DISCUSSION

Meeting Date	December 9, 2024
Agenda Item	E-1
Attachment	None.
Submitted By	Hannah Lynch, Community Development Coordinator / Planner

Item	Tree Trust Information
Description	Karen Zumach is here to present information on the Tree Trust and how Falcon Heights could potentially get involved with a tree sale, boulevard trees, volunteers, etc.
Budget Impact	None.
Attachment(s)	None.
Action(s) Requested	Staff requests Environment Commission discuss potential partnerships with Tree Trust for tree sale and/or boulevard trees.



ITEM FOR DISCUSSION

Meeting Date	December 9, 2024
Agenda Item	E-2
Attachment	None.
Submitted By	Beth Mercer-Taylor, Environment Commission Chair

Item	Undergraduate Leadership Program – Project Presentation
Description	A team of four University of Minnesota students, enrolled in the Undergraduate Leadership Program (run by the Institute on the Environment), are working on a project around the future of the golf course property that involve themes of affordable housing, low-cost and sustainable energy sources, and preservation of recreational green spaces. While no immediate sale of the golf course property is planned, the idea is to seed ideas for the future.
Budget Impact	None.
Attachment(s)	<ul style="list-style-type: none"> • Future Golf Course Development Presentation
Action(s) Requested	Staff requests Environment Commission discuss presentation by UofM students and provide feedback.

FUTURE GOLF COURSE DEVELOPMENT

Presented by: Falcon Heights Energy &
Equity IonE Group



OUR TEAM

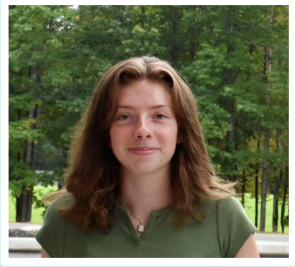

Megan Cunningham
Junior Urban Studies
Major

Madison Cocker
Senior Biochemistry +
English Double Major

Janelle Barlan
Freshman ESPM
Enviro. Science Major

Ethan Cederberg
Junior Environmental
Engineering Major

GOALS

01

Sustainability

Low cost, sustainable energy sources.

02

Affordability

Affordable, low-income housing.

03

Recreation

Green spaces that can be used for recreation.

04

Our Plan

Steps that we will take and our end goal.



ECO/ ENERGY EFFICIENT/ PASSIVE HOUSING

- Just Housing is a company based in Duluth that presented to the Twin Ports Climate Conversation that many of our group members were present at. They focus on making replicable and scalable homes that do not use any fossil fuels (they are all electric)
 - Ready-to-build plans for single-family and two-family homes, widely applicable, geared towards colder climates (urban and rural)
- Is there a preference for single/double family homes versus apartment communities?
 - Single-family prefabricated homes - plans available from IdeaBox building and GoHome by GoLogic that combine efficiency with a variety of options for families and can be assembled in two weeks.
- Les Bolstad golf course has ample developable land that can be used for multi-family housing, addressing the ongoing affordable housing crisis

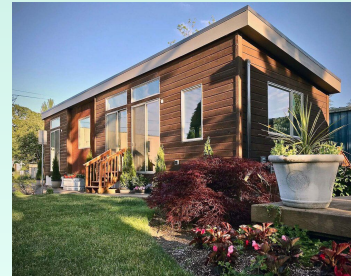

SUSTAINABLE ENERGY

- Work with UMN architecture library to see if the golf course is a candidate for geothermal energy
- Utilize photo-voltaic (PV) solar and active solar heating
- Use geothermal or active solar as heat sources for heat pumps
 - Heat pumps connected to district energy system to cool/heat buildings
 - Possible implementation of absorption refrigeration to lower electricity usage

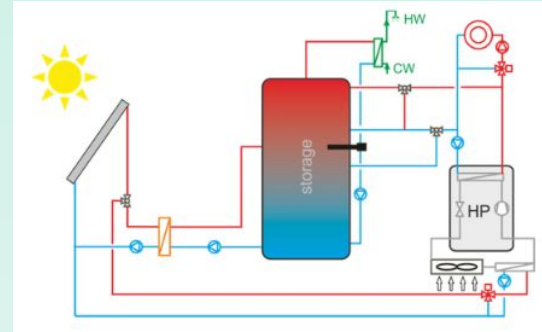

Figure showing heat pump with solar integrated into refrigerant cycle (Lerch, 2015)

RECREATIONAL GREEN SPACE

- Residents want a park area?
 - Recreation, green space, community areas
- Community gardens
 - SE corner of Roselawn & Cleveland
 - Operate with same rules as current garden
- Pollinator friendly gardens, rain gardens?
 - Emphasis on native flowering plants
- Include connecting paths/trails
 - Currently: turfgrass
- Green spaces may be woven in with solar farm as space between and under solar panels
- Playground/more structured space?



OUR PLAN

- Ecodistrict Equity Plan: Develop both written and visual plans that the City of Falcon Heights can use to guide the development of the Les Bolstad Golf Course or future large scale development projects
 - Collect and use community input to guide the plan (door-knocking and surveying)
 - Helping Falcon Heights residents understand the changes that **can** be made
 - GIS maps of potential development plans
- Investigate zoning issues/rezoning - currently zoned P-1 (public land) and would need to be rezoned if used for single or multi-family housing

THANK YOU!

Feel free to ask any questions or provide
any feedback/concerns!





ITEM FOR DISCUSSION

Meeting Date	December 9, 2024
Agenda Item	E-3
Attachment	See below.
Submitted By	Olivia Siebert, GreenCorps member

Item	Plastic bag/plastic film recycling
Description	<p>Falcon Heights residents have expressed interest in plastic film recycling. Merrick, Inc is a local company in Vadnais Heights that offers plastic film recycling and empowers adults with disabilities through vocational opportunities. They offer pick up (\$36 per load) and drop off (\$10 per load) services and accept many hard-to-recycle products. From the Merrick, Inc website:</p> <p>Accepted Materials</p> <ul style="list-style-type: none"> • Pallet wrap & stretch film • Case overwrap • Product wrap • Garbage bags/liners • Toilet paper/paper towel/water bottle wrapping • Salt bags • Ice bags • Non-paper bubble mailers & other plastic mailers • Grocery/retail bags • Ziploc & other re-sealable food storage bags • Bread bags • Cereal/pasta bags • Dry cleaning bags • Newspaper sleeves • Produce bags • Carpet overwrap • Furniture foam wrap • Heat sheets • Mattress bags • Wood pellet bags • Bubble wrap • Soft flexible foam

	<p>Unaccepted Materials</p> <p>We do not accept the following materials:</p> <ul style="list-style-type: none"> • Wet material • Hard plastic (e.g. water bottles) • Pallet strapping • Freight/shipping air sacs • Material containing nylon (sometimes looks like a grid in the plastic – common in pet food bags & freight/shipping air sacs) • Biodegradable/compostable bags or film packaging • Adhesives • Sticker backing • Organic material (including paper & cardboard) • Frozen food bags • Pre-washed salad mix bags • Six-pack rings • Aluminum-lined &/or metallic-looking packaging (ex. Chip bags & candy bar wrappers) • Rubber • Metal
Budget Impact	None.
Attachment(s)	None.
Action(s) Requested	Staff requests Environment Commission discuss offering plastic bag recycling drop-off services at City Hall.



ITEM FOR DISCUSSION

Meeting Date	December 9, 2024
Agenda Item	E-4
Attachment	See below.
Submitted By	Olivia Siebert, GreenCorps Member

Item	Sustainability Fair 2025
Description	The Environment Commission has previously hosted sustainability fairs in partnership with St Anthony Village. They offer opportunities for residents to learn about new technologies and get involved with sustainable causes. In the past, they have included speakers, tabling, events, and demonstrations. The proposed fair could include any of those events as well as a textile shredding/recycling service.
Budget Impact	None.
Attachment(s)	<ul style="list-style-type: none"> • Sustainability Fair Commission Handout
Action(s) Requested	Staff requests Environment Commission discuss themes for this year's fair, offer ideas for events, and suggest potential partner organizations.

Sustainability Fair 2025 Commission handout

Previous ideas from 2018/2019:

Topics:

- Stormwater management
- EVs
- Native planting/pollinator planting
- Zero waste and composting
- Home energy efficiency
- Renewable energy

Partner orgs/ suggested orgs:

- Capitol Region Watershed District
- Fresh Energy
- Ramsey Co Environmental Health
- Center for Energy and Environment/Partners in Energy
- Citizens Utility Board
- RCHS/Gibbs farm
- Clean Energy Resource Teams (CERTs)
- Midwest renewable energy association
- St Anthony Village – Citizens for Sustainability
- Tennis/Eureka
- Do it Green MN
- Bee Lab
- Ramsey Co recycling ambassadors
- EV association
- Home Energy Squad
- Dept of Commerce
- State Fair Eco Experience

Events/activities

- Give away LEDs and ask people to pledge to replace all lightbulbs with LEDs
- Tabling from different organizations
- Speakers

2025 ideas:

- Free compost buckets (recycled Terracycle bin, \$18/bin for 51+)
- Free Home Energy Squad visit drawing
- Bingo
- Pollinator mix seeds (\$0.75 per packet)
- Shredding / Textile Recycling event