

Mayor:
Lee Hunt
Councilmembers:
Steve DeLapp
Susan Dunn
Dean Johnston
Wyn John

Lake Elmo City Council

Tuesday September 7, 2004

3800 Laverne Avenue No.
Lake Elmo, MN 55042
777-5510 777-9615 (fax)

Please read:

Since the City Council does not have time to discuss every point presented, it may appear that decisions are preconceived. However, staff provides background information to the City Council on each agenda item in advance; and decisions are based on this information and experience. In addition, some items may have been discussed at previous council meetings.

If you are aware of information that has not been discussed, please fill out a "Request to Appear Before the City Council" form; or, if you came late, raise your hand to be recognized. Comments that are pertinent are appreciated. Items may be continued to a future meeting if additional time is needed before a decision can be made.

Agenda

City Council Meeting Convenes 7:00 PM

Pledge of Allegiance

1. Agenda

2. Minutes

August 17, 2004

3. PUBLIC INQUIRIES/INFORMATIONAL:

A. PUBLIC INQUIRIES:

**B. Kathi Pelnar: Animal Control Officer:
Ordinance Relating to Confinement of Dogs**

Public Inquiries/Informational is an opportunity for citizens to bring the Council's attention any items not currently on the agenda. In addressing the Council, please state your name and address for the record, and a brief summary of the specific item being addressed to the Council. To allow adequate time for each person wishing to address the Council, we ask that individuals limit their comments to three (3) minutes. Written documents may be distributed to the Council prior to the meeting or as bench copies, to allow a more timely presentation.

4. CONSENT AGENDA

A. Planning Commission Resignations

B. Resolution No. 2004-074: Approve claims

C. Resolution No. 2004-078: Partial Payment No. 4 to Schifsky & Sons for Hill Trail N./50th Street

Those items listed under the Consent Calendar are considered to be routine by the City Council and will be enacted by one motion under a Consent Calendar format. There will be no separate discussion of these items unless a Council member so requests, in which event, the item will be removed from the general order of business and considered separately in its normal sequence on the agenda.

5. FINANCE:

A. Resolution No. 2004-075: Adopting Levy Limit

B. Resolution No. 2004-076: Set Truth n' Taxation Hearing Dates

6. NEW BUSINESS

<p>7. <u>MAINTENANCE/PARK/FIRE/BUILDING:</u> A.</p>		
<p>8. <u>CITY ENGINEER'S REPORT:</u> A. Hill Trail Assessment Appeal, Resolution No 2004-069: Adopting Hill Trail/50th Street Assessments B. Highlands Trail Speed Study Results C. 45th Street Pond</p>	<p>Tom Prew</p>	
<p>9. <u>PLANNING, LAND USE & ZONING:</u> A. Zoning Ordinance Amendment -Family Entertainment Center:CUP in GB Zone B. Amendments to Section 150 - Building Height</p>	<p>C. Dillerud</p>	
<p>10. <u>CITY ATTORNEY'S REPORT:</u></p>		
<p>11. <u>CITY ADMINISTRATOR'S REPORT:</u> A. Set Public Works Council Committee Meeting Date (Verbal)</p>		
<p>12. <u>CITY COUNCIL REPORTS:</u> A. Mayor Hunt B. Council Member DeLapp C. Council Member Dunn D. Council Member Johnston E. Council Member John</p>		
<p>CLOSED MEETING: September 7, 2004, 8:00 p.m.; Discuss Legal Options with the City's Met Council Attorney</p>	<p>Environmental Meeting: September 15, 2004 7:00 p.m.</p>	



City of Lake Elmo

651/777-5510

3800 Laverne Avenue North / Lake Elmo, MN 55042

**THE LAKE ELMO CITY COUNCIL
WILL HOLD A CLOSED MEETING
TO DISCUSS LEGAL OPTIONS WITH THE
CITY'S MET COUNCIL ATTORNEY**

**TUESDAY, SEPTEMBER 7, 2004
8:00 P.M. (After the City Council Meeting)**

**LAKE ELMO CITY HALL
3800 LAVERNE AVENUE NORTH
LAKE ELMO, MINNESOTA**

LAKE ELMO CITY COUNCIL MINUTES

AUGUST 17, 2004

1. AGENDA
2. MINUTES: August 4, 2004
3. PUBLIC INQUIRIES/INFORMATIONAL:
4. CONSENT AGENDA:
 - A. Resolution No. 2004-068: Approve Claims
 - B. Reschedule November 2, Council Meeting
 - C. Resolution No. 2004-072 Approve Additional Claim
5. FINANCE:
 - A. INFORMATIONAL: Date Change for Public hearing on Bond Resolution August 31, 2004
 - B. INFORMATIONAL: Monthly Operating Report
6. NEW BUSINESS:
7. MAINTENANCE/PARK/FIRE/BUILDING:
 - A. Update on Building Dept. Activities: Jim McNamara
 - B. Fire Sprinklers – Prairie Ridge Office Park
8. CITY ENGINEER'S REPORT:
 - A. PUBLIC HEARING: Assessment for Hill Trail N./50th Street:Resolution No. 2004-069
 - B. PUBLIC HEARING: Assessment for 2004 Overlay Project; Resolution No. 2004-070
 - C. Proposed 4-Way Stop Highlands Trail/59th Street
 - D. VFW Ball Field Lights
9. PLANNING, LAND USE & ZONING:
 - A. Open Space Concept Plan:Tapestry at Charlotte's Grove:Resolution No. 2004-071
10. CITY ATTORNEY'S REPORT:
11. CITY ADMINISTRATOR'S REPORT:
 - A. Highway 5
 - B. Fire Service Agreement with City of Hudson, WI
 - C. Disposal of Fire Equipment
 - D. Animal Ordinance Amendment
 - E. Purchase offer for 3585 Laverne Avenue
 - F. Vacation of 55th Street
 - G. Council Committees
12. CITY COUNCIL REPORTS:
 - A. Mayor Hunt: Board of Directors Vacancies; LMC 2004 Annual Conference
 - B. Council Member John:Discussion of Smoking Ban

Mayor Hunt called the meeting to order at 7:00 p.m. in the Council Chambers.
PRESENT: John, Dunn, Hunt, Johnston, DeLapp, City Engineer Prew, City Attorney Filla, Building Official McNamara, Finance Director Tom Bouthilet, and Administrator Rafferty.

1. AGENDA

Add: Refer Vacation of 55th Street to Planning Commission, New City Center, Council Committees

M/S/P Dunn/Johnston - to approve the August 17, 2004 City Council agenda, as amended. (Motion passed 5-0).

2. MINUTES: August 4, 2004

M/S/P DeLapp/Johnston - to approve the August 4, 2004 City Council Minutes, as amended. (Motion passed 4-0-1:Abstain Hunt).

3. PUBLIC INQUIRIES/INFORMATIONAL:

Frank Orsello, Oakdale Lake Elmo Historical Society President, thanked the Council for the \$1,000 donation. He presented a budget proposal to the city for office supplies that would cost approximately \$75 to \$100 a month.

M/S.P Dunn/John - to remit the request to city staff for discussion based on money available in the budget. (Motion passed 5-0.)

4. CONSENT AGENDA:

A. Resolution No. 2004-068: Approve Claims

M/S/P DeLapp/Johnston - to adopt Resolution No. 2004-068, approving claim numbers 211 212, DD211 through DD229 25898 through 26021, that were used for staff payroll dated August 5, 2004, Claim Numbers 26022 through 26059 dated August 17, 2004 in the total amount of \$77,595.27. (Motion passed 5-0).

B. Reschedule November 2, Council Meeting

M/S/P DeLapp/Johnson - to reschedule the November 2, 2004 City Council meeting to Wednesday, November 3, 2004 because of the General Election held on this date. (Motion passed 5-0).

C. Resolution No. 2004-072 Approve Additional Claim

M/S/P DeLapp/Johnston - to adopt Resolution No. 2004-072, approving claim number 26060 payable to the City of Oakdale dated August 17, 2004 in the total amount of \$12,871.48. (Motion passed 5-0.)

5. FINANCE:

A. INFORMATIONAL: Date Change for Public Hearing on Bond Resolution

The Public Hearing on the Bond Resolution will be held on Tuesday, August 31, 2004, 7 p.m. at City Hall. This meeting will be cabled. The Budget Workshop will be held after the hearing.

M/S/P DeLapp/Johnston – to send the notice to the people, determined by staff, that would be affected by the city center proposal in the Lions Park area and include a sketch. (Motion passed 5-0.)

B. INFORMATIONAL: Monthly Operating Report

Finance Director Bouthilet provided a monthly operating report and reported the budget was on-track.

6. NEW BUSINESS:

7. MAINTENANCE/PARK/FIRE/BUILDING:

A. Update on Building Dept. Activities: Jim McNamara

The Building Official reported that in the month of July there were two new residential permits issued and two new commercial permits issued. He reminded residents that contractors should be state licensed to complete a roof project and permits for fences are now required.

B. Fire Sprinklers – Prairie Ridge Office Park

The City Planner reported in his memo that as a part of the Council's approval action on the site plan for the Prairie Ridge office condos (Highway 5 at Stillwater Blvd.) it is agreed that the developer would be required to only install "dry" fire sprinkler systems. That concession by the City was based on the inability of the City to extend municipal water service to the site in a financially feasible manner due to Oakdale water supply contract issues.

The City has been contacted by the developer advising that the State Fire Marshall will not permit installation of "dry" sprinkler systems due to the false sense of security such installations will project. The Building Official explained since we are not able to service water, the state was very reluctant to approve other than a full live system. A letter was signed by the Building Official and Fire Chief indicating they wave the requirement of the fire sprinkler systems for the Prairie Ridge development due to the fact that the city does not have the ability to furnish the development with the necessary water supply for a fire sprinkler system. This option is given under Section 1306.0060 of the fire sprinkler code providing other requirements are met.

The Council asked that the Planning Commission be made aware of these items when it looks at the impact on the Limited Business area where there is no water.

M/S/P Johnston/John -- to approve an amendment to the site plan approval of Prairie Ridge Office Park deleting the condition requiring the installation of a "dry" fire sprinkler system in its entirety based on the recommendation received from the City Planner and the waiver letter dated August 11, 2004 from the Building Official and Fire Chief. (Motion passed 4-1:DeLapp stated there is no reason why this decision premise of the ordinance especially when there is water available.)

8. CITY ENGINEER'S REPORT:

A. PUBLIC HEARING: Assessment for Hill Trail N./50th Street:Resolution No. 2004-069

The City Engineer reported the project is nearly complete and only turf establishment work remains. He recommended adoption of the assessment rate of \$2,500.00 per unit (67.5 assessable units) for this project.

Roger Johnson, 8048 Hill Trail N., submitted a notice of objections indicating two of his parcels were combined as a condition of his purchase of a parcel last spring. He has provided Washington County the proper paperwork to combine the parcels, but the County has not completed the consolidation.

Bud Talcott, 8051 Hill Trail N., provided a memo, dated August 17, 2004, of concerns raised with the project.

The City Engineer said that he would meet with the City Attorney to discuss the validity of these concerns and objections.

Mayor Hunt opened up the Public Hearing in the Council Chambers at 7:40 p.m. Council member Johnston objected to the discussed changes in the assessment policy because the City has a well defined assessment policy which has been consistently administered and any objections are satisfied. Mayor Hunt closed the Public Hearing at 7:42 p.m.

Attorney Filla advised that the Council could postpone adoption or adopt the assessment roll with the exception of the two parcels in question.

M/S/P Hunt/DeLapp -- to postpone consideration of adopting assessments for the reconstruction of Hill Trail N. and 50th Street N. until the September 7th meeting for resolution of the requests by Roger Johnson and Bud Talcott by the City Engineer. (Motion passed 5-0).

B. PUBLIC HEARING: Assessment for 2004 Overlay Project; Resolution No. 2004-070

The City Engineer reported the project is complete and recommends adoption of the assessment rate of \$1,222.00 per unit (21 assessable units) for this project.

Mayor Hunt opened up the Public Hearing at 7:50 p.m. in the Council Chambers
There was no one to speak for or against the assessments.
Mayor Hunt closed the Public Hearing at 7:51 p.m.

M/S/P DeLapp/Johnston – to adopt Resolution No. 2004-070, A Resolution Adopting Assessments for the 2004 Overlay Projected as presented by the City Engineer. (Motion passed 5-0).

C. Proposed 4-Way Stop Highlands Trail/59th Street

The Public Works Council Committee recommended a 4-way stop condition be placed at the intersection of Highlands Trail and 59th Street. In his letter dated August 12th, Tom Prew recommended not to install a 4-way stop as it was not warranted. The recommendation for a 4-way stop condition stems from the neighborhood request for traffic calming. In his opinion, a nuance stop sign at this location would have very little effect on the overall speed of traffic on Highlands Trail. Making physical changes to the street is the best method to reduce vehicle speed. Prew recommended performing a speed study to determine the scope of the speeding problem.

M/S/P DeLapp/John – to direct the City Engineer to come back with a speed study to determine the scope of the speeding problem on Highlands Trail. (Motion passed 5-0).

D. VFW Ball Field Lights

The City Planner reported the installations of the new lights have been recently completed. A verbal agreement several months ago with an adjacent property owner to provide the city with an easement to run the new power supply unraveled once Xcel presented the actual plan as to where the new power lines/poles would be located on that adjacent property owners land. Several alternative concepts were also presented to the property owners, but none of which could be accommodated. It was finally decided to route the power from a different location and within the Layton Avenue right-of-way, with increased costs the result.

The previous Xcel contract price to bring the power to the ball field was \$9,994.57. The new revised route down Layton Avenue results in an Xcel cost of \$12,205.37 and an increase in the project cost of \$2,210.80.

M/S/P DeLapp/Johnston – to approve an increase in the cost of the VFW ball field lights project by \$2,210.57 to accommodate a revised routing for the required Xcel power supply. (Motion passed 5-0).

9. PLANNING, LAND USE & ZONING:

A. Open Space Concept Plan: Tapestry at Charlotte's Grove: Resolution No. 2004-071

Senn & Youngdahl are proposing 67 single family homes on 172 acres located east of Lake Jane along 45th Street and west of Hamlet on Sunfish Lake. The City Planner reported that the OP Concept Plan for Tapestry at Charlotte's Grove (staff dated August 5) both mitigated most of the former OP standards compliance issues, and also addressed many of the issues raised at the Planning Commission's public hearing. The primary remaining OP standards non-compliance issue (proposed to be a 4/5 Council OP variance) is the proposed encroachment of a public street into the 200 foot OP buffer along a short portion of the project's west border. The Commission discussed this encroachment at length and offered the Council a recommendation to approve the variance responsive to the purposes and intent of the OP ordinance. There will be a right turn lane to address the safety concern with exiting 45th Street. Connection to the city's trail system is also being planned.

Council member Dunn voiced her concern about flooding from Sunfish Lake and made the developer aware of VBWD letter and the affect on wetlands.

M/S/P DeLapp/Johnston - to adopt Resolution No. 2004-071 approving the OP Concept Plan for Tapestry at Charlotte's Grove based on the plans staff dated August 5, 2004 and the Findings/Recommendation of the Planning Commission. (Motion passed 5-0)

M/S/P DeLapp/Johnston - further, that the Council endorses the concept of a minor public street encroachment into the OP buffer as depicted by the August 5th Plan as a 4/5 OP variance in the future OP Development Stage Plan. (Motion passed 5-0).

10 CITY ATTORNEY'S REPORT: None

11. CITY ADMINISTRATOR'S REPORT:

A. Highway 5

The City Administrator reported him, the City Planner and City Engineer met with engineering representatives of Washington County Engineering and the Minnesota Department of Transportation. The following items were discussed.

1. Long term planning, construction implementation and ownership of Hwy 5.
2. Safety issues to be addressed with short term planned maintenance activities, subject to funding.
3. And the development of alternate traffic routing and shared funding plans in the future.

MnDot discussed the Mill/Overlay project scheduled for September 2004, and no possibility (funding) for changes at this time. They also identified other maintenance and safety related upgrades scheduled for the future; pending funding. Tom Prew is working on a proposal to do a bypass study. The City Administrator noted that residents raised traffic issues on the west end, and there will be continued vigilance on speeding by the sheriff's dept. Council member Dunn asked to put on website and cable when the mill overlay project will be started.

B. Mutual Aid for St. Croix Valley and Hudson Fire Station

The Council was provided an agreement for the Lake Elmo Fire Department to provide Mutual Aid to the St. Croix Valley and Hudson Fire Departments. This agreement is key to the area wide response to emergency situations and has been reviewed and recommended for approval by the City Attorney, the Fire Chief and the City Administrator.

M/S/P DeLapp/Johnston – to approve the Mayor, City Administrator, and Fire Chief sign the Mutual Aid Agreement with St. Croix Valley and Hudson Fire Service. (Motion passed 5-0).

C. Disposal of Fire Equipment

M/S/P Dunn/DeLapp – to approve the Mayor, City Administrator and Fire Chief sign an agreement to transfer outdated surplus Air Pack equipment to receiving city. (Motion passed 5-0).

D. Animal Ordinance Amendment

The Community Improvement Committee has studied the current ordinance regulating restraining of dogs. The CIC has recommended that a minor change to the dog ordinance be adopted. The change proposed requires that a dog owner employ an active restraint system if the dog is left outside and the owners are not home.

Rod Sessing and Council member DeLapp questioned the relevancy of the property owner being home or not and why penalize them for when the owner is not home. Council member Johnston stated that his interpretation of the opinion of animal control is that invisible fencing was not efficiently effective and additional protection was a good policy. Ann Smith, Vice Chair of the CIC, stated if the dogs stay in the invisible fence, the property owner will not get fined. This would protect people in the future when the owner is not home all day long. Joan Ziertman, CIC member, stated she would rather see extra enforcement when a person is gone a long time. Council member Dunn said she wasn't convinced that invisible fences were causing a problem in the city and was not prepared to make a change to the dog ordinance.

Animal Control Officer Kathi Pelnar provided a year end report listing the number of dogs picked up wearing invisible fence collars. For both 2003 and 2004 that number was four dogs. The Council wanted to talk with the ACO to try to understand the actual magnitude of the problem.

M/S/P Johnston/ Dunn – to invite Kathie Pelnar, ACO, to come to the September 7th Council meeting to discuss animal control under the Public Information section of the meeting agenda. (Motion passed 5-0).

E. Purchase offer for 3585 Laverne Avenue

Council member Johnston stated he was in favor of a city center and buying this property in question because it s contiguous to the Lions Ball Field. He suggested inviting residents that would be affected by a proposed new city center to a public hearing. The City Administrator added the City is looking at alternative locations for the Lake Elmo Library and this property could serve that purpose until a city center has been decided.

M/S/P Johnston/John - to authorize the Mayor to sign the purchase agreement for the property located at 3585 Laverne Avenue, Lake Elmo, Minnesota; and acknowledgments of receipt of disclosure of sewage treatment system, supplemental disclosure regarding individual On-Site System and Seller Property Disclosure Statement. (Motion passed 5-0.)

F. Vacation of 55th Street

M/S/P Johnston/Dunn – to send this item to the Planning Commission for study and review based on the recommendation of the Public Works Council Committee. (Motion passed 5-0.)

G. Council Committees

Attorney Filla provided a draft resolution defining the duties of the three established City Council Committees.

M/S/P John/Dunn – to adopt resolution No. 2004-074, A Resolution Relating to Council Committees (Motion passed 5-0.)

12. CITY COUNCIL REPORTS:

A. Mayor Hunt: Board of Directors Vacancies; LMC 2004 Annual Conference

Mayor Hunt explained it would be a fantastic opportunity to have a booth at the conference to contact other cities at the LMC 2004 Conference held in Duluth. Council member DeLapp added that we need information, such as, MN Design Team information, pictures of developments and the proposed city center, to attract their interest.

Mayor Hunt and Council members Dun, DeLapp and Johnston indicated they would be attending the LMC Conference.

M/S/P Johnston/John – to authorize \$700 to reserve a booth at the LMC conference. (Motion passed 5-0.)

Board of Directors Vacancies:

At the Annual Meeting in Duluth on October 11th, the membership will elect four new members to the Board of Directors. Council member Johnston indicated he would be interested in the nomination, but pulled his name out of consideration when Mayor Hunt indicated he would also be interested.

M/S/P DeLapp/Dunn – to submit Lee Hunt's name for nomination to serve on the LMC Board of Directors. (Motion passed 5-0).

Council member Dunn attended the VBWD meeting to listen to the discussion regarding a proposal for a market place and super target on 70 acres along highway 5 bordering Oakdale and Lake Elmo. Dunn said resident, Debbie Dean, asked excellent questions on water quality and runoff and how it relates to more traffic on Highway 5. The proposal was passed by the VBWD.

Council member Johnston said he was the last customer at the pancake breakfast held by the Fire Department. Dean asked about the status of the City's diseased tree program. The Administrator responded this item will be placed on the Public Works Council Committee agenda. Council member John suggested looking into a tree specialist on staff and the cost associated with such an appointment.

B. Council Member John: Discussion of Smoking Ban

Council member Wyn John said the Public Health Council Committee reflected positive on a smoking ban and wanted to get the Council's response on this proposal. He said if the City doesn't take a stand one way or another to identify their position, then there would not be any weight at all for the Washington County to legislate for us. Wyn introduced the following motion because he felt quite strongly about a smoking ban.

M/No Second John/No Second – to direct the staff to prepare an ordinance prohibiting smoking in a public place where two or more people could gather.

Council member Dunn stated this is not something we should be wasting another minute on. Council member Johnston said he was in favor of an approach that would do the most good while doing the least amount of harm. He supported the concept of a smoking ban and the idea of a regional smoking ban.

Mayor Hunt suggested that they send a letter of support to the group being spearheaded by St Paul Mayor Randy Kelly, Minneapolis, who is coordinating a regional approach and offer to participate in the discussions.

M/S/P Johnston/John - to send a letter of support to Mayor Kelly offering to participate in the discussion for support of the program and send a letter to the Washington County Board to encourage them to adopt a countywide smoking ban .(Motion passed 4-1Dunn the County is not interested in a county wide ban)

Council adjourn the meeting at 9:42 p.m.

Respectfully submitted by Sharon Lumby, City Clerk

Resolution No. 2004-068 Approve Claims

Resolution No. 2004-069 Assessments for Hill Trail N./50th Street TABLED

Resolution No. 2004-070 Assessment for 2004 Overlay

Resolution No. 2004-071 Tapestry at Charlotte's Grove Concept Plan

Resolution No. 2004-072 Additional Claims

DRAFT

MINUTES APPROVED: August 17, 2004
LAKE ELMO CITY COUNCIL MINUTES

WEDNESDAY, AUGUST 4, 2004
(The Council meeting has been rescheduled from August 3, 2004
because of National Night Out)

1. AGENDA
2. MINUTES: July 20, 2004
3. PUBLIC INQUIRIES/INFORMATIONAL:
4. CONSENT AGENDA:
 - A. Resolution No. 2004-062 Approving Claims
 - B. Request for Meehan Family for an Extension of time to Record Final Plat
 - C. Ordinance Amending Definition for Building Height (POSTPONED)
 - D. Resolution No. 2004-062: Appointing Election Judges for Primary and General Election
 - E. Resolution No. 2004-063: Designating Polling Places for the Primary and General Election
5. FINANCE:
 - A. Schedule Meeting Date for Bond Resolution and Amend CIP
6. NEW BUSINESS
7. MAINTENANCE/PARK/FIRE/BUILDING:
 - A. Update on Fire Department Activities: Fire Chief Malmquist
8. CITY ENGINEER'S REPORT:
 - A. Landscape Security Release-Eagle Point Business Park
9. PLANNING, LAND USE & ZONING:
 - A. Resolution No. 2004-064: Request to MnDOT for Iris Avenue Street Sign
 - B. Fence Ordinance: Ordinance No. 97-137
 - C. Fence Moratorium Request at 55th Street N. (Postponed)
 - D. Limited Business Zoning District – Add Family Entertainment Center (Tabled at the request of the applicant)
 - E. Resolution No. 2004-065: Final Plat, OP Plat & Development Agreement; Whistling Valley Second Addition
10. CITY ATTORNEY'S REPORT:
11. CITY ADMINISTRATOR'S REPORT:
 - A. New Public Facilities: City Hall, Public Work Facilities and Possible Fire Station
12. CITY COUNCIL REPORTS
 - A. Mayor Hunt: Smoking Ban

Acting Mayor Dunn called the meeting to order at 7 p.m. in the Council chambers.
PRESENT: John, Dunn, Johnston, DeLapp, City Engineer Prew, City Attorney Filla,
City Planner Dillerud, Finance Director Tom Bouthilet and Administrator Rafferty.
ABSENT: Mayor Hunt

- C. Ordinance No. 97- Amending Definition for Building Height (Postponed to 8/17)
- D. Resolution No. 2004-062:Appointing Election Judges for Primary and General Election

M/S/P Johnston/DeLapp – to adopt Resolution No. 2004-062, Appointing Elections Judges for the September 14, 2004 Primary Election and the November 2, 2004 General Election. (Motion passed 4-0).

- E. Resolution No. 2004-063:Designating Polling Places for the Primary and General Election

M/S/P Johnston/DeLapp – to adopt Resolution No. 2004-063, Designating Polling Places for the September 14, 2004 Primary Election and the November 2, 2004 General Election. (Motion passed 4-0).

5. FINANCE

- A. Schedule Meeting Date for Bond Resolution and Amend CIP

The Council selected Tuesday, August 24, 2004, 7 p.m. to hold the Public Hearing for the Bond Resolution and Amend the CIP.

6. NEW BUSINESS:

7. MAINTENANCE/PARK/FIRE/BUILDING:

- A. Update on Fire Department Activities:Fire Chief Malmquist

Fire Chief Malmquist reported the Department was invited to two neighborhoods for National Night Out. The Department calls are down 40 to 50 calls from 2003. All of the Firefighters on staff are First Responders. The Department will be attending Fire Fighter Day at the Washington County Fair on Saturday.

8. CITY ENGINEER'S REPORT:

- A. Landscape Security Release-Eagle Point Business Park

Planner Dillerud reported two growing seasons have been completed for the landscape improvements at the Eagle Point Business Park (office condos on Eagle Point Blvd.). Mike Bouthilet has inspected the landscaping and reported the landscaping complies with the approved landscape plan for the site. He noted a handful of trees that had not survived have been replaced by the project developer. Staff recommended release of the \$89,900 Letter of Credit securing the landscape plan for this site.

M/S/P Johnston/DeLapp - to approve release of M&I Bank Letter of Credit #SB6244 securing the landscape improvements of the Eagle Point Business Park based on the Finding that the landscape improvements are complete per approved plans and the landscape materials have survived two growing seasons. (Motion passed 4-0).

M/S/P Johnston/Dunn – to amend the text in Section 302.02 Fence Materials, Subd. 3 – Chain Link or Cyclone Fences by striking “and shall be black or green in color”.
(Motion passed 3-1:DeLapp)

M/S/P Johnston/Dunn – to amend the text in Section 302.04 Temporary Fences, Subd. 1 – Defined to read “Temporary Fences shall be open to light and air over not less than “40%” of the fence surface area.” (Motion passed 4-0).

M/S/P Johnston/DeLapp – to amend the text in Section 302.06 Fences as Screening and Security as Required by This Code by adding “Item 4. No such screening shall be roofed or covered in any manner. (Motion passed 4-0).

The Council suggested that in Section 302.02 add Temporary Fences as exclusion to requiring a building permit. Council member Johnston asked if temporary fences are adequately defined. Attorney Filla responded that temporary fence definitions could have other fences; such as, garden, snow fences and swimming pool fences which are installed and removed on a seasonal basis.

M/S/P Johnston/DeLapp – to not require a building permit for temporary fences. (Motion passed 4-0).

Attorney Filla suggested adding the words “6 months administratively.”

M/S/P Johnston/John – to amend the text to read in Section 302.07, Item 1. Fence Permits Required: All such fences shall be removed by the property owner within 6 months of the termination of the keeping of Domestic Farm animals, unless an extension is specifically authorized by City Council action. (Motion passed 4-0).

M/S/P Johnston/John – to adopt Ordinance No. 97-137, Fence Ordinance, as amended. (Motion passed 4-0).

M/S/P Johnston/John to amend the agenda add 9B New Fence Ordinance and Repeal of Fence Moratorium. (Motion passed 4-0).

M/S/P Johnston/DeLapp – to repeal the Fence Moratorium. (Motion passed 4-0).

Planner Dillerud will address Council member Johnston’s concern on clarification of fences in the OHW setback in the shoreland ordinance.

C. Fence Moratorium Request at 55th Street North:

This agenda item was postponed to August 17th Council meeting per the request of resident, Tom McCormick.

D. Limited Business Zoning District – Add Family Entertainment Center:

This agenda item was tabled at the request of the applicant.

B. Confirmation of Captain Appointment

M/S/P Johnston/John – to confirm the appointment of Bruce Cohen to Captain of the Lake Elmo Fire Department. (Motion passed 4-0).

12. CITY COUNCIL REPORTS:

Council member DeLapp announced the Sierra Club will hold a Tour de Sprawl bicycle tour through the City on September 18th and are looking for the city to offer a squad escort along 10th Street.

M/S/P Johnston/DeLapp – to request the Washington County Sheriff's Department to work with the Sierra Club to provide a squad escort on 10th Street N. for the bicycle tour, Tour de Sprawl, on September 18, 2004. (Motion passed 4-0).

Administrator Rafferty reported there will be a workshop on the County-wide assessment proposal, Tuesday, August 10, 10:15 a.m., in the Washington County Board Room. The Supreme Court decision will come out on Thursday, 1 p.m.. He spoke to the Mayor of Minnetrista, which is experiencing similar problems with the Met Council.

Discussion on the smoking ban will be referred to the Public Health and Safety Council Committee. Discussion on purchase of a speed trailer in regard to issues on Highlands Trail will be added to the Public Works Council Committee agenda.

Council adjourn the meeting at 9:30 p.m.

Respectfully submitted by Sharon Lumby, City Clerk

Resolution No. 2004-061 Approve Claims

Resolution No. 2004-062 Appoint Election Judges

Resolution No. 2004-063 Designate Polling Places

Resolution No. 2004-064 Request to MnDOT for Iris Avenue Street Sign

Resolution No. 2004-065 Final Plat of Whistling Valley Second Addition

Resolution No. 2004-066 Call a Public Hearing on Assessments for 2004 Overlay

Resolution No. 2004-067 Call a Public Hearing on Assessments for Improvement of Hill Trail

Ordinance No. 97-137 Fence Ordinance

<p>Lake Elmo City Council September 7, 2004</p>	<p>Agenda Section: PUBLIC INFORMATIONAL</p>	<p><u>No 3B.</u></p>
<p><u>Agenda Item: Kathi Pelnar, Animal Control Officer Ordinance Relating to Confinement of Dogs</u></p>		
<p><u>Background Information for September 7, 2004</u> At the August 17th meeting, the Council tabled adoption of the Ordinance Relating to Confinement of Dogs. At the invitation of the Council, Kathi Pelnar will be present to answer any questions.</p>		
<p><u>Action Items:</u> Motion/Second - to adopt Ordinance No. 97-140 Relating to Confinement of Dogs, as presented or amended.</p>	<p><u>Person responsible:</u> S.Lumby</p>	

recommended for approval by the City Attorney, the Fire Chief and the City Administrator.

M/S/P DeLapp/Johnston – to approve the Mayor, City Administrator, and Fire Chief sign the Mutual Aid Agreement with St. Croix Valley and Hudson Fire Service. (Motion passed 5-0).

C. Disposal of Fire Equipment

M/S/P Dunn/DeLapp – to approve the Mayor, City Administrator and Fire Chief sign an agreement to transfer outdated surplus Air Pack equipment to receiving city. (Motion passed 5-0).

D. Animal Ordinance Amendment

The Community Improvement Committee has studied the current ordinance regulating restraining of dogs. The CIC has recommended that a minor change to the dog ordinance be adopted. The change proposed requires that a dog owner employ an active restraint system if the dog is left outside and the owners are not home.

Rod Sessing and Council member DeLapp questioned the relevancy of the property owner being home or not and why penalize them for when the owner is not home. Council member Johnston stated that his interpretation of the opinion of animal control is that invisible fencing was not efficiently effective and additional protection was a good policy. Ann Smith, Vice Chair of the CIC, stated if the dogs stay in the invisible fence, the property owner will not get fined. This would protect people in the future when the owner is not home all day long. Joan Ziertman, CIC member, stated she would rather see extra enforcement when a person is gone a long time. Council member Dunn said she wasn't convinced that invisible fences were causing a problem in the city and was not prepared to make a change to the dog ordinance.

Animal Control Officer Kathi Pelnar provided a year end report listing the number of dogs picked up wearing invisible fence collars. For both 2003 and 2004 that number was four dogs. The Council wanted to talk with the ACO to try to understand the actual magnitude of the problem.

M/S/P Johnston/ Dunn – to invite Kathie Pelnar, ACO, to come to the September 7th Council meeting to discuss animal control under the Public Information section of the meeting agenda. (Motion passed 5-0).

E. Purchase offer for 3585 Laverne Avenue

Council member Johnston stated he was in favor of a city center and buying this property in question because it is contiguous to the Lions Ball Field. He suggested inviting residents that would be affected by a proposed new city center to a public hearing. The

CITY OF LAKE ELMO
COUNTY OF WASHINGTON
STATE OF MINNESOTA
ORDINANCE NO. _____

AN ORDINANCE RELATING TO CONFINEMENT OF DOGS

The Lake Elmo City Council hereby ordains that Section 1320.025 is added to the City Code to read as follows:

1320.025 **Confinement of Dogs.** When a dog owner is at home, a dog, except those classified as potentially dangerous or dangerous dogs, shall be confined to the dog owners property by owner supervision, kennel, physical or invisible fencing, or by a chain securely anchored to a structure or to the ground. Invisible fencing is not a permissible means of confinement if a dog owner is not at home. Potentially dangerous or dangerous dogs shall be confined in a proper enclosure.

ADOPTION DATE: Passed by the Lake Elmo City Council on the ____ day of _____, 2004.

EFFECTIVE DATE: This Ordinance shall be effective the day following its publication.

Dated: _____, 2004

CITY OF LAKE ELMO

By: _____
Lee Hunt
Its: Mayor

ATTEST

Martin Rafferty
Its: City Administrator

Lake Elmo City Council August 17, 2004	Agenda Section: CITY ADMINISTRATOR'S REPORT	<u>No. 11. D</u>
<u>Agenda Item: Modification to Dog Ordinance</u>		
<u>Background Information for August 17, 2004:</u> The Community Improvement Committee (CIC) has studied the current Ordinance regulating restraint of dogs. Upon study and review the CIC has recommended that a minor change to the dog ordinance be adopted. The change proposed requires that a dog owner employ an active restraint system if the dog is left outside and the owner(s) are not at home. The FLLP Council Committee has recommended the change be made to the current ordinance.		
<u>Action Items:</u> Resolution adopting a modification to the Dog Ordinance requiring an active restraint of a dog; if the animal is left out side when the owner is not at home.	<u>Person responsible:</u> Martin Rafferty	
<u>Attachments:</u> Ordinance modification at Council		

End of Year Report 2003

City of Lake Elmo

Animal Control

	2003	2004
Total Number of calls Received	145	81
Total Calls Requiring response	124	72
Total Calls handled over the phone or With only a warning letter	21	09
Total Viscous Dog Calls	01	02
Total Number of dogs picked up	46	20
Total Number of Cats picked up	57	39
Total Number of Pick ups with collar and Identification tags on (dogs only)	09	07
Total Number of picks ups with collars only (Dogs only)	16	07
Total Number of dogs picked up wearing Invisible fence collars	04	04

Submitted by:

Kathi Pelnar CVT, CHI
Animal Warden

<u>Mayor</u> Lee Hunt	No. 4A
<u>Councilmembers</u> Steve DeLapp Susan Dunn Dean Johnston	Agenda Section: Consent Agenda Agenda Item: Planning Commission Resignations Date: September 7, 2004

Background Information for September 7, 2004.

Planning Commissioner Jeff Berg resigned his commission on August 20, 2004. Planning Commissioner Jim Van Pelt resigned his commission on August 30, 2004.

Jeff Berg became a Full Voting Member of the Planning Commission in January, 1996. His term would have expired on December 31, 2004. The City Council accepts his resignation, and thanks him for his service to the residents of Lake Elmo.

Motion _____, Second _____, to accept the resignation of Planning Commissioner Jeff Berg, and to send a letter of appreciation for his contributions to the residents of the City of Lake Elmo.

Jim Van Pelt became a Full Voting Member of the Planning Commission in May, 2004, taking over the term of Julie Bunn that expires December 31, 2006. The City Council accepts his resignation and thanks him for his service to the residents of Lake Elmo.

Motion _____, Second _____, to accept the resignation of Planning Commissioner Jim Van Pelt, and to send a letter of appreciation for his contributions to the residents of the City of Lake Elmo.

The Planning Commission now has seven Full Voting Members, and two alternates. First Alternate Planning Commissioner Thomas Meldahl would like to remain as an Alternate Member through the summer. Second Alternate Planning Commissioner Charlie Schneider should be appointed as a Full Voting Member to finish the term of Jeff Berg that expires on December 31, 2004.

Motion _____, Second _____, to appoint Charlie Schneider as Full Voting Member of the Planning Commission.

The Planning Commission now has two openings (one Full Voting Member and one Alternate Member) and three applications on file. Those applicants are Gloria Knoblauch, LeRoy Rossow, and Thomas Armstrong. Staff requests direction for advertising for and/or interviewing applicants.

August 20, 2004

To: City of Lake Elmo
Mayor & City Council

From: Jeff Berg

RE: Resignation from the Planning Commission

I hereby submit my resignation from the City of Lake Elmo Planning Commission.

It has been a pleasure to be able to serve on the Planning Commission for the past 8+ years. I wish you well in continuing efforts to preserve the rural character of the City of Lake Elmo.

Sincerely,

Jeffrey J. Berg

P.S. Get that Old Village Plan complete!

P.P.S. Keep the website up to date so I can stay current on City of Lake Elmo news!

RECEIVED
AUG 20 2004

4B.

**CITY OF LAKE ELMO
WASHINGTON COUNTY, MINNESOTA**

**RESOLUTION NO. 2004-074
RESOLUTION APPROVING CLAIMS**

BE IT RESOLVED THAT Claim Numbers 213, 214, DD230, 26061 through 26074, were used for Staff payroll dated August 19, 2004, Claim Numbers 215, 216, DD 231, 26076 through 26086 were used for staff dated September 02, 2004, Claim 26075, 26087 through 26152 in the total amount of \$379805.01 are hereby approved.

ADOPTED, by the Lake Elmo City Council on the 7th day of September, 2004.

Lee Hunt
Mayor

ATTEST:

Martin J. Rafferty
City Administrator

Accounts Payable Computer Check Proof List

User: administrator
Printed: 09/02/2004 - 12:00 PM



Invoice No	Description	Amount	Payment Date	Acct Number	Reference
Vendor:ALERTALL 4080195	Alert-All Fire Prev. materials - hats, booklets Check Total:	902.76 902.76	09/07/2004	Check Sequence: 1 101-420-2220-42090	ACH Enabled: No
Vendor:AmeriMar 10862	AmeriMark Direct Recycling materials Check Total:	485.42 485.42	09/07/2004	Check Sequence: 2 101-430-3200-44300	ACH Enabled: No
Vendor:AMERTEST 2042580-IN	American Test Center Fire truck 3175 tested Check Total:	495.00 495.00	09/07/2004	Check Sequence: 3 101-420-2220-44040	ACH Enabled: No
Vendor:ANCOM 39200	ANCOM COMMUNICATIONS, INC. Updated equipment Check Total:	3,398.27 3,398.27	09/07/2004	Check Sequence: 4 101-420-2220-43230	ACH Enabled: No
Vendor:ARAM 629-5528661 629-5537878	Aramark Cleaning supplies for City Hall Cleaning supplies for City Hall Check Total:	46.68 46.68 93.36	09/07/2004 09/07/2004	Check Sequence: 5 101-410-1940-44010 101-410-1940-44010	ACH Enabled: No
Vendor:ATTWI 023-2750230	AT&T Wireless Floater phone - FD Check Total:	20.47 20.47	09/07/2004	Check Sequence: 6 101-420-2220-43210	ACH Enabled: No
Vendor:AVAYA 2719182861	AVAYA Inc. Monthly telephone maint.	150.36	09/07/2004	Check Sequence: 7 101-410-1940-44040	ACH Enabled: No

Invoice No	Description	Amount	Payment Date	Acct Number	Reference
	Check Total:	150.36			
Vendor:BAHR01 ROAD DEP: 3583	Bahr Construction Returned Rd. Dep. -Permit 3583 Check Total:	1,000.00 1,000.00	09/07/2004	Check Sequence: 8 803-000-0000-22900	ACH Enabled: No
Vendor:CARPEN 79348	Carpenter's Small Engine Chain Saw, Vent. Kit Check Total:	1,151.74 1,151.74	09/07/2004	Check Sequence: 9 101-420-2220-45800	ACH Enabled: No
Vendor:CENTPOW 291573	Century Power Equipment Engine Oil Check Total:	36.64 36.64	09/07/2004	Check Sequence: 10 101-430-3100-42150	ACH Enabled: No
Vendor:DENOMA REFUND	Michael & LindaDenoma Variance Fee Refund Check Total:	620.00 620.00	09/07/2004	Check Sequence: 11 803-490-9070-44300	ACH Enabled: No
Vendor:DWINC 1025	D.W. INC. Husqvarna String Trimmer Check Total:	51.55 51.55	09/07/2004	Check Sequence: 12 101-450-5200-44040	ACH Enabled: No
Vendor:ELMOLUM 0126316 0126545	Elmo's Lumber & Plywood Bolts, Nuts, Floor Dry Supplies Check Total:	14.45 19.36 33.81	09/07/2004 09/07/2004	Check Sequence: 13 101-450-5200-42230 101-420-2220-42230	ACH Enabled: No
Vendor:EMERGAPP 18872	Emergency Apparatus Maint. Eng. 3183 - dead trans. key pad Check Total:	2,142.95 2,142.95	09/07/2004	Check Sequence: 14 101-420-2220-44040	ACH Enabled: No
Vendor:FARNPLN 1019093 1068605	Farm Plan Purchase - Polifus Purchase - Polifus Check Total:	58.00 47.89 105.89	09/07/2004 09/07/2004	Check Sequence: 15 101-450-5200-44040 101-450-5200-44040	ACH Enabled: No
Vendor:FOUR 23-037148	Four Seasons Service Supplies - City Hall	29.60	09/07/2004	Check Sequence: 16 101-410-1940-44300	ACH Enabled: No

Invoice No	Description	Amount	Payment Date	Acct Number	Reference
	Check Total:	29.60			
Vendor:FXL September 2004	FXL, Inc. Assessing Svcs for 09/2004 Check Total:	1,700.00 1,700.00	09/07/2004	Check Sequence: 17 101-410-1550-43100	ACH Enabled: No
Vendor:GENESIS IVC00070 IVC00070 IVC00070 IVC00070 IVC00086	Next Genesis Productions Firebox update and e-mail Fax Modern PW Printer fixed Monitor installed Repair wireless Check Total:	125.00 106.50 50.00 25.00 50.00 356.50	09/07/2004 09/07/2004 09/07/2004 09/07/2004 09/07/2004	Check Sequence: 18 101-410-1520-43180 101-410-1520-43185 101-430-3100-44040 101-410-1910-44300 101-410-1520-43180	ACH Enabled: No
Vendor:GWHIZ 3549	G-Whiz Lettering, Inc. Hats and shirts - Fire Dept. Check Total:	767.00 767.00	09/07/2004	Check Sequence: 19 101-420-2220-44170	ACH Enabled: No
Vendor:H&LMESAB 62793	H&L Mesabi 29 Replacement Blades Check Total:	2,709.84 2,709.84	09/07/2004	Check Sequence: 20 101-430-3100-42210	ACH Enabled: No
Vendor:HAWKINS 641451	Hawkins Chemical Hydrofluosilicic Acid Check Total:	325.65 325.65	09/07/2004	Check Sequence: 21 601-494-9400-42160	ACH Enabled: No
Vendor:Johnson 09/2004	Johnson Construction Rental - Storage Unit #12 Check Total:	90.00 90.00	09/07/2004	Check Sequence: 22 101-420-2220-44120	ACH Enabled: No
Vendor:LEAGMN 1-000018421 1-000018452 1-000018452 1-000018452	League of MN Cities Event - for Lee Hunt and Steve DeLapp Event - for Susan Dunn Event - for Marty Rafferty Event - for Chuck Dillerud Check Total:	630.00 315.00 230.00 315.00 1,490.00	09/07/2004 09/07/2004 09/07/2004 09/07/2004	Check Sequence: 23 101-410-1110-44370 101-410-1110-44370 101-410-1320-44370 101-410-1910-44370	ACH Enabled: No
Vendor:LEOIL S01203	Lake Elmo Oil, Inc. Fuel - FD	288.18	09/07/2004	Check Sequence: 24 101-420-2220-42120	ACH Enabled: No

Invoice No	Description	Amount	Payment Date	Acct Number	Reference
S01208	Fuel - Parks Check Total:	36.05 324.23	09/07/2004	101-450-5200-42120	
Vendor:LESCO 11347338	Lesco, Inc. Strip paint Check Total:	97.45 97.45	09/07/2004	Check Sequence: 25 101-450-5200-42250	ACH Enabled: No
Vendor:LINDVENN 287691-0840	Lindquist & Vennum Check Total:	735.35 735.35	09/07/2004	Check Sequence: 26 101-410-1940-43020	ACH Enabled: No
Vendor:MALMQ CLAIM TRAVEL EXP. CLA WOODBURY DAYS	GregMalmquist Reimbursement for April, May, June, July Int'l Fire Chiefs Conference Registration for Woodbury Days Tournamen Check Total:	200.00 600.00 90.00 890.00	09/07/2004 09/07/2004 09/07/2004	Check Sequence: 27 101-420-2220-43210 101-420-2220-43310 101-420-2220-44330	ACH Enabled: No
Vendor:MARONEYS 055321 055321 055321	Maroney's Sanitation, Inc Refuse - Parks Refuse - City Hall Refuse - City Garage Check Total:	183.96 95.89 95.89 375.74	09/07/2004 09/07/2004 09/07/2004	Check Sequence: 28 101-450-5200-43840 101-410-1940-43840 101-430-3100-43840	ACH Enabled: No
Vendor:MENARDSO 49526 52631	Menards - Oakdale For PW Lock Keys Check Total:	39.04 17.97 57.01	09/07/2004 09/07/2004	Check Sequence: 29 101-430-3100-42150 101-420-2220-42400	ACH Enabled: No
Vendor:MENARDST 10596	Menards - Stillwater Washer fluid and batteries for FD Check Total:	50.99 50.99	09/07/2004	Check Sequence: 30 101-420-2220-44300	ACH Enabled: No
Vendor:METCOU Q4 Cost All.	Metropolitan Council Q4 Cost Allocation Check Total:	9,058.40 9,058.40	09/07/2004	Check Sequence: 31 602-495-9450-44300	ACH Enabled: No
Vendor:METROCA 01744794	Metrocall Inc. Fire Dept.	83.21	09/07/2004	Check Sequence: 32 101-420-2220-43210	ACH Enabled: No

Invoice No	Description	Amount	Payment Date	Acct Number	Reference
	Check Total:	83.21			
Vendor:MILLEREX 9782	Miller Excavating, Inc. Grading on 07/08 and 07/22 Check Total:	1,000.88 1,000.88	09/07/2004	Check Sequence: 33 101-430-3100-43150	ACH Enabled: No
Vendor:MNDOH 1820009	MN Department of Health Community Water Supply Svc. Conn. Fee Check Total:	816.00 816.00	09/07/2004	Check Sequence: 34 601-494-9400-43820	ACH Enabled: No
Vendor:MUSCO 114204	Musco Sports Lighting, LLC Lights for Baseball field-remaining bal. Check Total:	16,784.37 16,784.37	09/07/2004	Check Sequence: 35 404-480-8000-45300	ACH Enabled: No
Vendor:NEXTEL 761950227-017 761950227-017 761950227-017 761950227-017	Nextel Communications Cell Phones - Office Cell Phone - Jim McNamara Cell Phones - PW Cell Phones - Mike B. Check Total:	208.20 32.64 355.11 16.32 612.27	09/07/2004 09/07/2004 09/07/2004 09/07/2004 09/07/2004	Check Sequence: 36 101-410-1940-43210 101-420-2400-43210 101-430-3100-43210 101-450-5200-43210	ACH Enabled: No
Vendor:NORTHOO 0561023792 0562024267	Retail ServicesNorthern Tool & Equipment Rotating Beacon Mag. Load Binder, 8" wedge Check Total:	53.24 62.80 116.04	09/07/2004 09/07/2004	Check Sequence: 37 101-430-3100-42400 101-430-3100-42150	ACH Enabled: No
Vendor:NORTHS 24-9281	Northern Traffic Supply Inc. 4 Stop signs, 8 4-way signs Check Total:	323.76 323.76	09/07/2004	Check Sequence: 38 101-430-3100-42260	ACH Enabled: No
Vendor:PELNAR August 2004	KathiPelnar Animal Control for August 2004 Check Total:	801.99 801.99	09/07/2004	Check Sequence: 39 101-420-2700-43150	ACH Enabled: No
Vendor:PLUNKETT 389440	Plunkett's Pest Control Monthly Extermination - August Check Total:	55.38 55.38	09/07/2004	Check Sequence: 40 101-410-1940-44010	ACH Enabled: No

Invoice No	Description	Amount	Payment Date	Acct Number	Reference
Vendor:POLFUS 1019871	Polfus Implement, Inc New fuel shut-off solenoid installed Check Total:	359.76 359.76	09/07/2004	Check Sequence: 41 101-450-5200-44040	ACH Enabled: No
Vendor:PRESS 8/17 - 8/23	StevenPress Cable Operator - 08/17, 08/23 Check Total:	80.00 80.00	09/07/2004	Check Sequence: 42 101-410-1320-44300	ACH Enabled: No
Vendor:QWEST 651714-2209 456	Qwest Hudson Lift Station Check Total:	36.20 36.20	09/07/2004	Check Sequence: 43 602-495-9450-43210	ACH Enabled: No
Vendor:RAKIND 293473 293473	RAK Industries Safety cans Safety cans Check Total:	314.95 314.95 629.90	09/07/2004 09/07/2004	Check Sequence: 44 101-430-3100-42210 101-450-5200-42210	ACH Enabled: No
Vendor:ROGERS 11758 11795	Rogers Printing Services 3rd Edition Newsletters Forms And Envelopes for water bills Check Total:	1,117.19 200.22 1,317.41	09/07/2004 09/07/2004	Check Sequence: 45 101-410-1320-43090 601-494-9400-42030	ACH Enabled: No
Vendor:RUD 8/16-8/26 8/16-8/26 8/16-8/26	DianePrince-Rud Cleaning City Hall Cleaning Fire Dept. Cleaning Supplies Check Total:	360.00 360.00 27.32 747.32	09/07/2004 09/07/2004 09/07/2004	Check Sequence: 46 101-410-1940-44010 101-420-2220-44010 101-410-1940-42110	ACH Enabled: No
Vendor:SATELLIT 24180612	Satelrite Shelters, Inc. Mobile office 08/19-09/15 Check Total:	319.50 319.50	09/07/2004	Check Sequence: 47 101-420-2400-44120	ACH Enabled: No
Vendor:SEH 0118992	Short Elliott Hendrickson, Inc Trail plan dev. - for 07/01-07/31 Check Total:	5,600.00 5,600.00	09/07/2004	Check Sequence: 48 404-480-8000-43050	ACH Enabled: No
Vendor:STILLGAZ 00003695 00003701	Stillwater Gazette Notice for 08/09 Meeting Election Filing Notice	14.70 25.20	09/07/2004 09/07/2004	Check Sequence: 49 101-410-1320-43510 101-410-1320-43510	ACH Enabled: No

Invoice No	Description	Amount	Payment Date	Acct Number	Reference
00003721	Assessment Hearings	168.00	09/07/2004	101-410-1320-43510	
00003722	Public Hearing Notice, Denoma Variance	25.20	09/07/2004	101-410-1320-43510	
00003724	CIP Bonds Hearing Notice	27.30	09/07/2004	101-410-1320-43510	
00003726	Assessment Hearings	168.00	09/07/2004	101-410-1320-43510	
00003729	Ordinance 97-137	147.00	09/07/2004	101-410-1320-43510	
00003731	Hearing Notice	21.00	09/07/2004	101-410-1320-43510	
	Check Total:	596.40			
Vendor: Streiche	STREICHER'S			Check Sequence: 50	ACH Enabled: No
1210294	Name tags - Capt. Cohen	21.30	09/07/2004	101-420-2220-44170	
	Check Total:	21.30			
Vendor: SUNSET	Sunset Printing \$ Adv. Spec.Co			Check Sequence: 51	ACH Enabled: No
55699	Imprinted Supplies	197.72	09/07/2004	101-420-2220-42090	
	Check Total:	197.72			
Vendor: SUNTURF	Sun Turf, Inc.			Check Sequence: 52	ACH Enabled: No
4060099-00	Drag Mat	436.65	09/07/2004	101-450-5200-42250	
	Check Total:	436.65			
Vendor: TASC	T. A. Schifsky & Sons			Check Sequence: 53	ACH Enabled: No
33867	Asphalt	46.41	09/07/2004	101-430-3100-42240	
33893	Asphalt	47.05	09/07/2004	101-430-3100-42240	
	Check Total:	93.46			
Vendor: TESSMAN	Tessman Company			Check Sequence: 54	ACH Enabled: No
SO53733-IN	Weed Killer	338.20	09/07/2004	101-450-5200-42160	
SO53733-IN	Chalk	25.30	09/07/2004	101-450-5200-42250	
	Check Total:	363.50			
Vendor: TKDA	TKDA, Inc.			Check Sequence: 55	ACH Enabled: No
200400000622	VFWBallfield Lights	396.06	09/07/2004	404-480-8000-43030	
200400000623	Reviews, Meetings, Reimb	2,415.02	09/07/2004	101-410-1930-43030	
200400000623	Planning, Concepts, Reviews - City Hall	8,596.78	09/07/2004	410-480-8000-43030	
200400000623	Heritage Farms Water Service Repair	152.21	09/07/2004	601-494-9400-43030	
200400000623	Street Project/Budget, Paving	1,217.70	09/07/2004	409-480-8000-43030	
200400000623	Winkle Pump Claim	50.74	09/07/2004	602-495-9450-43030	
200400000623	Carriage Station, Whistling Vly, Tapestry	2,384.66	09/07/2004	803-490-9070-43030	
200400000623	Ponds	937.33	09/07/2004	603-496-9500-43030	
200400000624	Meetings	200.00	09/07/2004	101-410-1930-43030	

Invoice No	Description	Amount	Payment Date	Acct Number	Reference
200400000625	Hill Trail Valley	1,967.47	09/07/2004	409-480-8000-43030	
200400000626	Surface Water Mgmt Plan	1,774.58	09/07/2004	603-496-9500-43030	
200400000627	2004 Overlays	101.48	09/07/2004	409-480-8000-43030	
	Check Total:	20,194.03			
Vendor: TRKUTI	Truck Utilities	37.28	09/07/2004	Check Sequence: 56	ACH Enabled: No
0130849	Mudflaps	37.28		101-430-3100-42210	
	Check Total:				
Vendor: VISA	Visa	40.00	09/07/2004	Check Sequence: 57	ACH Enabled: No
Acct. 9777	Sensible Land Use - Ch. Dillerud	40.00	09/07/2004	101-410-1910-44370	
Acct. 9777	Sensible Land Use - M. Rafferty	40.00	09/07/2004	101-410-1320-44370	
Acct. 9785	PW Software	149.95	09/07/2004	101-430-3100-44300	
	Check Total:	229.95			
Vendor: WAS-LAND	Washington County Surveyor	28.76	09/07/2004	Check Sequence: 58	ACH Enabled: No
1004562	2004 Plat Book	28.76		101-410-1910-44350	
	Check Total:				
Vendor: WAS-REC	Washington County Recorder	19.50	09/07/2004	Check Sequence: 59	ACH Enabled: No
1174	Resolution 2000-041	19.50		101-410-1320-44300	
	Check Total:				
Vendor: WORKWELL	Workwell Occupational Health	733.00	09/07/2004	Check Sequence: 60	ACH Enabled: No
057919	FD Physicals	733.00		101-420-2220-43050	
	Check Total:				
Vendor: XCEL	Xcel Energy	142.09	09/07/2004	Check Sequence: 61	ACH Enabled: No
0044-445-749239	Sofball Field	23.13	09/07/2004	101-450-5200-43810	
0073-736-544230	Street Lights at 3014 Jamley Ave	146.60	09/07/2004	101-430-3160-43810	
0084-044-646238	4259 Jamaca	19.33	09/07/2004	101-430-3100-43810	
0176-825-022238	Traffic Lights I94&Inwood	338.22	09/07/2004	101-430-3160-43810	
0417-949-252239	City Hall	23.36	09/07/2004	101-410-1940-43810	
0446-544-592238	Traffic Lights Manning/Stillwater	33.47	09/07/2004	101-430-3160-43810	
0573-240-678238	11194 Upper 33rd	13.64	09/07/2004	101-450-5200-43810	
0592-147-254239	Pebble Park	30.10	09/07/2004	101-450-5200-43810	
0614-943-270238	Traffic at 998 Inwood	17.50	09/07/2004	101-430-3160-43810	
0777-146-175238	Tennis Courts	679.77	09/07/2004	101-450-5200-43810	
1278-842-757239	3303 Langley Ct. N	42.43	09/07/2004	601-494-9400-43810	
1427-822-590239	8860 Hudson Blvd		09/07/2004	602-495-9450-43810	

Invoice No	Description	Amount	Payment Date	Acct Number	Reference
1577-643-354238	Fire Dept.	150.37	09/07/2004	101-420-2220-43810	
1684-846-045237	2759 Legion Ave	11.56	09/07/2004	602-495-9450-43810	
1808-181-287238	3675 Layton Ave N	4.48	09/07/2004	101-450-5200-43810	
1957-348-187238	11062 34th St. N	13.29	09/07/2004	602-495-9450-43810	
2175-049-940238	3511 Laverne Ave N	47.79	09/07/2004	101-450-5200-43810	
	Check Total:	1,737.13			
Vendor: XCELNSP	Xcel Energy				ACH Enabled: No
3675 LAYTON AVE	Wire overhead service at 3675 Layton Ave	12,205.37	09/07/2004	404-480-8000-45300	
	Check Total:	12,205.37			
Vendor: YOUTHS	The Youth's Safety Company				ACH Enabled: No
73194	Fire prev. materials	562.78	09/07/2004	101-420-2220-42090	
	Check Total:	562.78			
	Total for Check Run:	96,886.80			
	Total Number of Checks:	63			

<p>Lake Elmo City Council September 7, 2004</p>	<p>Agenda Section: CONSENT AGENDA</p>	<p><u>No 4C.</u></p>
<p><u>Agenda Item:</u> Resolution No. 2004-078, Approving Partial Payment No. 4 to T.A. Schifsky for Hill Trail North and 50th Street Reconstruction.</p>		
<p><u>Background Information for September 7, 2004</u></p> <p>In his memo dated September 1, 2004 the City Engineer reported T.A. Schifsky has completed the final siding repair work and the project will be completed the week of September 6, 2004.</p> <p>The City Engineer recommends approval of Partial Payment No. 4 to T.A. Schifsky in the amount of \$77,893.32. This pay request covers the wearing course paving and initial turf establishment work done last spring.</p>		
<p><u>Action Items:</u> Motion/Second - to adopt Resolution No. 2004-078 Approving Partial Payment No. 4 in the amount of \$77,893.32 for Hill Trail North and 50th Street North Reconstruction to T.A. Schifsky, verified by the City Engineer's memo dated September 1, 2004.</p>	<p><u>Person responsible:</u> S. Lumby</p>	

**CITY OF LAKE ELMO
WASHINGTON COUNTY, MINNESOTA**

RESOLUTION NO. 2004-078

**A RESOLUTION APPROVING PARTIAL PAYMENT NO. 4
TO T.A. SCHIFSKY
FOR HILL TRAIL NORTH AND 50TH STREET NORTH**

BE IT RESOLVED, that the Lake Elmo City Council hereby approves Partial Payment No. 4 in the amount of \$77,893.32 to T.A. SCHIFSKY for work completed on Hill Trail North and 50th Street North, verified by the City Engineer in his memo dated September 1, 2004.

ADOPTED, by the Lake Elmo City Council the 7th day of September, 2004.

Lee Hunt, Mayor

ATTEST:

Martin J. Rafferty, City Administrator

PP#4Schifsky

TKDA

ENGINEERS • ARCHITECTS • PLANNERS

1500 Piper Jaffray Plaza
444 Cedar Street
Saint Paul, MN 55101-2140

(651) 292-4400
(651) 292-0083 Fax
www.tkda.com

September 1, 2004

Honorable Mayor and City Council
City of Lake Elmo, Minnesota

Re: Hill Trail North and 50th Street North
Street Reconstruction
City of Lake Elmo, Minnesota
TKDA Commission No. 12170-03

Dear Mayor and City Council:

The contractor is completing the final sodding repair work this week. We expect the project to be complete by next week.

This pay request covers the wearing course paving and initial turf establishment work done last spring.

City Council Action Requested

Approve Partial Payment No. 4 in the amount of \$77,893.32.

Sincerely,

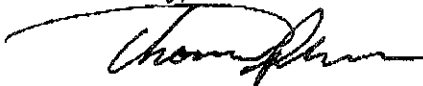

Thomas D. Prew, P.E.
Project Manager

TDP:mrk



ENGINEERS • ARCHITECTS • PLANNERS

1600 Piper Jaffray Plaza
444 Cedar Street
Saint Paul, MN 55101-2140

(651) 292-4400
(651) 292-0083 Fax
www.tkda.com

Comm. No. 12170-02 Cert. No. 4 St. Paul, MN, August 30, 20 04

To City of Lake Elmo, Minnesota Owner

This Certifies that T.A. Schifsky & Sons, Inc. Contractor

For Hill Trail North and 50th Street North Street Reconstruction

Is entitled to Seventy-Seven Thousand Eight Hundred Ninety-Three Dollars and 32/100 -- (\$77,893.32)

being 4th estimate for partial payment on contract with you dated August 8, 2003

Received payment in full of above Certificate. TKDA

T.A. Schifsky & Sons, Inc.
_____, 20____



Thomas D. Prew, P.E.

RECAPITULATION OF ACCOUNT

	CONTRACT PLUS EXTRAS	PAYMENTS	CREDITS
Contract price plus extras	\$ 401,646.35		
All previous payments		\$ 334,988.16	
All previous credits			
Extra No.			
Change Order No. 1	\$ 10,464.87		
" "			
" "			
" "			
Credit No.			\$ -
" "			
" "			
" "			
AMOUNT OF THIS CERTIFICATE		\$ 77,893.32	
Totals	\$ 412,111.22	\$ 412,881.48	\$ -
Credit Balance			
There will remain unpaid on contract after payment of this Certificate		\$ (770.26)	
	\$ 412,111.22	\$ 412,111.22	\$ -

TKDA
Engineers-Architects-Planners Saint Paul, Minnesota 55101

PERIODICAL ESTIMATE FOR PARTIAL PAYMENTS

Estimate No. 4 Period Ending August 26, 2004 Page 1 of 1 Comm. No. 12170-02
 Contractor T. A. Schifsky & Sons Original Contract Amount \$401,646.35
 Project Hill Trail North and 50th Street North Street Reconstruction
 Location City of Lake Elmo, Minnesota

Total Contract Work Completed	\$	<u>424,147.21</u>
Total Approved Credits	\$	<u>0.00</u>
Total Approved Extra Work Completed (Change Order No. 1)	\$	<u>10,464.87</u>
Approved Extra Orders Amount Completed	\$	<u>10,464.87</u>
Total Amount Earned This Estimate	\$	<u>434,612.08</u>

Less Approved Credits	\$	<u>0.00</u>
Less <u>5</u> % Retained	\$	<u>21,730.60</u>
Less Previous Payments	\$	<u>334,988.16</u>
Total Deductions	\$	<u>356,718.76</u>
Amount Due This Estimate	\$	<u>77,893.32</u>

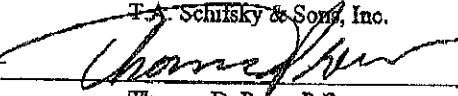
Contractor T. A. Schifsky & Sons, Inc. Date _____
 Engineer  Date August 30, 2004
 Thomas D. Prév, P.E.

ESTIMATE NO. 4

PERIOD ENDING: August 26, 2004

HILL TRAIL NORTH AND 50TH STREET RECONSTRUCTION
 CITY OF LAKE ELMO, MINNESOTA
 COMMISSION NO. 12170-02

ITEM NO.	DESCRIPTION	UNIT	CONTRACT QUANTITY	QUANTITY TO DATE	UNIT PRICE	AMOUNT TO DATE
HILL TRAIL NORTH AND 50TH STREET RECONSTRUCTION						
1	MOBILIZATION	LS	1.0	1.0	\$ 19,000.00	\$ 19,000.00
2	CLEARING	TR	25.0	25.0	\$ 100.00	\$ 2,500.00
3	GRUBBING	TR	25.0	25.0	\$ 100.00	\$ 2,500.00
4	REMOVE SEWER PIPE (STORM)	LF	250.0	357.0	\$ 12.00	\$ 4,284.00
5	REMOVE CONCRETE DRIVEWAY	SY	60.0	83.68	\$ 3.10	\$ 259.41
6	REMOVE BIT SURFACE	SY	13,700.0	13525.48	\$ 1.00	\$ 13,525.48
7	REMOVE BURIED DEBRIS	CY	150.0	-	\$ 26.25	\$ -
8	REMOVE CATCH BASIN	EA	3.0	5.0	\$ 375.00	\$ 1,875.00
9	SALVAGE PLATE BEAM GUARD RAIL	LF	100.0	-	\$ 4.75	\$ -
10	SAW CUT BITUMINOUS PAVEMENT	LF	750.0	780.0	\$ 3.00	\$ 2,340.00
11	SAW CUT CONCRETE PAVEMENT	LF	80.0	98.0	\$ 4.00	\$ 384.00
12	COMMON EXCAVATION (P)	CY	5,563.0	5,563.0	\$ 8.30	\$ 35,046.90
13	COMMON EXCAVATION FOR POND	CY	400.0	400.0	\$ 6.30	\$ 2,520.00
14	SUBGRADE EXCAVATION	CY	2,000.0	366.1	\$ 6.30	\$ 2,308.43
15	TOPSOIL BORROW (LV)	CY	200.0	256.0	\$ 14.20	\$ 3,635.20
16	COMMON LABORERS	HR	20.0	-	\$ 65.00	\$ -
17	WATER FOR DUST CONTROL	MGAL	40.0	10.50	\$ 25.00	\$ 262.50
18	AGGREGATE BASE CLASS 6	TN	11,000.0	10,964.34	\$ 9.00	\$ 98,679.06
19	SAWED/SEALED JOINT	LF	1,775.0	-	\$ 1.55	\$ -
20	4" THICK BITUMINOUS PATCH	SY	50.0	-	\$ 19.50	\$ -
21	TYPE LV AGG. 4 WEARING COURSE	TN	1,370.0	1,206.50	\$ 36.00	\$ 46,314.00
22	TYPE LV AGG. 3 NON-WEARING COURSE	TN	1,830.0	1,438.45	\$ 35.50	\$ 51,064.98
23	TYPE LV AGG. 4 WEARING COURSE 2" THICK FOR DRIVEWAY	SY	485.0	1,283.0	\$ 15.00	\$ 19,245.00
24	BITUMINOUS MATERIAL FOR TACK COAT	GAL	700.0	5.0	\$ 1.25	\$ 6.25
25	12 CMP CULVERT INCL END APRON	LF	36.0	30.0	\$ 28.25	\$ 787.50
26	12" RC PIPE SEWER CLASS V DESIGN 3006	LF	296.0	370.0	\$ 42.00	\$ 15,540.00
27	15" RC PIPE SEWER CLASS V DESIGN 3008	LF	135.0	603.0	\$ 33.60	\$ 20,260.80
28	18" RC PIPE SEWER CLASS V DESIGN 3006	LF	32.0	71.0	\$ 52.50	\$ 3,727.50
29	12" RC PIPE APRON	EA	7.0	11.0	\$ 525.00	\$ 5,775.00
30	18" RC PIPE APRON	EA	3.0	4.0	\$ 658.00	\$ 2,624.00
31	CONSTRUCT CATCH BASIN DESIGN 4021D	EA	8.0	12.0	\$ 1,680.00	\$ 20,160.00
32	CONSTRUCT SURFACE DRAIN 24"	EA	1.0	1.0	\$ 787.50	\$ 787.50
33	CONSTRUCT STORM SEWER MH DESIGN 48"	EA	3.0	1.0	\$ 1,575.00	\$ 1,575.00
34	D412 CONCRETE CURB AND GUTTER	LF	300.0	250.0	\$ 12.60	\$ 3,150.00
35	6" BITUMINOUS CURB	LF	150.0	83.0	\$ 8.00	\$ 664.00
36	INSTALL SALVAGED STEELPLATE BEAM GUARD RAIL- INCLUDING NEW POSTS AS NECESSARY	LF	100.0	87.2	\$ 17.80	\$ 1,552.16
37	INSTALL TWISTED END TREATMENT	EA	2.0	2.0	\$ 1,417.50	\$ 2,835.00
38	6" CONCRETE DRIVEWAY PAVEMENT	SY	103.0	80.18	\$ 50.40	\$ 4,545.07
39	FLAG PERSON	HR	40.0	69.0	\$ 65.00	\$ 4,485.00
40	4" DOUBLE SOLID LINE YELLOW-PAINT	LF	2,000.0	-	\$ 0.75	\$ -
41	INLET PROTECTION AT CB	EA	10.0	11.0	\$ 135.00	\$ 1,485.00
42	SEEDING COMPLETE WITH TYPE 26B SEED MIXTURE	SY	800.0	4,350.0	\$ 0.90	\$ 3,915.00
43	WOOD FIBER BLANKET TYPE II	SY	800.0	4,350.0	\$ 1.80	\$ 7,830.00
44	SODDING TYPE 1	SY	2,000.0	2,227.0	\$ 2.80	\$ 6,235.60
SUBTOTAL ESTIMATE NO. 2						\$ 413,682.94
CHANGE ORDER NO. 1						
1	FURNISH AND INSTALL RIP RAP	CY		12.0	\$ 38.33	\$ 459.96
2	FURNISH, INSTALL, AND MAINTAIN SILT FENCE	LF		750.0	\$ 1.96	\$ 1,470.00
3	FURNISH AND INSTALL 6" PVC CULVERT	LF		32.0	\$ 26.63	\$ 852.16
4	FURNISH AND INSTALL DIAMOND BLOCK RETAINING WALL	LS		1.0	\$ 1,207.90	\$ 1,207.90
5	ADDITIONAL COST ABOVE UNIT PRICES TO INSTALL STORM SEWER WORK ALONG 50TH STREET	LS		1.0	\$ 6,474.85	\$ 6,474.85
TOTAL CHANGE ORDER NO. 1						\$ 10,464.87
TOTAL ESTIMATE NO. 4						\$ 424,147.21

<p>Lake Elmo City Council 09-07-2004</p>	<p>Agenda Section: Finance</p>	<p><u>No. 5A</u></p>
<p><u>Agenda Item:</u> Adoption of Proposed Levy Limit</p>		
<p><u>Background Information for September 07, 2004:</u></p> <p>Attached, Please find Resolution 2004-75 pertaining to the adoption of the proposed 2004 Tax Levy, collectible 2005 in the amount of \$ <u>1,923,989</u>. After the Budget Workshop conducted on August 31, 2004 with the full Council in attendance and a review conducted by the Finance & Judicial Council Committee, the recommended adjustments have been completed and the proposed Levy has been approved. Please note; the proposed amount certified to the County by September 15, 2004 cannot be increased however, the City does retain the authority to lower the Levy.</p>		
<p><u>Action Items:</u> Motion to Adopt Resolution No. 2004-75 for the Proposed 2004 Tax Levy, collectible in 2005.</p>		<p><u>Person responsible:</u> Tom Bouthilet</p>
<p><u>Attachments:</u> Resolution 2004-75</p>		

CITY OF LAKE ELMO
WASHINGTON COUNTY, MINNESOTA

RESOLUTION NO. 2003-075
RESOLUTION APPROVING PROPOSED 2004 TAX LEVY, COLLECTIBLE IN 2005

BE IT RESOLVED by the Council of the City of Lake Elmo, County of Washington, Minnesota that the following proposed sums of money be levied for the current year, collectible in 2005, upon taxable property in the City of Lake Elmo, for the following purposes:

Total Levy \$ 1,923,989

BE IT RESOLVED that the City Clerk is hereby instructed to transmit a certified copy of this resolution to the County Auditor of Washington County, Minnesota.

ADOPTED, by the Lake Elmo City Council on the 7th day of September, 2004.

Lee Hunt
Mayor

ATTEST:

Martin Rafferty
City Administrator

Lake Elmo City Council 09-07-2004	Agenda Section: Finance	<u>No . 5B</u>
<u>Agenda Item: Set Truth n' Taxation Hearing Dates</u>		
<u>Background Information for September 07, 2004:</u> <p>The City conducts a Truth in Taxation Public Hearing for the 2005 General Fund Budget and the final 2004 Tax Levy, collectible in 2005. The time frame for these Hearing Date is between November 29th and December 20th and cannot be conducted on the same dates the County, School District and any other Special Taxing District holds there hearings. Due to the limited available dates, I suggest that the Council consider Monday December 6th at 7:00pm and a Continuation Hearing (if necessary) on Monday December 13th at 5:30 for the Truth in Taxation Public Hearings.</p>		
<u>Action Items:</u> Motion to Adopt Resolution No. 2004-76 setting the Truth in Taxation Public Hearing dates for the 2004 Tax Levy and the 2005 Budget.		<u>Person responsible:</u> Tom Bouthilet
<u>Attachments:</u> Resolution 2004-76		

**CITY OF LAKE ELMO
WASHINGTON COUNTY, MINNESOTA**

RESOLUTION NO. 2004-076

**A RESOLUTION SETTING THE TRUTH IN TAXATION
PUBLIC HEARING DATES FOR 2004 TAX LEVY**

WHEREAS, the City is required to set public hearing dates for the truth in taxation hearing on the 2005 budget and tax levy; and

WHEREAS, these dates cannot conflict with those dates for school districts within the City of Lake Elmo or Washington County; and

WHEREAS, the City needs to set dates for the initial truth in taxation hearing date, and a proposed continuation hearing date should one be necessary.

NOW, THEREFORE, BE IT HEREBY RESOLVED, that the City of Lake Elmo has set December 6, 2004 at 7:00 p.m. as the initial truth in taxation public hearing date and December 13, 2004 at 5:30 p.m. as the continuation date for the truth and taxation public hearing, if necessary, and the final adoption of the levy and budget.

ADOPTED, by the Lake Elmo City Council on the 7th day of September, 2004.

Lee Hunt, Mayor

ATTEST:

Martin Rafferty,
City Administrator

<p>Lake Elmo City Council September 7, 2004</p>	<p>Agenda Section: CITY ENGINEER' S REPORT</p>	<p><u>No 8A.</u></p>
<p><u>Agenda Item:</u> Hill Trail Assessment Appeal, Resolution No. 2004-069, Adopting Assessment for the Reconstruction of Hill Trail North and 50th Street North.</p>		
<p><u>Background Information for September 7, 2004</u> At the August 17th meeting, the Council tabled adoption of the assessment for the Reconstruction of Hill Trail/50th Street to allow the City Engineer and City Attorney to review the appeal of Roger Johnson and address the concerns stated in Bud Talcott's memo. Attached are the Engineer's recommendations and the response to Talcott's memo of August 17, 2004.</p> <p>The City Engineer recommends the adoption of Resolution 2004-069 adopting the assessment roll as amended.</p>		
<p><u>Action Items:</u> Motion/Second - to adopt Resolution No. 2004-069 Adopting the Assessment roll, as amended (deleting parcels 04-029-21-33-0041 and 04-029-21-33-0030 adjacent to Roger Johnson's home) for the Reconstruction of Hill Trail N. and 50th Street N., verified by the City Engineer's memo dated September 1, 2004.</p>	<p><u>Person responsible:</u> T.Prew</p>	

TKDA

ENGINEERS • ARCHITECTS • PLANNERS

1500 Piper Jaffray Plaza
444 Cedar Street
Saint Paul, MN 55101-2140(651) 292-4400
(651) 292-0083 Fax
www.tkda.com**MEMORANDUM**

To: Lake Elmo City Council
Copies To: _____

From: Thomas D. Prew, P.E. *TP*
Date: September 1, 2004

Reference: Hill Trail Assessment Appeal
Parcels 05-29-21-33-024 and -026
City of Lake Elmo, Minnesota
Comm. No. 12170-03
Routing: _____

As shown on the attached sheets, Parcels 05-29-21-33-024 and 05-29-21-33-026 are in the interior area of the loop road of Hill Trail. These lots are combined and have frontage on an unimproved street right-of-way.

We recommend these parcels be assessed, as they gain access from 50th Street North. There are a number of other properties on this project that have a similar situation and are being assessed.

Maps are attached.

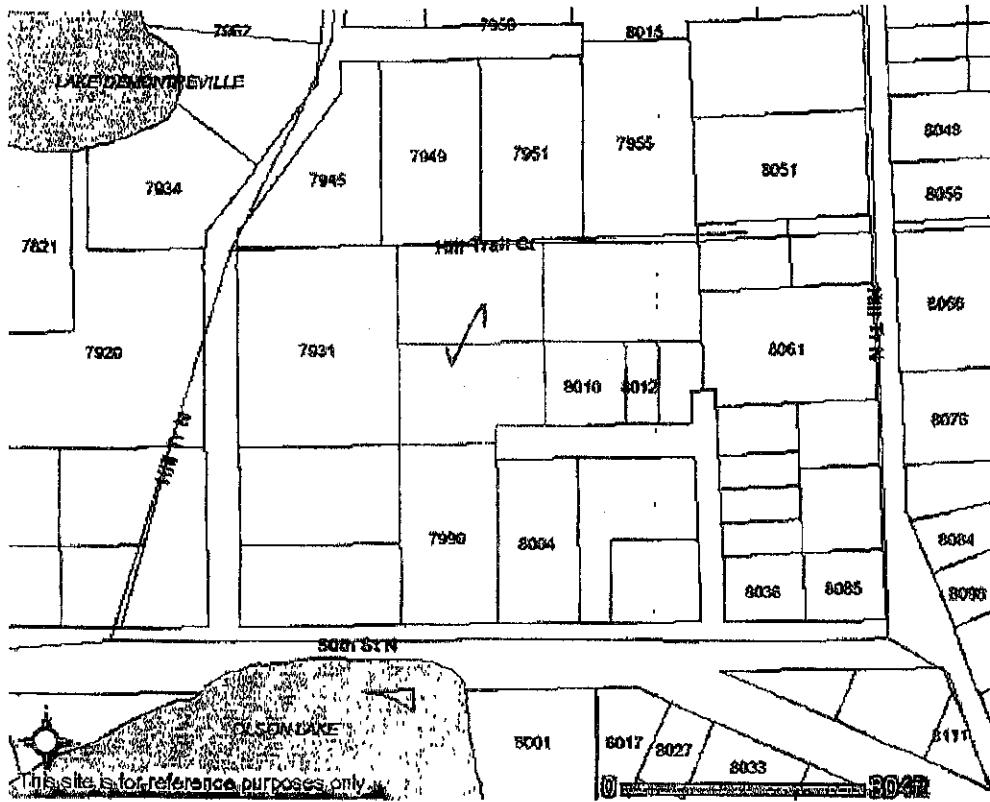

05-29-21-33-0024
ROETER JOHNSON

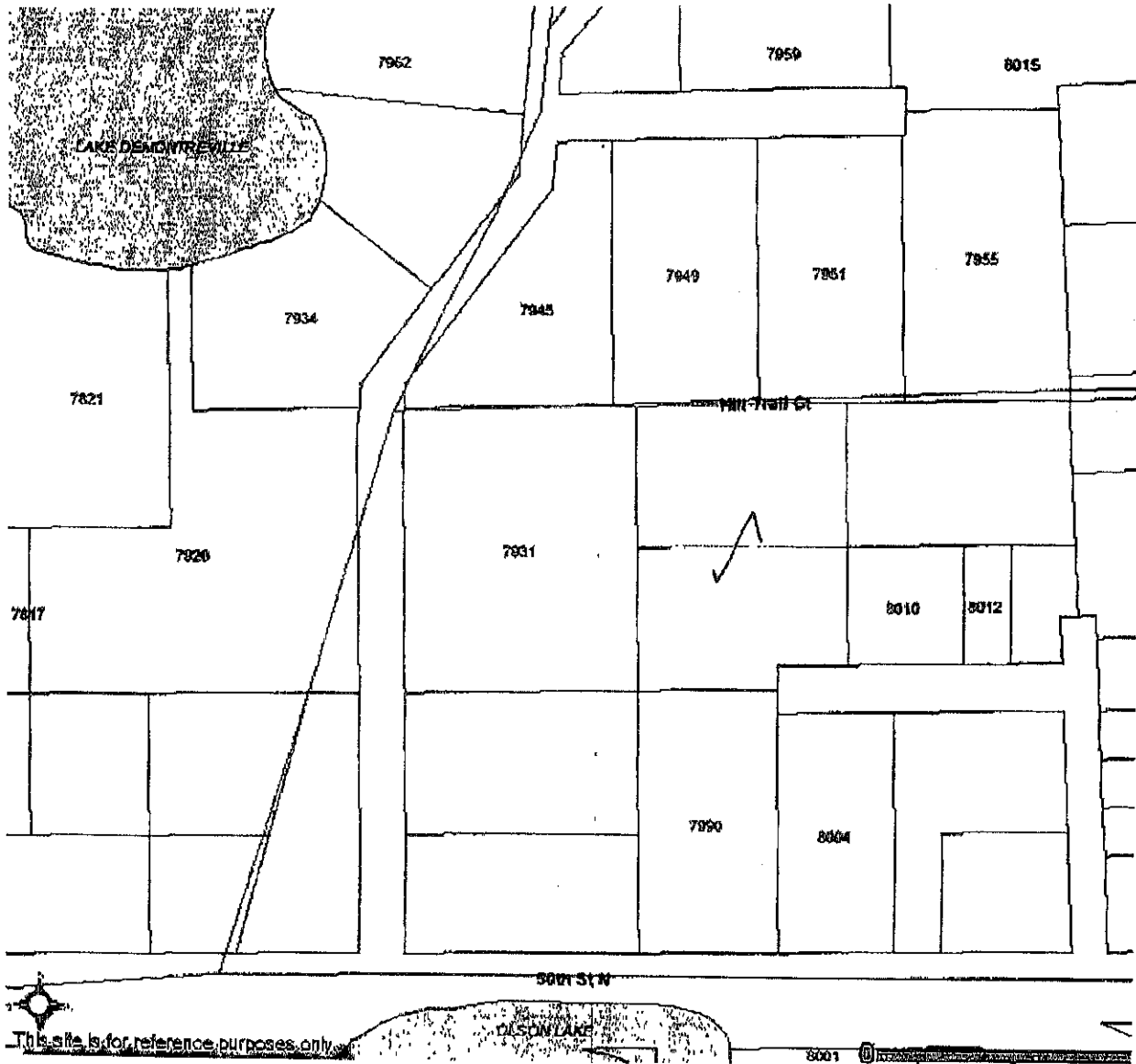

05-29-21-33-0026

ROGER JOHNSON.

RECEIVED

AUG 1 / 2004

City Council of Lake Elmo

City of Lake Elmo
3800 Laverne Avenue North
Lake Elmo, MN 55042

Re: Hill Trail Street Assessment
Notice of Objection for
Parcel 04.029.21.33.0024-ect
05 0026

Dear Mayor Hunt and Council representatives,

I recently received notice that the above listed parcel is proposed to be assessed for the Hill Trail Reconstruction Project.

This note is to let you know that I object to the assessment because:

1. The parcel does not abut Hill Trail.
2. There is no road constructed into this property.
3. The value of this property has not been enhanced by the Hill Trail Reconstruction project.

Thanks in advance for your consideration. If you have any questions or require additional information, please let me know.

Sincerely,

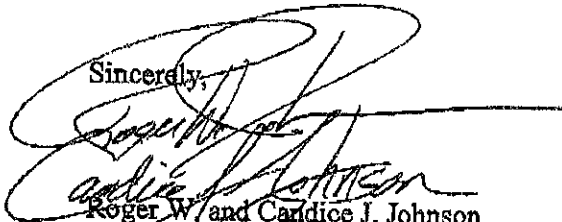

Roger W. and Cardice J. Johnson
8046 Hill Trail North
Lake Elmo, MN 55042

TKDA

ENGINEERS - ARCHITECTS - PLANNERS

1500 Piper Jaffray Plaza
444 Cedar Street
Saint Paul, MN 55101-2140

(651) 292-4400
(651) 292-0083 Fax
www.tkda.com

MEMORANDUM

To: Lake Elmo City Council

Reference: Hill Trail Assessment Appeal

Copies To: _____

Parcels 04-029-21-33-041 and -030

City of Lake Elmo, Minnesota

From: Thomas D. Prew, P.E. *TP*

Comm. No. 12170-03

Date: September 1, 2004

Routing: _____

As shown on the attached sheets, Parcels 04-029-21-33-041 and 04-029-21-33-0030 are adjacent to Mr. Johnson's current home. These properties will be, or have already been, combined.

We recommend these parcels not be assessed, as they are small and will be combined with another parcel that is being assessed.

Maps are attached.

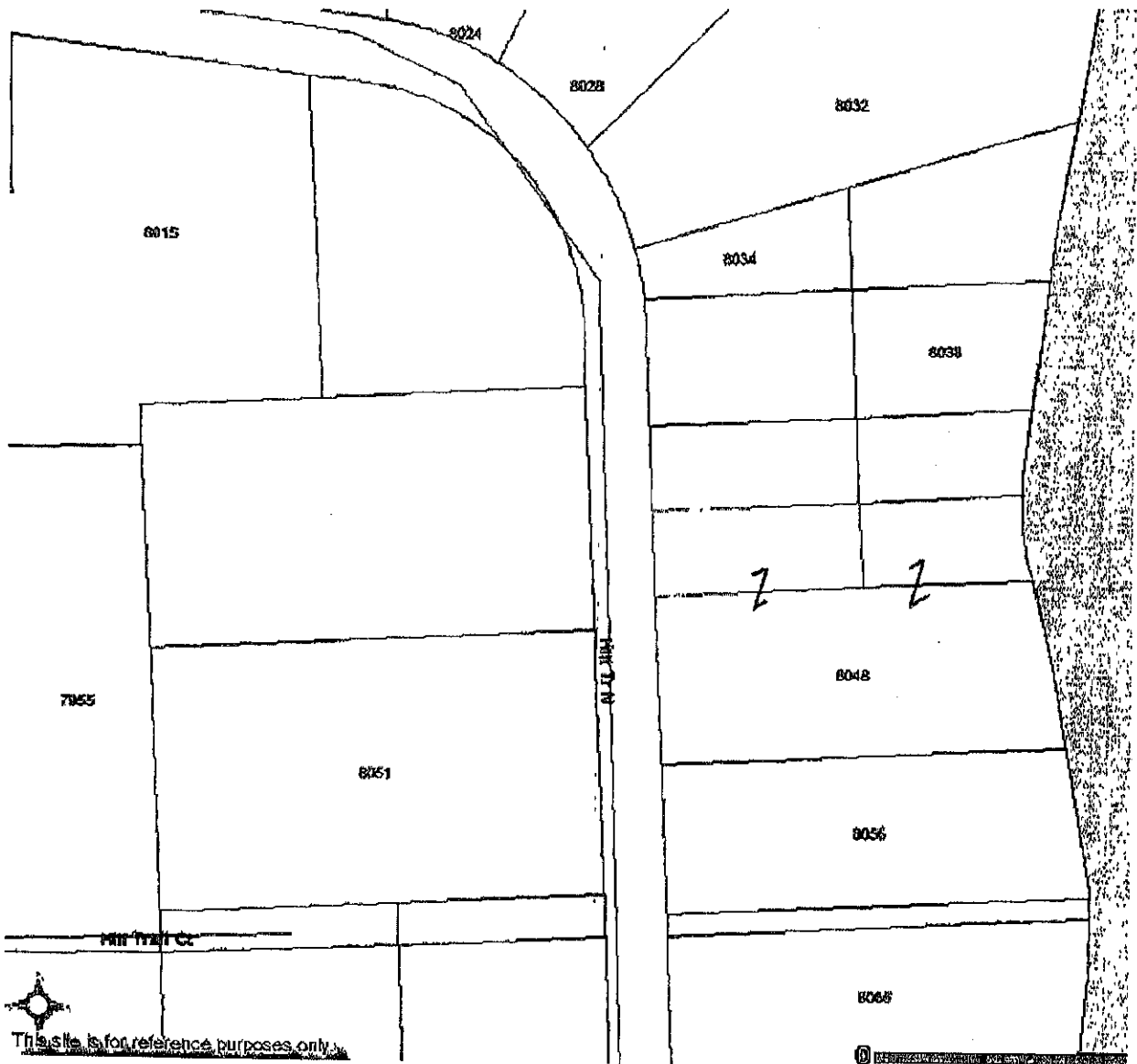

04-029-21-33-0030
ROGER JOHNSON

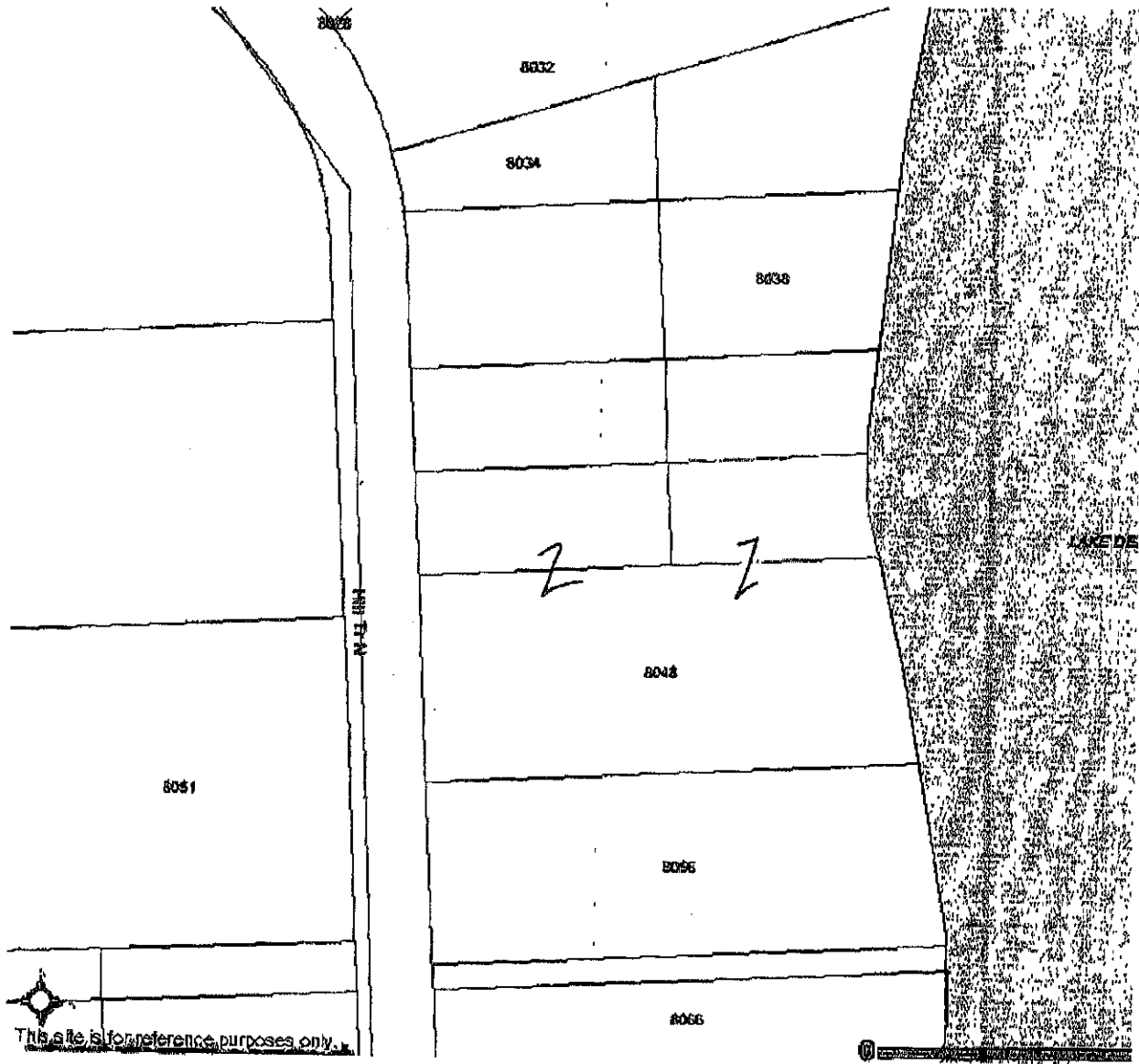

04-029-21-33-0041
ROGER JOHNSON.

RECEIVED

AUG 17 2004

OA.

City Council of Lake Elmo

City of Lake Elmo
3800 Laverne Avenue North
Lake Elmo, MN 55042

Re: Hill Trail Street Assessment
Notice of Objection for
Parcel 04.029.21.33.00~~2~~₁ and 04.029.21.33.0030
4

Dear Mayor Hunt and Council representatives,

My home, is situated on a single-family lot, comprised of the above listed parcels. These parcels were combined as a condition of my purchase of parcel 04.029.21.33.0030 last spring. I recently received notice that each parcel is assessed separately for Hill Trail Reconstruction. This note is to let you know that I object to the two assessments for my homesteaded property and would appreciate your reducing it to a single assessment. I also object to the amount of the assessment as the value of my property has not been enhanced by the reconstruction project.

Thanks in advance for your consideration. If you have any questions or require additional information, please let me know.

Sincerely,

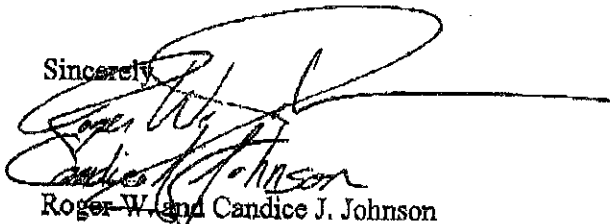

Roger W. and Candice J. Johnson
8048 Hill Trail North
Lake Elmo, MN 55042

TKDA

ENGINEERS • ARCHITECTS • PLANNERS

1500 Piper Jaffray Plaza
444 Cedar Street
Saint Paul, MN 55101-2140

(651) 292-4400
(651) 292-0083 Fax
www.tkda.com

September 1, 2004

Honorable Mayor and City Council
City of Lake Elmo, Minnesota

Re: Response to Talcott Memo
Hill Trail and 50th Street Reconstruction
City of Lake Elmo, Minnesota
TKDA Commission No. 12170-03

Dear Mayor and City Council:

As requested, I have prepared a reply to the questions in Mr. Talcott's memo of August 17, 2004.

Project Objective

The purpose of this project was to reconstruct the streets in this neighborhood. An added benefit of reconstructing the streets, instead of overlaying them, was the ability to address many drainage issues.

Road Elevation

Preliminary plans were developed and presented with the Feasibility Report. Those preliminary street grades were closely followed through final design and construction. Some areas were lowered and some grades were raised. The street was laid out to match existing driveways and yards as closely as possible.

The City has not experienced problems with bituminous curbs breaking down.

Water Holding Areas

Construction of the small stormwater pond on the City property which also holds a City-owned mound system was presented to the City Council in the Feasibility Report. That property was never, to my knowledge, envisioned to be a septic system area. The soils would not have supported a drainfield system, and a mound would have needed to be very small.

Honorable Mayor and City Council
City of Lake Elmo
September 1, 2004
Page 2

Storm Drains

The catch basins installed are not the City standard. They were chosen because of past problems with leaves covering and blocking the grated catch basins in this neighborhood. The Public Works foreman reviewed and approved this design. They have used them in other areas of the City.

The Contractor will be re-sodding and adjusting the bituminous curb around the catch basins so they will blend in better.

Grading and Sodding

Small areas of dead sod will be replaced. I will check to make sure there is sufficient topsoil under them. I believe most areas of sod died because they were not watered during the drier periods of the summer.

The Contractor has used a metal locator to find and remove turf staples. We will continue to watch for turf staples as we are completing work in the neighborhood.

Sincerely,



Thomas D. Prew, P.E.
City Engineer

TDP:jls

CITY OF LAKE ELMO
WASHINGTON COUNTY, MINNESOTA

RESOLUTION NO. 2004-069
A RESOLUTION ADOPTING ASSESSMENT FOR THE RECONSTRUCTION OF
HILL TRAIL NORTH AND 50TH STREET NORTH

WHEREAS, pursuant to proper notice duly given as required by law, the Council has met and heard and passed upon all objections to the proposed assessment for the improvement of Hill Trail North and 50th Street North in Lake Elmo, Minnesota.

NOW, THEREFORE, BE IT RESOLVED BY THE CITY COUNCIL OF LAKE ELMO, MINNESOTA:

1. Such proposed assessment, a copy of which is attached hereto and made a part hereof, is hereby accepted and shall constitute the special assessment against the lands named therein, and each tract of land therein included is hereby found to be benefited by the proposed improvement in the amount of the assessment levied against it.
2. Such assessment shall be payable in equal annual installments extending over a period of ten (10) years, the first of the installments to be payable on or before the first Monday in January, 2005, and shall bear interest at the rate of 5.75 percent per annum from the date of the adoption of this assessment resolution. To the first installment shall be added interest on the entire assessment from the date of this resolution until December 31, 2001. To each subsequent installment when due shall be added interest for one year on all unpaid installments.
3. The owner of any property so assessed may, at any time prior to certification of the assessment to the County Auditor, pay the whole of the assessment on such property, with interest accrued to the date of payment, to the City of Lake Elmo, except that no interest shall be charged if the entire assessment is paid within 30 days from the adoption of this resolution; and he may, at any time thereafter, pay to the City of Lake Elmo the entire amount of the assessment remaining unpaid, with interest accrued to December 31 of the year in which such payment is made. Such payment must be made before November 15 or interest will be charged through December 31 of the succeeding year.
4. The Finance Director shall forthwith transmit a certified duplicate of this assessment to the County Auditor to be extended on the property tax lists of the county. Such assessments shall be collected and paid over in the same manner as other municipal taxes.

ADOPTED by the Lake Elmo City Council on the 7th day of September, 2004.

Lee Hunt, Mayor

ATTEST:

Sharon Lumby, City Clerk

Lake Elmo City Council September 7, 2004	Agenda Section: CITY ENGINEER'S REPORT	<u>No 8B.</u>
<u>Agenda Item:</u> Speed Study Results for Highlands Trail		
<u>Background Information for September 7, 2004</u> Per the request of the Council, a 48-hour speed study was done on Highlands Trail. In his memo dated September 2, 2004 the City Engineer reported the speed study was done west of Highlands Court. The results of the study show that two thirds of the vehicles travel between 31 and 40 MPH. The posted speed limit is 30 MPH. In order to reduce the traffic speed, he recommends narrowing the street from 59 th Street to Hytrail Avenue to 26 feet which would eliminate on-street parking.		
<u>Action Items:</u> The City Engineer requests Council direction.	<u>Person responsible:</u> T.Prew	

TKDA

ENGINEERS - ARCHITECTS - PLANNERS

1500 Piper Jaffray Plaza
444 Cedar Street
Saint Paul, MN 55101-2140(651) 292-4400
(651) 292-0088 Fax
www.tkda.com

September 2, 2004

Honorable Mayor and City Council
City of Lake Elmo, MinnesotaRe: Speed Study Results
Highlands Trail
City of Lake Elmo, Minnesota
TKDA Commission No. 11979-041

Dear Mayor and City Council:

As requested, a 48-hour Speed Study was done on Highlands Trail. The Speed Study was done west of Highlands Court, which should be where the highest rate of speed is assumed to be. Results of the Speed Study are listed in the table below:

	West Bound	East Bound	Total
Vehicles Per Day	457	400	857
Mean Speed (MPH)	34	33	33
85th Percentile Speed (MPH)	39	39	39
Vehicles > 35 MPH	38.7%	36.3%	37.5%

The results are not too surprising. Two-thirds of the vehicles travel between 31 and 40 MPH. However, the posted speed limit is 30 MPH.

In order to reduce the overall traffic speed, we would recommend narrowing the street from 59th Street to Hytrail Avenue to 26 feet. This would eliminate on-street parking unless parking bays were built. A trail may also be necessary, as narrowing the street would reduce the area for pedestrians.

We do not believe that only widening at the intersections will reduce the overall speed of the traffic. A median would be difficult to install with the large number of driveways present.

Sincerely;

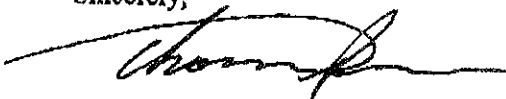
Thomas D. Prew, P. E.
City Engineer

TDP:mrk

Lake Elmo City Council September 7, 2004	Agenda Section: CITY ENGINEER'S REPORT	<u>No 8C.</u>
<u>Agenda Item: 45th Street Pond</u>		
<u>Background Information for September 7, 2004</u> In his memo dated September 2, 2004 the City Engineer reported he received two quotes for repair of an erosion problem on City owned property on 45 th Street. The quotes received were from Miller Excavating for \$11,665.00 and Larson Contracting for \$17,900.00. The City Engineer recommends accepting the quote from Miller Excavation for construction of the 45th Street Pond.		
<u>Action Items:</u> Motion/Second – to accept the quote from Miller Excavating for \$11,665.00 for construction of the 45 th Street Pond, per the recommendation of the City Engineer in his memo dated September 2, 2004.	<u>Person responsible:</u> T.Prew	

TKDA

ENGINEERS • ARCHITECTS • PLANNERS

1500 Piper Jaffray Plaza
444 Cedar Street
Saint Paul, MN 55101-2140

(651) 292-4400
(651) 292-0083 Fax
www.tkda.com

September 2, 2004

Honorable Mayor and City Council
City of Lake Elmo, Minnesota

Re: 45th Street Pond
City of Lake Elmo, Minnesota
TKDA Commission No. 11979-041

Dear Mayor and City Council;

We have received 2 quotes for repair of an erosion problem on the City owned property on 45th Street. I have attached a 1996 TKDA letter which describes the problem.

Last fall the City graded this area to stop runoff from reaching the slope; however this caused an icing problem on 45th Street last spring. This project will create a pond, and pipe the water across 45th Street.

The quotes received were from Miller Excavating for \$11,665.00 and Larson Contracting for \$17,900.00.

City Council Action Requested

Accept the quote from Miller Excavating for \$11,665.00 for construction of the 45th Street pond.

Sincerely,



Thomas D. Prew, P. E.
City Engineer

Attachments



MILLER EXCAVATING, INC.

"PETE" MILLER

"Big or Small, We Do Them All!"

(651) 439-1637 Fax (651) 439-1637

email: pmillerexc@aol.com
www.millerexc.com

3636 Stagecoach Trail No.
Stillwater, Minnesota 55082

August 16, 2004

Attn.: Tom Prew, P.E.
City of Lake Elmo
3800 Laverne Ave. N.
Lake Elmo, MN 55042

Fax: 651-292-0083
Phone: 651-292-4463

Project: 45th St. pond

1. Saw cut existing asphalt
2. Remove asphalt for new pipe across road
3. Grade new ponding area with material on site
4. Install new 24" catch basin with drilled holes, per specs. dated 6/29/04
5. Install new 12" CPP approx. 100 ft.
6. Install new 12" flared end section without grate
7. Install rip rap outlet at flared end section
8. Install rip rap inlet at catch basin
9. Install Neenah R-4342 casting
10. Blacktop flume from street to pond
11. Patch street in two 2" lifts of asphalt with 6" gravel base
12. Install fiber blanket in pond area
13. Seed pond area with mix 26B
14. Flagmen to be used during street work

Bid Price \$11,665.00

NOTES

- * No tree removal
- * No sign removal
- * No fence removal
- * No silt fence necessary
- * Surveying by engineer
- * Topsoil from adjacent field
- * Site material to balance
- * No striping necessary
- * All work per plan dated 6/29/04

Steve St. Claire
Steve St. Claire
Miller Excavating, Inc.

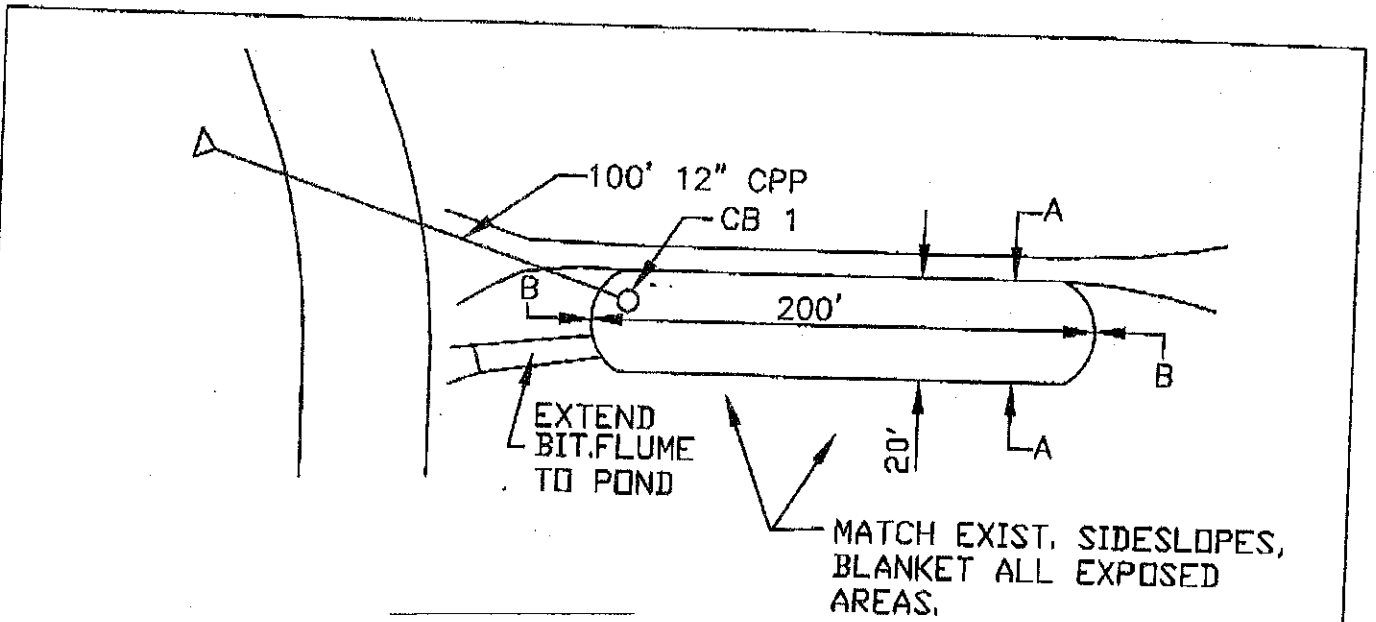

A-A

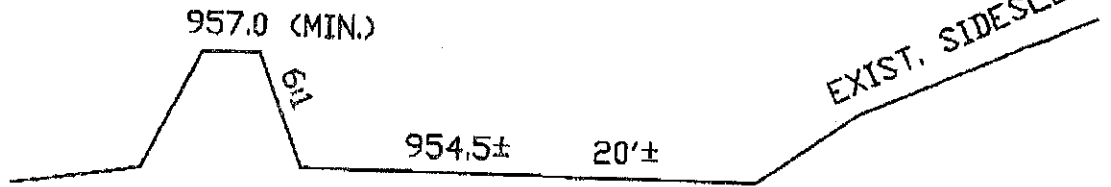

B-B

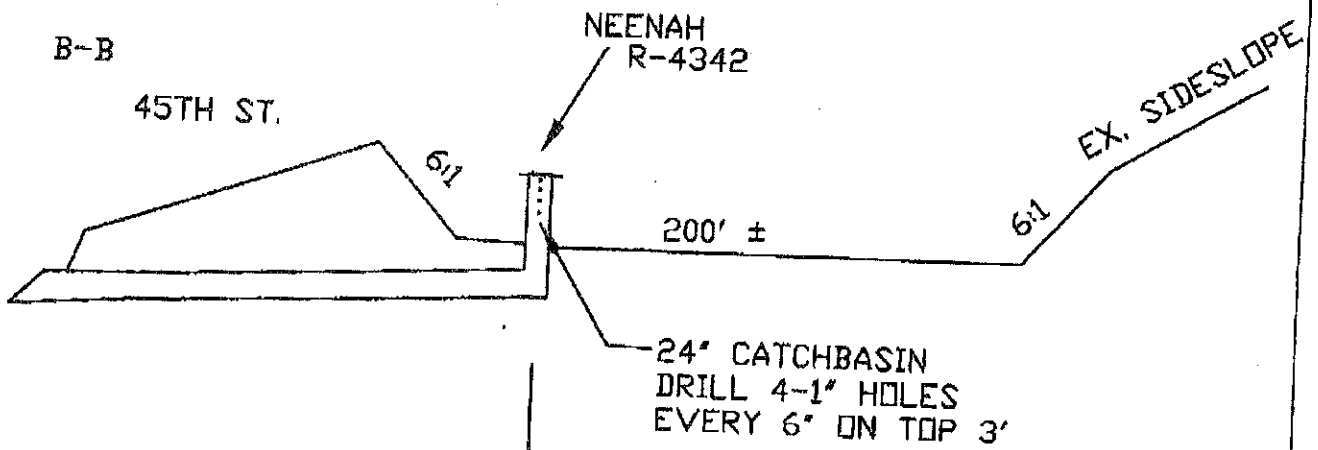

RIM 956.5
INV 950.0

DATE 06/10/04
MAP NUMBER 42710 85.dwg

TKDA

COMM. NO. 11979-041
LAKE ELMO, MINNESOTA

45TH STREET AND POND

1. BALANCE EXISTING MATERIAL ON SITE. ADJUST GRADES AS NECESSARY.
2. PLACE FIBER BLANKET AND USE SEED MIX 26B. (AFTER SEPT. 10)
3. PROVIDE FLAGGER DURING ALL STREET WORK.

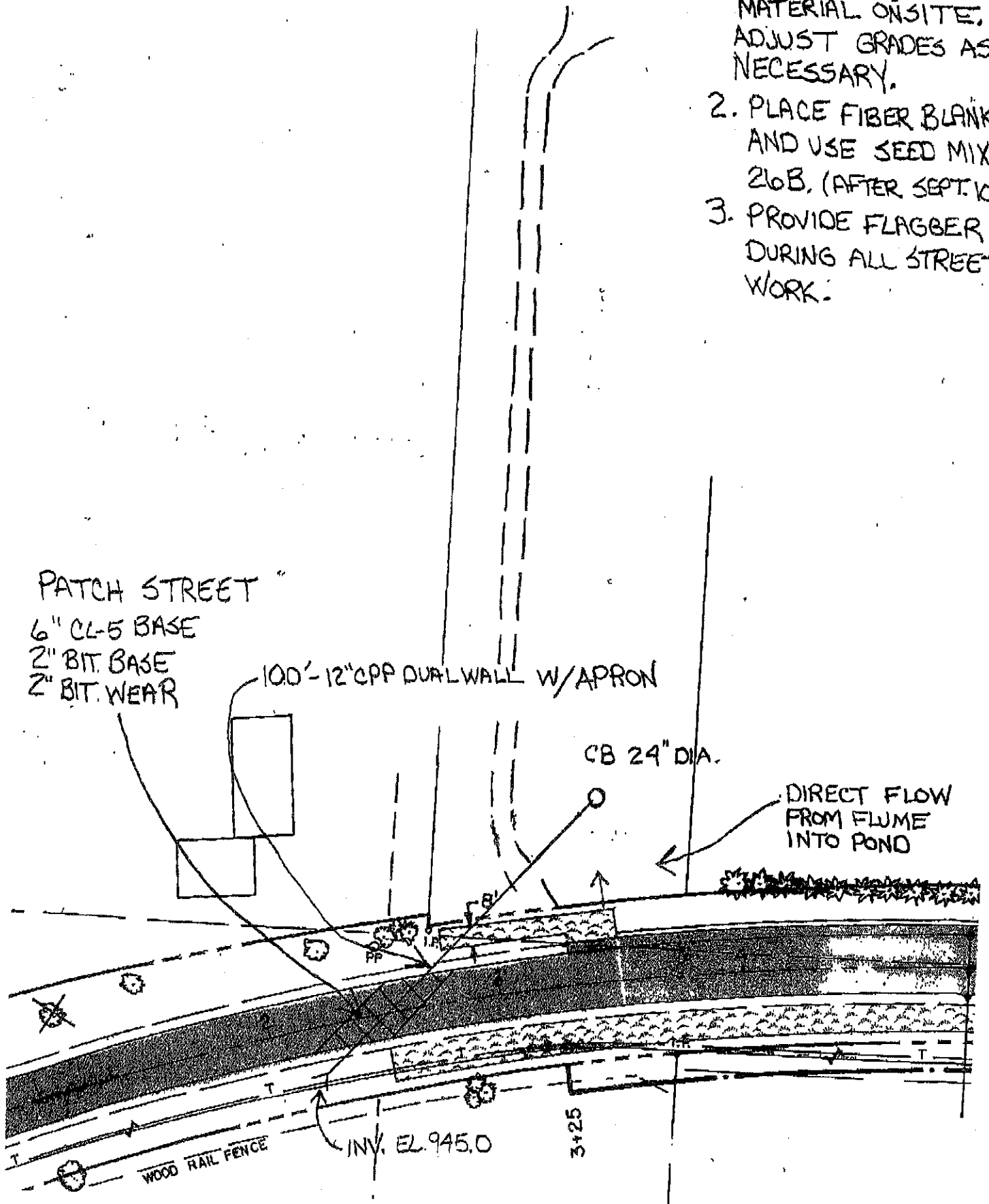

PATCH STREET "

6" CL-5 BASE
2" BIT. BASE
2" BIT. WEAR

100'-12" CPP DUAL WALL W/APRON

CB 24" DIA.

DIRECT FLOW FROM FLUME INTO POND

WOOD RAIL FENCE

INV. EL. 945.0

3+25

TKDA

ENGINEERS • ARCHITECTS • PLANNERS

TOLTZ, KING, DUVALL, ANDERSON
AND ASSOCIATES, INCORPORATED

1500 PIPER JAFFRAY PLAZA
444 CEDAR STREET
SAINT PAUL, MINNESOTA 55101-2140
PHONE: 612/292-4400 FAX: 612/282-0083

February 2, 1996

Honorable Mayor and City Council
Lake Elmo, Minnesota

Re: Drainage Concern at
Lake Jane Trail and Jane Road
Lake Elmo, Minnesota
Commission No. 9150-960

Dear Council Members:

At the rezoning hearing for the proposed Public Works facility, residents on Jane Road complained about a drainage problem that had been alleged to have been going on since 45th Street was constructed in 1984. The properties and owners alleged to be affected are James Friend at 9498 Jane Road and Pano Petrellis at 9436 Jane Road. The Council directed the Engineer to investigate the situation.

Background

In 1984, the City awarded a construction contract to Forest Lake Contracting for the reconstruction of 45th Street, Julep Avenue, and 47th Street from Jane Road to Keats Avenue. The contract called for a certain amount of fill soil to be furnished by the contractor. The contractor negotiated with John Berschens to obtain this soil from the powerline easement which was owned by Berschens but wasn't being tilled. This area is west of the Friend and Petrellis property and at a higher elevation. It is my recollection that no property east of the powerline was disturbed.

Analysis

Since we could not determine where the drainage breaks were by eye, we took some elevation shots on the Berschens property. The attached diagram shows that about 3 acres of Berschens property drains west while the remainder drains east. It is also interesting that the west edge of the powerline easement is about 10' - 15' lower than the east edge of the powerline easement. The land slopes gradually to the south but more steeply to the west.

Friend owns Lot 1 and the south 1/2 of Lot 2. Petrellis owns Lot 3 and the north 1/2 of Lot 2. The drainage runs west toward Lake Jane on the common line between these two properties. The property owners are concerned about erosion and that the drainage may affect a septic system.

Solution

Since the land gradually slopes to the south, a berm could be constructed on the west line of the powerline easement to direct the runoff to the 45th Street road ditch. The water would then run along the south line of Friend's lot to Jane Road. I believe a berm was constructed by Forest Lake Contracting in 1984 but may have since been overtopped and eroded through. I will be meeting with the property owners Monday afternoon so I will have a report at the Council meeting. If the Berschen's site were selected for the new Public Works facility, this berm could

Honorable Mayor and City Council
February 2, 1996
Page 2

be incorporated into the other site grading work to be done on the site. If the site is not chosen, the City will have to determine if it has any responsibility for regrading if erosion has since occurred.

Sincerely,



Larry D. Bohrer, P.E.

LDB/mha
Enclosure

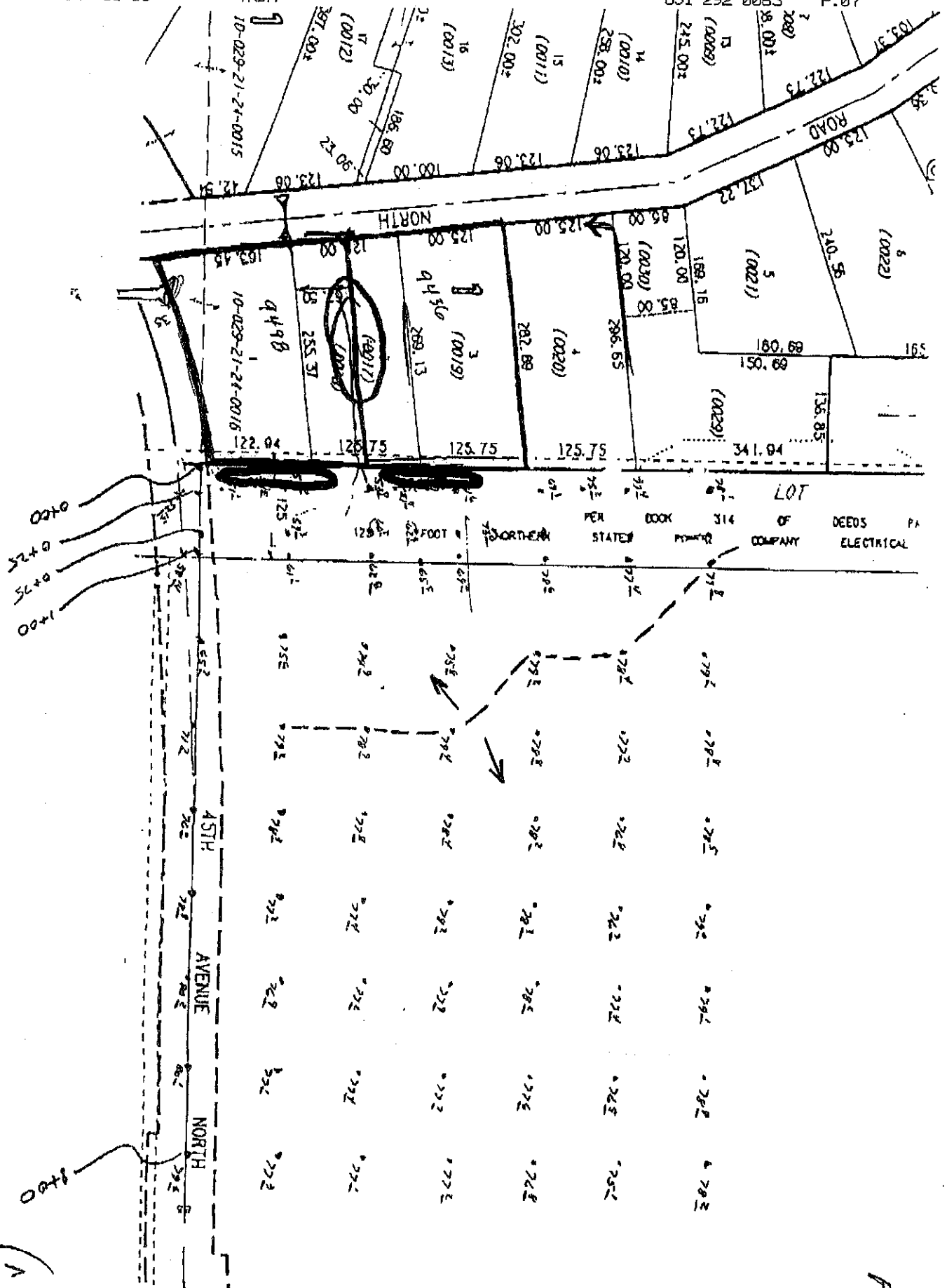

Lake Elmo
City Council
September 7,
2004

Agenda Section: Planning, Land Use & Zoning

No. 9A

Agenda Item: Zoning Ordinance Amendment – Family Entertainment Center

Background Information for September 7, 2004:

As earlier suggested by the City Council the Planning Commission did, at their August 23 meeting, again consider a Zoning Ordinance text amendment regarding the addition of Family Entertainment Center (FEC) as an allowable use. Staff had published a Notice of Public Hearing in a timely manner to consider an amendment to the General Business (GB) zoning district text to allow a Family Entertainment Center (without building area limitation) in the GB zone as a Conditional Use. Following the Hearing (no testimony presented) the Commission adopted a Motion (5-3, Helwig, Johnson and Schneider opposed) to recommend amendment to the GB zone as proposed (as a Conditional Use) and the addition of "Family Entertainment Center" to the Definition Section – one Motion. The recommendation modifies the FEC definition to remove "indoor paintball" as a specific inclusion. The

All three nay votes on the Motion specifically related to the exclusion of "indoor paintball" as a stated component of Family Entertainment Center in the definition. Those commissioners all stated that they believed that the decision as to whether participation in "indoor paintball" was appropriate should be that of the individual (parent) rather than the City.

Attached are draft ordinances to amend the City Code as recommended by the Commission.

Action items:

1. Motion to adopt Ordinance #97-¹³⁸ amending the General Business District zoning ordinance text to include Family Entertainment Center as a Conditional Use.
2. Motion to adopt Ordinance #97 -¹³⁹, adding a definition of "Family Entertainment Center to the City Code

Person responsible:

City Planner

Attachments:

1. Draft Ordinance #97 - Amending General Business
2. Draft Ordinance #97 – Amending Definitions
3. Draft Planning Commission Minutes of August 23
4. City Council Minutes of August 4, 2004

Time Allocated:

CITY OF LAKE ELMO
WASHINGTON COUNTY, MINNESOTA

ORDINANCE 97 - 138

AN ORDINANCE AMENDING SECTION 307.07 SUBDIVISION 4.K.3. AND 4.
RELATING TO CONDITIONAL USES IN THE GENERAL BUSINESS
ZONING DISTRICT

Section 1. Amendment: Section 307.07, Subdivision 4.H.1.e. of the Lake Elmo Municipal Code is hereby amended to read as follow, to wit:

e. Uses Permitted by Conditional Use Permit: (Amended Ordinance 97-20 on 10-21-97)

General Business	
Bed and Breakfast Facility	15 Beds Maximum
Boarding Care Facility	15 Residents Maximum
Day Care Centers	40 Children Maximum
Family Entertainment Centers	
Kennels	
Nursing Care Facility	15 Residents Maximum
Open Sales Lots	
Manufacturing	Any industrial manufacturing operation in existence within the City at the effective date of this section, including manufacture of wood products and plastic products, may continue the use as a conforming use without a conditional use permit. Nothing in this provision shall otherwise be construed to require the City to authorize any manufacturing use in the general business zone after the effective date of this section.
Veterinary Clinics	

Section 2. Effective Date: This ordinance shall become effective upon its passage and publication according to law.

ADOPTED by the Lake Elmo City Council this day of 2004.

Lee Hunt, Mayor

ATTEST:

Martin Rafferty, City Administrator

CITY OF LAKE ELMO
WASHINGTON COUNTY, MINNESOTA

ORDINANCE NO. 97-0139

AN ORDINANCE AMENDING SECTION 150
OF THE LAKE ELMO MUNICIPAL CODE
TO INCLUDE A DEFINITION OF A FAMILY ENTERTAINMENT CENTER

Section 1. Amendment: Section 150 "Definitions" of the Lake Elmo Municipal Code is hereby amended to include the definition of Family Entertainment Center, to wit:

Family Entertainment Center

Amusement facilities that may include indoor miniature golf, child play areas, arcade games, batting cages, birthday party and family celebration rooms, indoor soccer/field hockey, children's adventure play gardens and laser tag. Also typically included are a small food and beverage area and a small retail area. All facilities are non-alcoholic and smoke free.

Deleted: , indoor paint ball

Section 2. Effective Date: This ordinance shall become effective upon its passage and publication according to law.

ADOPTED by the Lake Elmo City Council this day of 2004.

Lee Hunt, Mayor

ATTEST:

Martin Rafferty, City Administrator

PUBLIC HEARING:

Amend Conditional Uses in the GB Zone – Family Entertainment Center

The Planner said the City Council was not any more interested in a 47,000 square foot use for a Family Entertainment Center in the Limited Business Zone than was the Planning Commission. The Council had suggested that the General Business District zoning might be more appropriate for this use. Therefore he is presenting it as a Conditional Use in the GB Zone with no maximum square footage limitation. He read the definition provided by a buyer of land in the city.

Commissioner Deziel noted that there is a big difference in LB vs. GB zoning.

The Planner said there are 5 locations along the I-94 corridor and the entire Old Village of the city which are zoned General Business. A Family Entertainment Center could be placed in any building in the GB Zone should the now proposed amendment be adopted.

Chairman Helwig reminded everyone that the Comprehensive Plan guides the property along I-94 mostly as Limited Business.

Commissioner Sedro said that property along the interstate is unique in many ways. She asked why this would be a bad idea.

The Planner said the typical suburban model zoning ordinance does not necessarily fit our city.

Commissioner Schneider asked if a business can be limited to be smoke-free and alcohol-free as a Conditional Use Permit condition.

The Planner said if the Commission approves the definition provided, then they don't have to deal with that limitation. It would already be a part of the definition of "Family Entertainment Center"

Commissioner Deziel suggested eliminating, "a new generation" from the Family Entertainment Center definition proposed.

THE CHAIRMAN OPENED THE PUBLIC HEARING AT 7:42 P.M.

Nobody offered testimony.

THE CHAIRMAN CLOSED THE PUBLIC HEARING AT 7:43 P.M.

Commissioner Sessing asked to remove the indoor paintball for safety reasons.

M/S/P, Ptacek/Sessing, To recommend amendment of the zoning ordinance to include Family Entertainment Center as a Condition Use in the General Business Zone, and striking "indoor paintball" from the proposed definition of "Family Entertainment Center.

Commissioner Johnson asked the Maker of the Motion if he would like to reconsider the indoor paintball to allow parents to make those choices for themselves and their families. Commissioner Schneider agreed.

Commissioner Ptacek said he believes Council might strike that portion of it, so he will let it stand.

Commissioner Sedro said the issues raised relative to size in Limited Business should be the same issues in GB if the city wants to keep out big box businesses.

The Planner said General Business is a more intense zoning district. If we are concerned about big boxes, a lot must be changed in the Zoning Ordinance.

Commissioner Ptacek said a Family Entertainment Center is too intense for Limited Business. He would be willing to consider it as a CUP in General Business.

The Planner said this use is now non-conforming in those zones, and the CUP lives only through the property on which it is placed.

Commissioner Sessing said this use is somewhat limited to scale by setbacks, etc.

Commissioner Deziel asked the Maker to set aside the Motion.

**M/S/F, Johnson/Schneider, To amend the Motion to remove the reference to indoor paintball.
VOTE: 3:4:1 (Deziel Abstain).**

VOTE on Original Motion: 5:3 Johnson, Helwig, and Schneider. All three Commissioners agree it is a parent's call not a city's call (to decide whether a child participates in paintball).

Commissioner Ptacek said the Commission is in favor of the use in the zone but disagrees on the definition.

M/S/P Johnston/Dunn – to amend the text in Section 302.02 Fence Materials, Subd. 3 – Chain Link or Cyclone Fences by striking “and shall be black or green in color”.
(Motion passed 3-1:DeLapp)

M/S/P Johnston/Dunn – to amend the text in Section 302.04 Temporary Fences, Subd. 1 – Defined to read “Temporary Fences shall be open to light and air over not less than “40%” of the fence surface area.” (Motion passed 4-0).

M/S/P Johnston/DeLapp – to amend the text in Section 302.06 Fences as Screening and Security as Required by This Code by adding “Item 4. No such screening shall be roofed or covered in any manner. (Motion passed 4-0).

The Council suggested that in Section 302.02 add Temporary Fences as exclusion to requiring a building permit. Council member Johnston asked if temporary fences are adequately defined. Attorney Filla responded that temporary fence definitions could have other fences; such as, garden, snow fences and swimming pool fences which are installed and removed on a seasonal basis.

M/S/P Johnston/DeLapp – to not require a building permit for temporary fences. (Motion passed 4-0).

Attorney Filla suggested adding the words “6 months administratively.”

M/S/P Johnston/John – to amend the text to read in Section 302.07, Item 1. Fence Permits Required: All such fences shall be removed by the property owner within 6 months of the termination of the keeping of Domestic Farm animals, unless an extension is specifically authorized by City Council action. (Motion passed 4-0).

M/S/P Johnston/John – to adopt Ordinance No. 97-137, Fence Ordinance, as amended. (Motion passed 4-0).

M/S/P Johnston/John to amend the agenda add 9B New Fence Ordinance and Repeal of Fence Moratorium. (Motion passed 4-0).

M/S/P Johnston/DeLapp – to repeal the Fence Moratorium. (Motion passed 4-0).

Planner Dillerud will address Council member Johnston’s concern on clarification of fences in the OHW setback in the shoreland ordinance.

C. Fence Moratorium Request at 55th Street North:

This agenda item was postponed to August 17th Council meeting per the request of resident, Tom McCormick.

D. Limited Business Zoning District – Add Family Entertainment Center:

This agenda item was tabled at the request of the applicant.

Lake Elmo City Council September 7, 2004	Agenda Section: Planning, Land Use & Zoning	<u>No.</u> 9B
<u>Agenda Item:</u> Amendments to Section 150 – Building Height		
<u>Background Information for September 7, 2004:</u> Responsive to Council direction on July 20, Staff has prepared a Draft Ordinance that would repeal the “old” Building Height definition, and amend the new Building Height Definition to allow highest point measurements from the highest ridge of a hip or gable roof.		
<u>Action items:</u> Motion to adopt Ordinance 97 - ¹⁴⁰ , amending Section 150 of the City Code regarding the definitions of Building Height.	<u>Person responsible:</u>  City Planner	
<u>Attachments:</u> ¹⁴⁰ 1. Draft Ordinance #97 - , Amending Section 150 2. City Council Minutes of July 20, 2004	<u>Time Allocated:</u>	

CITY OF LAKE ELMO
WASHINGTON COUNTY, MINNESOTA

ORDINANCE NO. 97-140

AN ORDINANCE AMENDING SECTION 150
OF THE LAKE ELMO MUNICIPAL CODE
TO REPEAL ONE DEFINITION OF BUILDING HEIGHT AND AMEND
THE REMAINING DEFINITION OF BUILDING HEIGHT

Section 1. Amendment: Section 150 "Definitions" of the Lake Elmo Municipal Code is hereby amended to amend the definition of Building Height, to wit:

Building Height

The vertical distance from the average of the highest and lowest point of grade for that portion of the lot covered by building to the highest point of the roof for flat roofs; to the roof deck line of mansard roofs; and to the mean height between eaves and the highest ridge for gable, hip and hambrel roofs.

Section 2. Repeal: Section 150 "Definitions" of the Lake Elmo City Code is hereby amended to repeal the definition of Building Height, to wit:

Building Height

The vertical distance between the lowest grade level at the building line and the uppermost point on the roof.

Section 3. Effective Date: This ordinance shall become effective upon its passage and publication according to law.

ADOPTED by the Lake Elmo City Council this day of 2004.

Lee Hunt, Mayor

ATTEST:

Martin Rafferty, City Administrator

M/S/P DeLapp/Johnston - to adopt Resolution No. 2004-059, A Resolution approving a variance to permit reconstruction of a pre-existing deck within the Shore land OHW of Downs Lake at 2225 Legion Lane per plans staff dated July 8, 2004, and based on the recommendation of the Planning Commission. (Motion passed 4-0).

B. Appeal of Administrative Determination: Anderson-Sorenson

The City Planner reported that the home builders in the Whistling Valley OP have appealed determination by the Building Official regarding the application of the definition of Building Height in Section 150 of the City Code. With an architectural feature such as proposed for the roof of this home, the issue is whether the mean height of the gable roof is to be measured from the first roof level or the second upper roof level.

He reported that the appellant contends that the measurement of gable roof mid point should be taken from the eaves and the top most ridge (the top of the second roof in this case). With that interpretation this home would meet the 35 foot max height. With the Building Official's more conservative interpretation, the calculated building height of this home would be 38 feet.

Phil Anderson, Anderson-Sorenson stated that the first home built in Whistling Valley is the same height as the one in question. Anderson said he felt the interpretation the builder proposes meets the intent of the Code. He said he was looking for a solid definition to guide their house design process.

Council member Johnston asked if this will start a precedent and come back to haunt the City. Attorney Miller responded the section of the code should be amended for better clarity.

Mayor Hunt suggested the Council approach the issue as we work on the performance zoning.

Administrator Rafferty noted it is important in the short term to adjust the code to reflect any City Council interpretations made as the result of an appeal.

M/S/P Johnston/John - to adopt a Board of Adjustment and Appeals Order directing the Building Official to interpret the definition of Building Height for a hip or gable roof to use the upper most ridge line of any structure as the upper point from which to measure the average height of a structure with a hip or gable roof and multiple ridge lines. (Motion passed 4-0).

M/S/P DeLapp/John - to direct the staff to adjust the code to preclude the first definition of Building Height and include this interpretation in the new (second) definition. (Motion passed 4-0).