

Lake Elmo - Developer Landscaping and Site Restoration Checklist:

The following checklist is provided as a summary of high-level expectations to ensure the installation of required landscaping in the City of Lake Elmo meets all City requirements including those in the zoning code, development agreement, and approved development plan. *This list is intended to act as a guide to ensure a shared understanding of City expectations for the required landscaping installation work and standards. It is not a comprehensive list of requirements.*

The developer bears final responsibility for all requirements and shall be responsible for coordination between their contractors and the City.

Before the Pre-Installation Conference, the Contractor and Developer shall:

- SCHEDULING – The developer shall contact the City to schedule the required pre-installation conference prior to installing any work.
 - **Work installed without completing this step will be rejected, no exceptions.**
- IRRIGATION - Have read and understood the approved watering plan and schedule prior to the meeting.
 - The contractor may want to coordinate with the Home-owners Association to control irrigation during the warranty period.
- PHASING – To qualify for phased inspections a development be residential and must contain at least 200 trees. There can be at most two phases:
 - Developer phase: includes all trees lot in front of buildable lots which may be impacted by home construction.
 - Builder phase: Remaining required landscaping and restoration.
 - The intent of phased landscaping is to avoid artificially extending the landscape warranty period for improvements installed prior to development build out. Each phase will receive its own acceptance date starting the two-year warranty for that phase within the overall project.
 - **All phases within an overall project or addition must be completed before the initial or final surety releases can be granted.**
 - There will be no partial surety release resulting from the acceptance of a landscaping phase unless previously agreed to by the City.
- STAKING - Stake all tree locations for City approval prior to installation. The Contractor and Developer shall:
 - Coordinate staking to ensure tree locations match the approved development plan.

- Ensure adjusted tree locations of more than 10 feet from the approved plan location must be tracked in an 'as-built' plan. That plan shall be provided to the City prior to requesting an initial inspection. An inspection will not be conducted without an accurate 'as-built' plan.
- Stake limits of easements to ensure no tree locations occurs within:
 - 10ft of front and rear lot lines
 - 5ft of side yard or shared property lines
 - Trees within an easement, regardless of staked location, will require relocation at the time they are identified.
- TREE STOCK - Notify the City's Landscape Architect at least 10 calendar days prior to the installation of trees to schedule an inspection of the tree material prior to installation. This inspection can occur onsite immediately before planting.
 - Twine, burlap, and cages can be left in place if the contractor can demonstrate that plant stock has been planted with the root flare at the top of the root ball's soil mass AND that the twine is organic biodegradable material.
 - At the discretion of the City's Landscape Architect, trees with trunk wounds, deformities, disease, or significant damage will not be accepted.

During the Pre-Installation Conference, the Contractor and Developer shall:

- EXAMPLE INSTALLATION - Install three deciduous and three coniferous trees under the observation of the City's Landscape Architect to confirm understanding of the City's Landscape Special Provisions, MnDOT Standard Specifications Section 2571 and MnDOT Standard Plan 5-297.301 Standard Planting Details A-C planting requirements. Failure to compile will result in rejection of the tree.
 - If trees are to be installed on grades greater than 1:5, one observed example installations shall be of that type for both deciduous and coniferous.
 - Of particular importance is locating, exposing, and placing the root flare at an elevation just above grade. Failure to do so will result in the rejection of the tree, regardless of condition.

During or Immediately Following Installation, the Contractor and Developer shall:

- INSTALLATION TIMING – Must align with the MnDOT table below unless otherwise agreed to by the City and the City's Landscape Architect.
 - The installation timing of landscape material is critical to establishment success. The installation of all plant material for a project shall comply with the Planting Dates table MnDOT Standard Plan 5-297.301 Standard Planting Details A table.

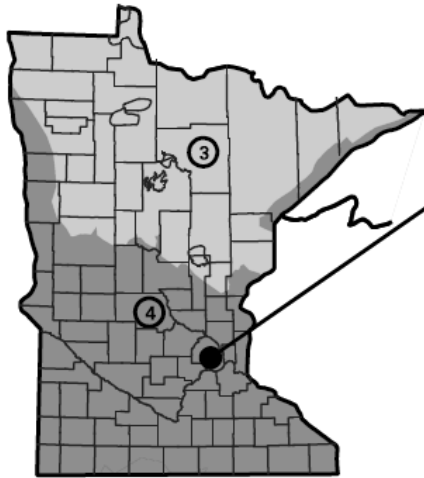

PROJECT LOCATION

PLANTING DATES BY ZONE

			③	④
SPRING	DECIDUOUS	BARE ROOT	APRIL 21 TO JUNE 1	APRIL 7 TO JUNE 1
		CONTAINER B&B	APRIL 21 TO JUNE 30	APRIL 7 TO JUNE 30
	CONIFEROUS		APRIL 21 TO JUNE 1	APRIL 7 TO MAY 17
	PERENNIALS		MAY 1 TO JUNE 30	MAY 1 TO JUNE 30
	SEEDLINGS		APRIL 21 TO JUNE 1	APRIL 7 TO JUNE 1
FALL	DECIDUOUS	BARE ROOT	OCT. 1 TO NOV. 1	OCT. 10 TO NOV. 15
		CONTAINER B&B	AUG. 25 TO OCT. 15	AUG. 25 TO NOV. 1
	CONIFEROUS		AUG. 25 TO SEPT. 15	AUG. 25 TO SEPT. 15
	PERENNIALS		AUG. 25 TO SEPT. 15	AUG. 25 TO SEPT. 15

1. BARE ROOT PERENNIALS MUST BE INSTALLED IN THE SPRING NO LATER THAN JUNE 1ST OR FOLLOW THE FALL DECIDUOUS PLANTING DATES.
2. ACTUAL DATES MAY CHANGE DEPENDING UPON SEASONAL CONDITIONS, AS DETERMINED BY THE ENGINEER.
3. FALL PLANTING IS NOT ALLOWED FOR BARE ROOT FORM OF THE FOLLOWING SPECIES: HAWTHORN, DOGWOOD, POPLAR, HACKBERRY, LINDEN, IRONWOOD, HONEYLOCUST, BIRCH, MOUNTAIN ASH, MAPLE, WILLOW, CRABAPPLE, PLUMCHERRY, OAKS, AND SUMAC.
4. ALL REPLACEMENT PLANTS MUST BE INSTALLED DURING THE MONTH OF MAY (SPRING PLANTING) AND SEPTEMBER (FALL PLANTING) DURING THE FIRST YEAR OF THE PLANT ESTABLISHMENT PERIOD.
5. MACHINED MOVED PLANTING DATES WILL BE SPECIFIED IN THE SPECIAL PROVISIONS.

-
- PLANTING - Ensure tree pits comply with size requirements listed in [the MnDOT Standard Plan 5-297.301 Standard Planting Details A-C](#)
 - [Failure to compile with specified hole sizing will result in rejection of the tree.](#)
- WATERING - Water-in trees and landscaping at the time of installation to ensure adequate soil moisture and proper soil settlement around the root ball. A minimum of 15 gallons of water per tree shall be applied during the initial watering.
 - [Failure to compile will result in rejection of the tree.](#)
- AS-BUILT PLAN - Provide the City’s Landscape Architect with an irrigation as-built plan or, if manual watering is to be performed in lieu of irrigation, a watering plan and schedule to ensure adequate water is supplied to support the establishment of trees and landscaping.
- MAINTENANCE - Be responsible for the maintenance of mulch rings, planting beds, and ground cover areas throughout the entire warranty period. This includes:
 - Replenishing mulch at trees and beds to maintain required depth and size.

- Ensuring weed control throughout the growing season.
- Preventing soil and seed contamination when restoring seeded areas or after replanting or landscaping.
- RESTORATION - Restore ground-cover areas disturbed during the warranty period within 15 calendar days of notification.
 - Disturbance areas may require regrading to return the area to the designed final grade.
 - Areas where substantial or repeated erosion occurs will require additional correction that includes erosion control blanketing, until seed has completely established.

Inspections, Warranty Timing, and Corrections:

- INSPECTION PHASES -
 - Initial acceptance: Once all material for a project is installed and deemed ready by the developer for inspection the City's Landscape Architect will inspect for compliance. Compliance for all required landscape materials must be met to begin the warranty period. Financial surety phase one release will not occur until this initial acceptance is obtained.
 - Final acceptance: Starting no earlier than two years from the date of initial acceptance, the project is eligible for inspection by the City's Landscape Architect to determine compliance for final acceptance. Compliance for all required landscape materials must be met to close-out the warranty period. Financial surety phase two release will not occur until this final acceptance is obtained.
- INSPECTION SCHEDULING - The developer is responsible for contacting the City to request an inspection of completed work.
 - All landscaping work must be entirely complete, partial work inspections will not be performed.
- RESPONSE TO INSPECTION MEMO FINDINGS AND REQUIREMENTS - Following the receipt of inspection findings (memo from the City) the contractor shall have 60 calendar days to perform the corrections and replacements identified in the recommendations section, unless timing of replacements does not meet the requirements in the Planting Dates by Zone table above. In these cases the contractor should perform the corrections at the earliest possible opportunity within the next planting window. If there are concerns about weather, plant material sourcing, etc. these concerns must be communicated to the City within 21 calendar days.

- Plant substitution requests must be reviewed and approved by the City's Landscape Architect prior to use.

GENERAL NOTES

SEE SPECIAL PROVISIONS FOR SPECIFIC PROJECT REQUIREMENTS.

REFER TO MnDOT SPECIFICATIONS 2571, 3861, AND THE "2015" INSPECTION AND CONTRACT ADMINISTRATION MANUAL FOR MnDOT LANDSCAPE PROJECTS" FOR GENERAL REQUIREMENTS.

COMPLETE PREPARATORY WORK BEFORE STARTING INITIAL PLANTING OPERATIONS.

ACCEPT ALL PLANT STOCK IN ACCORDANCE WITH (MnDOT 3861) PRIOR TO PLANTING.

THE CONTRACTOR WILL DEMONSTRATE COMPETENCY FOR SOIL CULTIVATION OPERATIONS IN ACCORDANCE WITH (MnDOT 2571.3D2 STEP 4)

THE CONTRACTOR WILL DEMONSTRATE COMPETENCY FOR ALL PLANT INSTALLATION OPERATIONS IN ACCORDANCE WITH (MnDOT 2571.3F1)

RODENT PROTECTION SEE SPECIAL PROVISIONS AND STANDARD PLANTING DETAILS (C)

FERTILIZER SEE SPECIAL PROVISIONS

COMPOST MnDOT 3890 GRADE 2 UNLESS OTHERWISE SPECIFIED.

MULCH MATERIAL MnDOT 3882 TYPE 6 UNLESS OTHERWISE SPECIFIED.

MASS PLANTING BEDS PREPARE MASS PLANTING BEDS FOR PLANTS PLACED AT 15' OR LESS, UNLESS OTHERWISE SPECIFIED ON SHEETS. PLANT BEDS IN STAGGERED ROWS ON THE PERIMETER FIRST, THEN UNIFORMLY FILL IN WITH REMAINING PLANTS. USE TRIANGULAR SPACING, UNLESS SPECIFIED OTHERWISE. PROVIDE 5' RADIUS CLEAR OF SHRUBS AROUND EACH DECIDUOUS TREE AND 8' CLEAR RADIUS AROUND EACH CONIFER TREE. RADIUS WILL BE MEASURED FROM THE CENTER OF THE TREE TO THE CENTER OF THE SHRUB. NOTIFY ENGINEER OF GROSS PLANT QUANTITY SURPLUS OR DEFICIENCY IMMEDIATELY. MULCH ENTIRE MASS PLANTING BED. SEE STANDARD PLANTING DETAILS (C)

TREE PAINTING (FROST CRACK PREVENTION) PAINT OAK, LINDEN, LOCUST, MAPLE, CRABAPPLE AND MOUNTAIN ASH. ONLY UNDILUTED EXTERIOR WHITE LATEX PAINT IS ACCEPTABLE. PAINT TREE CIRCUMFERENCE FROM GROUND LINE TO FIRST MAJOR BRANCH.

PLANTING PLAN DIMENSIONS STATED DIMENSIONS SUPERCEDE SCALING FROM PLAN.

WATERING GUIDELINES (MnDOT 2571.3G)	PLANT TYPE	AVERAGE GALLONS OF WATER PER APPLICATION
	MACHINE TRANSPLANTED TREES	50-100
	BALLED AND BURLAPPED TREES	20
	BARE ROOT AND CONTAINER TREES	15
	BALLED AND BURLAPPED SHRUBS	10
	BARE ROOT AND CONTAINER SHRUBS	7
	WOODY SEEDLINGS	4
	PERENNIALS AND VINES	3

IT IS THE CONTRACTOR'S RESPONSIBILITY TO MONITOR AND MAINTAIN SOIL MOISTURE AT ADEQUATE BUT NOT EXCESSIVE LEVELS. THE AMOUNTS LISTED ABOVE ARE GUIDELINES, NOT REQUIREMENTS.

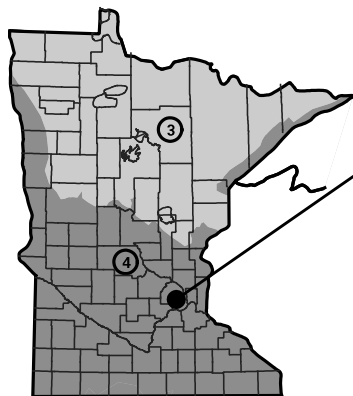

PROJECT LOCATION

PLANTING DATES BY ZONE

		③	④	
SPRING	DECIDUOUS	BARE ROOT	APRIL 21 TO JUNE 1	APRIL 7 TO JUNE 1
		CONTAINER B&B	APRIL 21 TO JUNE 30	APRIL 7 TO JUNE 30
	CONIFEROUS	APRIL 21 TO JUNE 1	APRIL 7 TO MAY 17	
	PERENNIALS	MAY 1 TO JUNE 30	MAY 1 TO JUNE 30	
	SEEDLINGS	APRIL 21 TO JUNE 1	APRIL 7 TO JUNE 1	
FALL	DECIDUOUS	BARE ROOT	OCT. 1 TO NOV. 1	OCT. 10 TO NOV. 15
		CONTAINER B&B	AUG. 25 TO OCT. 15	AUG. 25 TO NOV. 1
	CONIFEROUS	AUG. 25 TO SEPT. 15	AUG. 25 TO SEPT. 15	
	PERENNIALS	AUG. 25 TO SEPT. 15	AUG. 25 TO SEPT. 15	

- BARE ROOT PERENNIALS MUST BE INSTALLED IN THE SPRING NO LATER THAN JUNE 1ST OR FOLLOW THE FALL DECIDUOUS PLANTING DATES.
- ACTUAL DATES MAY CHANGE DEPENDING UPON SEASONAL CONDITIONS, AS DETERMINED BY THE ENGINEER.
- FALL PLANTING IS NOT ALLOWED FOR BARE ROOT FORM OF THE FOLLOWING SPECIES: HAWTHORN, DOGWOOD, POPLAR, HACKBERRY, LINDEN, IRONWOOD, HONEYLOCUST, BIRCH, MOUNTAIN ASH, MAPLE, WILLOW, CRABAPPLE, PLUMCHERRY, OAKS, AND SUMAC.
- ALL REPLACEMENT PLANTS MUST BE INSTALLED DURING THE MONTH OF MAY (SPRING PLANTING) AND SEPTEMBER (FALL PLANTING) DURING THE FIRST YEAR OF THE PLANT ESTABLISHMENT PERIOD.
- MACHINED MOVED PLANTING DATES WILL BE SPECIFIED IN THE SPECIAL PROVISIONS.

PLANT INSTALLATION PERIOD

(MnDOT 2571.3F2)

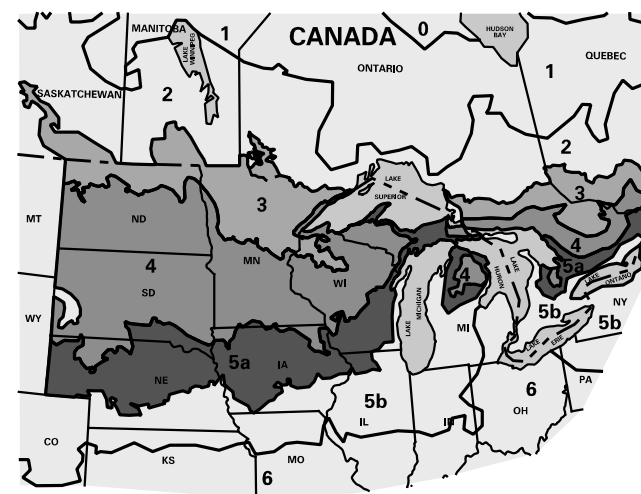

ACCEPTABLE ZONES		
ZONES	LEGEND	MIN. TEMP.
3		-34.4° TO -40° F
4		-28.9° TO -34.4° F
5a		-26.1° TO -28.9° F

UNACCEPTABLE ZONES	
ZONES	LEGEND
0, 1, 2, 5b and 6	

FOR ALL PLANT STOCK, DOCUMENT ACCEPTABILITY FOR HARDINESS IN THE MINNESOTA ZONE WHERE THE PROJECT SITE IS LOCATED, AS FOLLOWS:

- A. PLANT STOCK CONTINUOUSLY GROWN FOR AT LEAST THE LAST TWO YEARS WITHIN THE ACCEPTABLE LIMITS SHOWN.
- OR
- B. PLANT STOCK, GROWN OUTSIDE THE ACCEPTABLE GROWING RANGE LIMITS, HAVING SEED SOURCE OR ROOT AND GRAFT STOCK ORIGINATING FROM THE ACCEPTABLE LIMITS SHOWN.

ACCEPTABLE PLANT STOCK GROWING RANGE LIMITS

SOURCE: USDA PLANT HARDINESS ZONE MAP

(MnDOT 3861.2C)

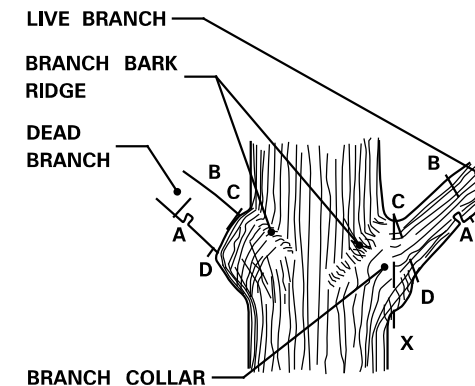

- STEPS TO PRUNING WITH PRUNING SAW:**
- CUT PART WAY THROUGH THE BRANCH AT POINT A.
 - CUT COMPLETELY THROUGH BRANCH FROM POINT B TO A.
 - AT BRANCH COLLAR CUT FROM POINT C TO D.

INCORRECT CUT FROM POINT C TO X (TOO CLOSE) WILL RESULT IN DISCONTINUOUS CALLUS FORMATION AFTER ONE SEASON OF GROWTH.

CORRECT CUT FROM POINT C TO D (LEAVING BRANCH COLLAR BUT NOT THE STUB FROM POINT B TO A) WILL RESULT IN CONTINUOUS DOUGHNUT SHAPED CALLUS FORMATION AFTER ONE SEASON OF GROWTH.

BRANCHES PRUNED AT TRUNK

(SHIGO METHOD)

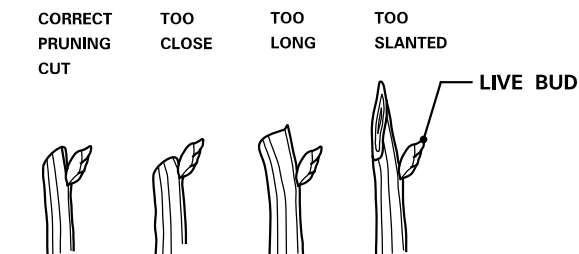

PRUNING NOTES:

- PRUNE USING CLEAN AND SHARP SCISSOR-TYPE PRUNER OR PRUNING SAW.
- THE BEST TIME TO PRUNE IS LATE DORMANT SEASON OR EARLY SPRING.
- AVOID PRUNING OAKS IN APRIL, MAY, JUNE OR JULY.
- IF PRUNING IS NECESSARY OR IF WOUNDS OCCUR TO OAK TREES IN APRIL, MAY, JUNE OR JULY, IMMEDIATELY PAINT CUT SURFACE OR WOUND WITH LATEX PAINT OR SHELLAC.

BRANCHES PRUNED TO LIVE BUD

PRUNING

(MnDOT 2571.3K2a9 and 2571.3E1)

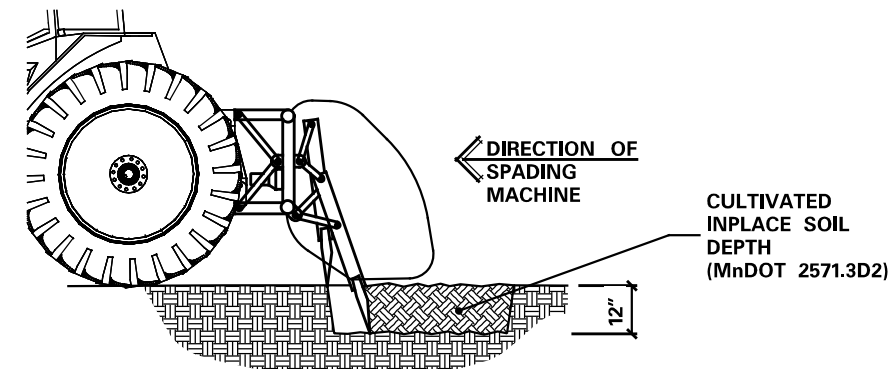

PRIMARY TILLAGE - PASS 1

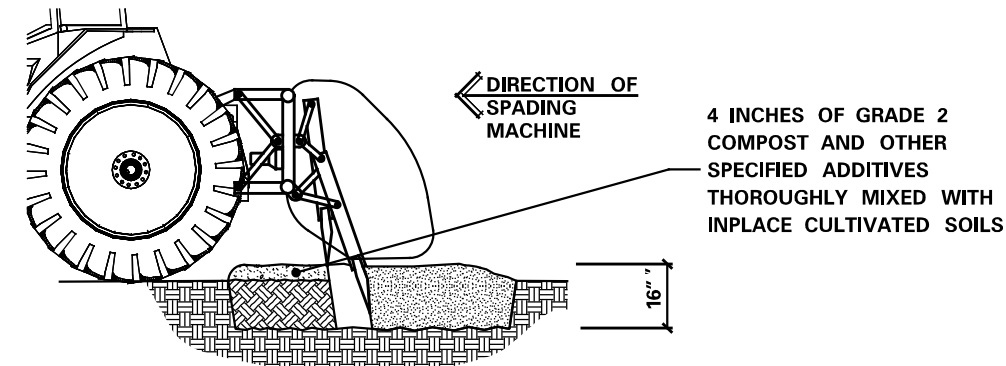

INCORPORATION TILLAGE - PASS 2

PLANTING SOIL

(MnDOT 2571.3D2)

DATE PRINTED:
REVISED - JANUARY / 01 / 2014

PROJECT MANAGER
DAVID LARSON

DRAWN BY
OFFICE OF ENVIRONMENTAL STEWARDSHIP



STATE OF MINNESOTA
DEPARTMENT OF TRANSPORTATION
OFFICE OF ENVIRONMENTAL STEWARDSHIP
ENV. PLANNING AND DESIGN UNIT
TRANSPORTATION BUILDING
ST. PAUL, MINNESOTA 55155-1899

STANDARD PLANTING DETAILS (A)

STATE PROJECT SP 1901-171 (T.H. 13)

SHEET NO. 7 OF 9 SHEETS

PLANTING HOLE DIMENSIONS			
HOLE DEPTH FOR B&B AND CONTAINER PLANTS SHALL NOT EXCEED MEASUREMENT FROM ROOT FLAIR TO BOTTOM OF SOIL BALL.			
PLANT TYPE	PLANT SIZE UP TO AND INCLUDING	(A) MINIMUM HOLE WIDTH	(B) APPROXIMATE HOLE DEPTH
DECIDUOUS & ORNAMENTAL TREES	3" B.R.	46"	13"
	4" B.R.	46"	14"
	5" B.R.	48"	14"
	6" B.R.	54"	15"
	7" B.R.	60"	16"
	8" B.R.	66"	19"
	0.75" B.R.	48"	12"
	1" B.R.	54"	14"
	1.25" B.R.	60"	14"
	1.5" B.R.	66"	15"
	1.75" B.R.	72"	16"
	2" B.R.	84"	19"
	4" B.B.	42"	11"
	5" B.B.	48"	12"
	6" B.B.	52"	14"
	8" B.B.	66"	16"
	10" B.B.	66"	16"
	12" B.B.	48"	16"
	1" B.B.	54"	14"
	1.25" B.B.	56"	15"
1.5" B.B.	61"	15"	
1.75" B.B.	66"	16"	
2" B.B.	72"	16"	
2.5" B.B.	84"	19"	
3" B.B.	96"	20"	
3.5" B.B.	114"	23"	
4" B.B.	126"	25"	
DECIDUOUS SHRUBS, ROSES AND PERENNIALS	12" B.R.	24"	7"
	15" B.R.	28"	8"
	18" B.R.	30"	8"
	2" B.R.	33"	9"
	3" B.R.	42"	11"
PERENNIAL HOLE DEPTH AND WIDTH SHALL BE BASED UPON ON-CENTER SPACING IN A CONTINUOUS TRENCH.	4" B.B.	48"	12"
	5" B.R.	54"	14"
	6" B.R.	60"	14"
	18" B.B.	27"	7"
	2" B.B.	30"	8"
	3" B.B.	36"	9"
4" B.B.	42"	11"	
5" B.B.	48"	12"	
6" B.B.	54"	14"	

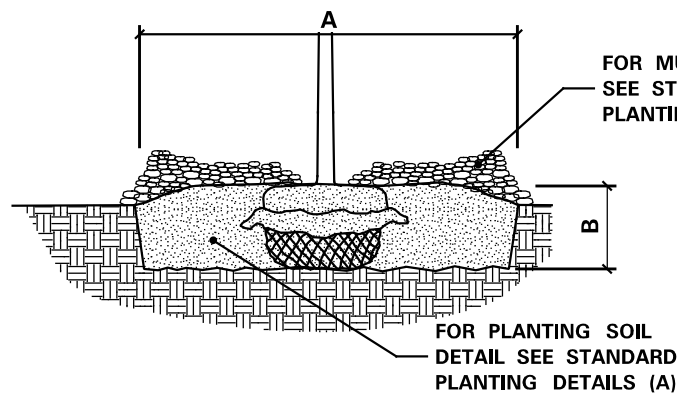

1. SCARIFY SIDES AND BOTTOM OF HOLE.
2. PROCEED WITH CORRECTIVE PRUNING.
3. SET PLANT ON UNDISTURBED NATIVE SOIL OR THOROUGHLY COMPACTED PLANTING SOIL. INSTALL PLANT SO THE ROOT FLARE IS AT OR UP TO 2" ABOVE THE FINISHED GRADE WITH BURLAP AND WIRE BASKET, (IF USED), INTACT.
4. SLIT REMAINING TREATED BURLAP AT 6" INTERVALS.
5. BACKFILL TO WITHIN APPROXIMATELY 12" OF THE TOP OF THE ROOTBALL, THEN WATER PLANT.
6. REMOVE THE TOP 1/3 OF THE BASKET OR THE TOP TWO HORIZONTAL RINGS WHICHEVER IS GREATER. REMOVE ALL BURLAP AND NAILS FROM THE TOP 1/3 OF THE BALL. REMOVE ALL TWINE, REMOVE OR CORRECT STEM GIRDLING ROOTS.
7. PLUMB AND BACKFILL WITH PLANTING SOIL.
8. WATER THOROUGHLY WITHIN 2 HOURS TO SETTLE PLANTS AND FILL VOIDS.
9. BACK FILL VOIDS AND WATER A SECOND TIME.
10. PLACE MULCH WITHIN 48 HOURS OF THE SECOND WATERING UNLESS SOIL MOISTURE IS EXCESSIVE.

BALLED & BURLAPPED STOCK

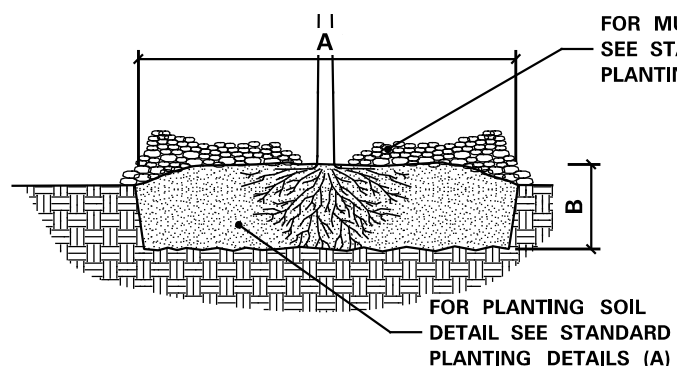

1. SOAK ROOTS IN WATER FOR AT LEAST ONE HOUR BUT NOT MORE THAN 24 HOURS PRIOR TO PLANTING.
2. SCARIFY SIDES AND BOTTOM OF HOLE.
3. PROCEED WITH CORRECTIVE PRUNING OF THE TOP AND ROOTS.
4. TRANSFER PLANT DIRECTLY FROM WATER TO HOLE. SET PLANT SO THE ROOT FLARE IS AT THE FINISHED SOIL ELEVATION. SPREAD ROOTS OUT EVENLY. PLUMB AND IMMEDIATELY BACKFILL WITH PLANTING SOIL.
5. WATER THOROUGHLY WITHIN 2 HOURS TO SETTLE PLANTS AND FILL VOIDS.
6. BACK FILL VOIDS AND WATER A SECOND TIME.
7. PLACE MULCH WITHIN 48 HOURS OF THE SECOND WATERING UNLESS SOIL MOISTURE IS EXCESSIVE.

BARE ROOT STOCK

INSTALLATION OF PLANTS

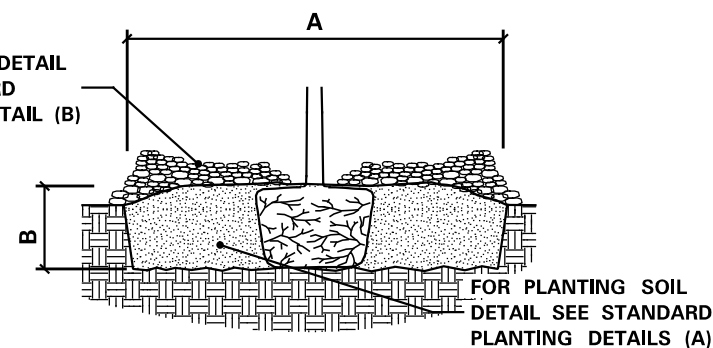

1. SCARIFY SIDES AND BOTTOM OF HOLE.
2. PROCEED WITH CORRECTIVE PRUNING OF TOP AND ROOT.
3. REMOVE CONTAINER AND SCORE OUTSIDE OF SOIL MASS TO REDIRECT AND PREVENT CIRCLING FIBROUS ROOTS. REMOVE OR CORRECT STEM GIRDLING ROOTS.
4. SET PLANT ON UNDISTURBED NATIVE SOIL OR THOROUGHLY COMPACTED PLANTING SOIL. INSTALL PLANT SO THE TOP OF THE ROOT FLARE IS AT OR UP TO 2" ABOVE THE FINISHED GRADE.
5. PLUMB AND BACKFILL WITH PLANTING SOIL.
6. WATER THOROUGHLY WITHIN 2 HOURS TO SETTLE PLANT AND FILL VOIDS.
7. BACK FILL VOIDS AND WATER A SECOND TIME.
8. PLACE MULCH WITHIN 48 HOURS OF THE SECOND WATERING UNLESS SOIL MOISTURE IS EXCESSIVE.

CONTAINER STOCK

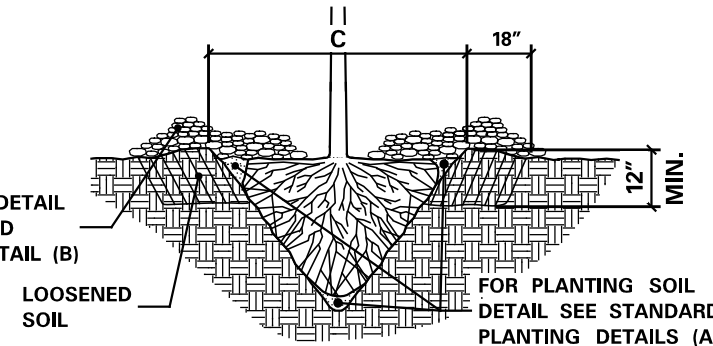

1. SCARIFY SIDES AND BOTTOM OF HOLE.
2. PROCEED WITH CORRECTIVE PRUNING.
3. SET PLANT ON NATIVE SOIL AT SAME DEPTH AS IT WAS PREVIOUSLY GROWN.
4. PLUMB AND BACKFILL WITH PLANTING SOIL.
5. AFTER PLANTING, LOOSEN THE SOIL IMMEDIATELY ADJACENT TO THE ROOT BALL TO A MINIMUM DISTANCE OF 18" AND A MINIMUM DEPTH OF 12".
6. WATER THOROUGHLY WITHIN 2 HOURS TO SETTLE PLANT AND FILL VOIDS.
7. BACK FILL VOIDS AND WATER A SECOND TIME.
8. PLACE MULCH WITHIN 48 HOURS OF THE SECOND WATERING UNLESS SOIL MOISTURE IS EXCESSIVE.

MINIMUM TREE SPADE SIZE REQUIREMENTS

(C) SPADE DIAMETER SIZE	OAK TREE, CALIPER	DECIDUOUS/ ORNAMENTAL TREE, CALIPER	CONIFEROUS TREE, HEIGHT
42"	1" to 1.5"	2" to 3"	5' to 7'
60"	1.5" to 2.5"	3" to 4"	7' to 9'
78"	2.5" to 3.5"	4" to 6"	9' to 14'
85"	3.5" to 5"	6" to 8"	14' to 18'

MACHINE MOVED STOCK

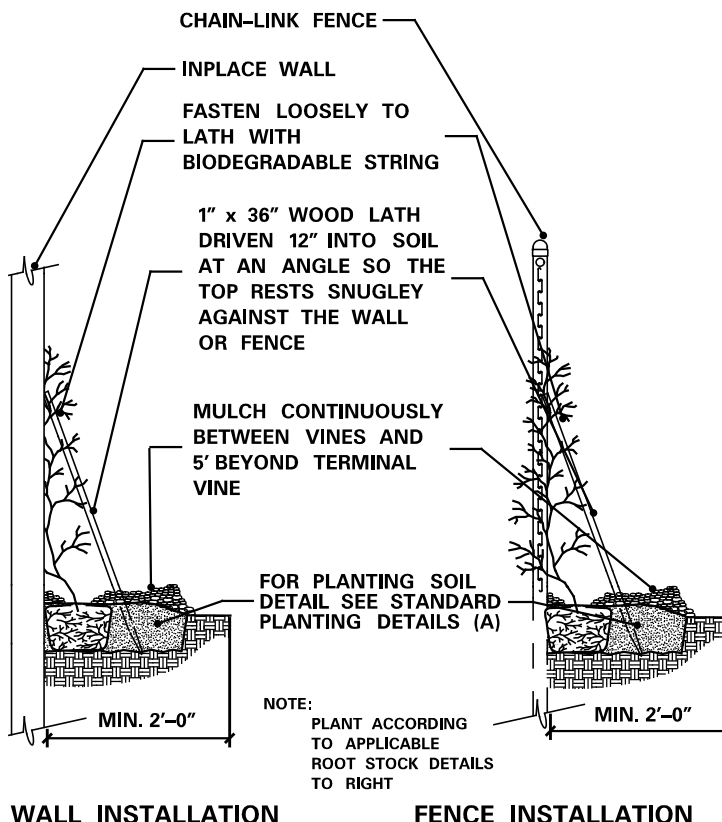

INSTALLATION OF VINES

PLANTING HOLE DIMENSIONS			
HOLE DEPTH FOR B&B AND CONTAINER PLANTS SHALL NOT EXCEED MEASUREMENT FROM ROOT FLAIR TO BOTTOM OF SOIL BALL.			
PLANT TYPE	PLANT SIZE UP TO AND INCLUDING	(A) MINIMUM HOLE WIDTH	(B) APPROXIMATE HOLE DEPTH
CONIFEROUS TREES	2" B.B.	36"	10"
	3" B.B.	42"	11"
	4" B.B.	51"	13"
	5" B.B.	60"	13"
	6" B.B.	66"	15"
	7" B.B.	72"	16"
	8" B.B.	81"	18"
	9" B.B.	90"	20"
	10" B.B.	102"	21"
	12" B.B.	114"	24"
CONIFEROUS SHRUBS (UPRIGHT)	18" SPR B.B.	30"	8"
	2" SPR B.B.	36"	9"
CONIFEROUS SHRUBS (SPREADING)	CELLPACKS / PLUGS	6"	2.5"
	2.25" CONT.	7"	3"
	3.5" CONT.	10"	3"
	4" CONT.	11"	4"
	4.5" CONT.	13"	4"
	6" QT CONT.	15"	5.5"
	1# CONT.	18"	6"
	2# CONT.	23"	7.5"
	3# CONT.	29"	8.5"
	5# CONT.	30"	11"
	7# CONT.	37"	11"
	15# CONT.	44"	14"
SEEDLINGS	10# CONT.	45"	15"
	20# CONT.	60"	16"
	25# CONT.	72"	17"
	6" SEEDLING	15"	14"
	9" SEEDLING	18"	14"
	12" SEEDLING	23"	16"
VINES	18" SEEDLING	30"	16"
	2" SEEDLING	36"	18"
	1 YR. MED. B.R.	15"	11"
	1 YR. NO. 1 B.R.	17"	14"
2 YR. MED. B.R.	33"	12"	
2 YR. NO. 1 B.R.	42"	15"	

MULCH AREA CALCULATOR

TYPE OF PLANT	SQ. FT. PER PLANT
CONIFEROUS TREES	$\left[\left(\frac{3}{5} \times \text{HEIGHT} \right) + 3 \right]^2 \times \pi$
DECIDUOUS AND ORNAMENTAL TREES	$3^2 \times \pi$
CONIFEROUS AND DECIDUOUS SHRUBS, ROSE BUSHES, PERENNIALS, ORNAMENTAL GRASS	SPACING x SPACING
VINES	SPACING x 2
MACHINE-MOVED TREES OR SHRUBS	$\left[\left(\frac{\text{SPADE DIAMETER}}{2} \right) + 1 \right]^2 \times \pi$

$\pi = 3.1416$

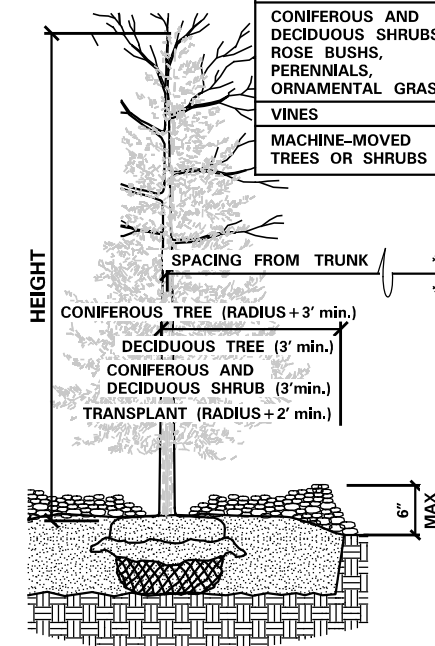

1. PULL MULCH BACK NO LESS THAN 3" AND NO MORE THAN 6" FROM TRUNK AND SHRUBS AT THE TRUNK OR MAIN STEM.
2. SUBSIDING OR DETERIORATING MULCH IS ACCEPTABLE THROUGHOUT THE ESTABLISHED PERIOD IF THE MULCH DEPTH IS MAINTAINED AT A MINIMUM 3" DEPTH.
3. ADD MULCH WHEN BELOW THE 3" MINIMUM DEPTH, DO NOT EXCEED THE 6" MAXIMUM DEPTH.
4. MULCH CONTAMINATED WITH SOIL MUST BE REMOVED AND REPLACED.

MULCH PLACEMENT



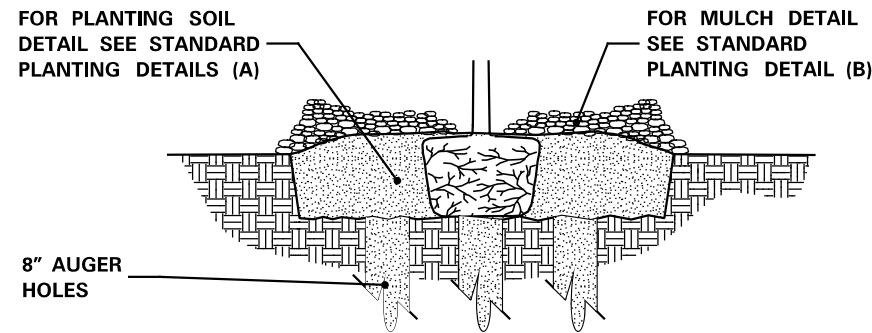

1. EXCAVATE HOLE OR BED TO ALLOW PLACING THE TOP OF ROOT MASS 1"-3" HIGHER THAN FINISHED GRADE.
2. AUGER 8" DIAMETER HOLES ENTIRELY THROUGH IMPERVIOUS OR POORLY DRAINED HARD PAN SOIL LAYER TO ADEQUATELY DRAIN SUBSOIL.
3. TEST FOR POSITIVE DRAINAGE. RE-AUGER AN ADDITIONAL 8" IF NECESSARY FOR POSITIVE DRAINAGE.
4. THOROUGHLY BACKFILL AUGER HOLES WITH A UNIFORM INCORPORATED MIXTURE OF 50% SAND AND 50% INPLACE SOIL.
5. COMPLETE PLANTING ACCORDING TO ROOT TYPE. SEE STANDARD PLANTING DETAILS (B).

INSTALL GRANULAR FILTER

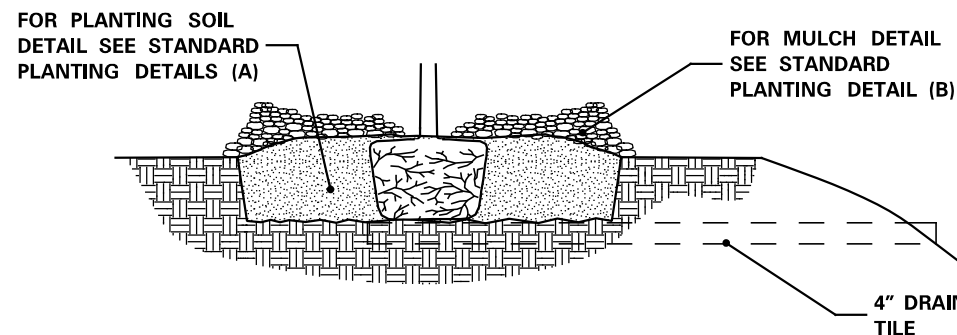

1. EXCAVATE HOLE OR BED TO ALLOW PLACING THE TOP OF THE ROOT MASS 1"-3" HIGHER THAN FINISHED GRADE.
2. INSTALL 4" MINIMUM DIAMETER DRAIN TILE DAYLIGHTING AT A LOWER GRADE.
3. COMPLETE PLANTING ACCORDING TO ROOT TYPE. SEE STANDARD PLANTING DETAILS (B).

INSTALL TILE DRAINAGE

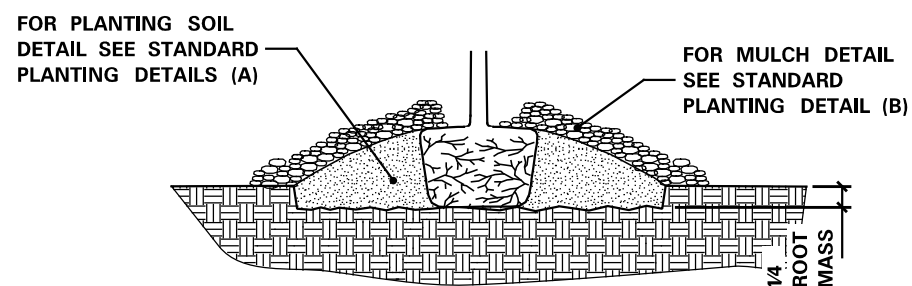

1. EXCAVATE HOLE OR BED 1/4 THE DEPTH OF THE ROOT MASS.
2. SET ROOT MASS IN HOLE.
3. CONSTRUCT BERM WITH PLANTING SOIL. EXTEND THE BERM BASE TO A WIDTH OF 3 TIMES THE BERM HEIGHT.
4. COMPLETE PLANTING ACCORDING TO ROOT TYPE. SEE STANDARD PLANTING DETAILS (B).

INSTALL MINI-BERM

- NOTE:
1. THE NEED FOR USING PLANTING DETAILS FOR POORLY DRAINED SOILS AND WHICH TYPE TO USE ARE DETERMINED BY THE CONTRACTOR, SUBJECT TO ENGINEER APPROVAL.

PLANTING DETAIL FOR POORLY DRAINED SOILS

(MnDOT 2571.3D2 (STEP 8))

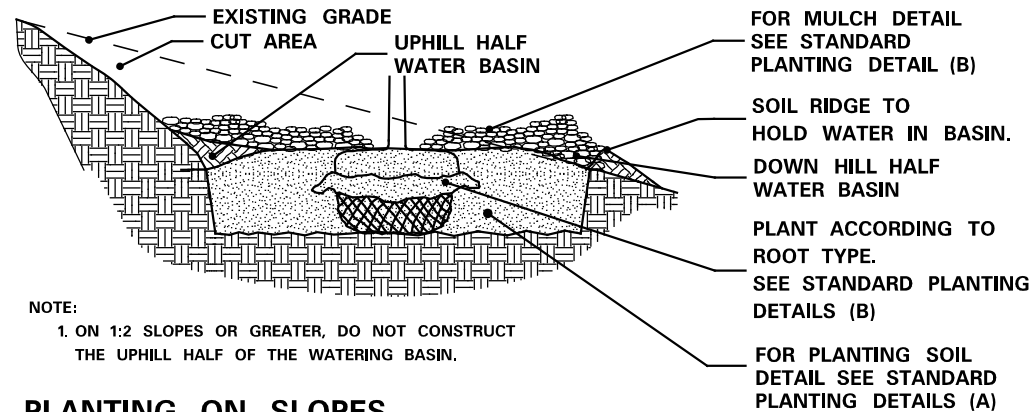

PLANTING ON SLOPES

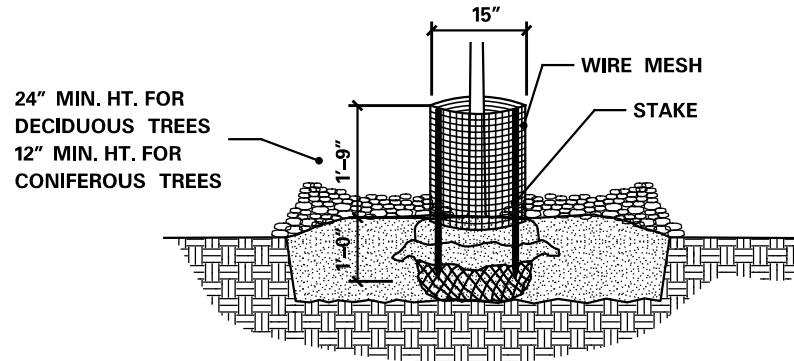

1. FORM A DOUBLE-LAYERED CYLINDER USING 0.25" GRID GALVANIZED WELDED WIRE MESH (HARDWARE CLOTH). OVERLAP THE CUT END 2".
2. DRIVE TWO 1" x 1" OPPOSING HEARTWOOD WHITE OAK STAKES INTO THE GROUND, 7" FROM THE CENTER OF THE TREE STEM.
3. SECURE THE MESH CYLINDER TO THE OUTSIDE OF THE STAKES USING EITHER, SCREWS AND WASHERS OR CABLE-TIES ALONG THE OVERLAP. SPACE APPROXIMATELY 4" ON CENTER ALONG THE OVERLAP.
 - a. SCREWS SHALL BE ROUND HEAD GALVANIZED 18" DIA. x 3/4" LONG WITH WASHERS.
 - OR
 - b. CABLE-TIES SHALL BE NYLON, AT LEAST 8" LONG AND BETWEEN 75LB TO 120LB TENSILE STRENGTH.
4. EMBED THE LOWER EDGE OF THE MESH CYLINDER 1" BELOW THE SOIL SURFACE WITHOUT DISTURBING THE TREE ROOTS.
5. CUT EDGES WILL NOT BE PERMITTED AT THE TOP OF THE CYLINDER. STAKE WILL BE FLUSH WITH THE TOP OF THE CYLINDER.
6. MULCH WITHIN THE CYLINDER SHALL NOT EXCEED 3" DEPTH AND SHALL BE PULLED BACK FROM THE TRUNK AS SPECIFIED IN MULCH PLACEMENT DETAIL.
7. THE BOTTOM WHORL OF PINE AND LARCH BRANCHES MAY HAVE TO BE REMOVED TO PERMIT INSTALLATION OF 12" MIN. HEIGHT RODENT GUARDS.
8. INSTALL ON ALL DECIDUOUS, PINE AND LARCH TREES, DO NOT PLACE ON SPRUCE TREES.

RODENT PROTECTION

(MnDOT 2571.3I2)

1. USE SEAMLESS, EXTRUDED, TWIN-WALL, RIGID AND SEMI TRANSLUCENT POLYPROPYLENE TUBES WITH A LASER LINE PERFORATION AND AN OUTWARD-FLARED TOP RIM.
2. SECURE SHELTER WITH NYLON CABLE-TIES ATTACHED TO A 1" x 1" WHITE OAK STAKE TO PREVENT DISLODGING OR TWISTING.
3. EMBED THE BOTTOM OF THE TUBE A MINIMUM OF 1" BELOW THE SOIL SURFACE WITHOUT DISTURBING THE TREE ROOTS.
4. INSTALL A PLASTIC PHOTODEGRADABLE NETTING COVER AND SLEEVE OVER THE TOP OF THE TUBE. PULL NETTING DOWN AS SHOWN.

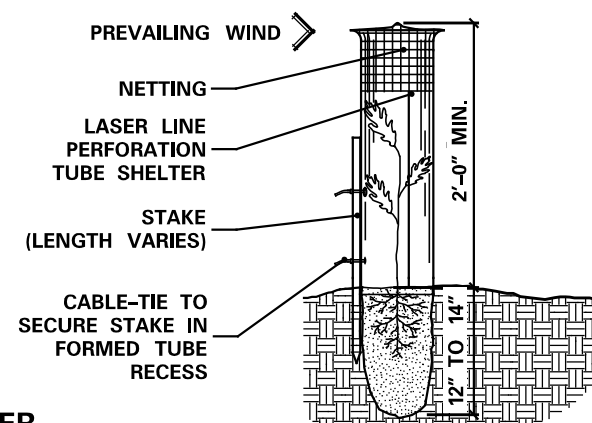

SEEDLING TREE SHELTER

(MnDOT 2571.3I4)

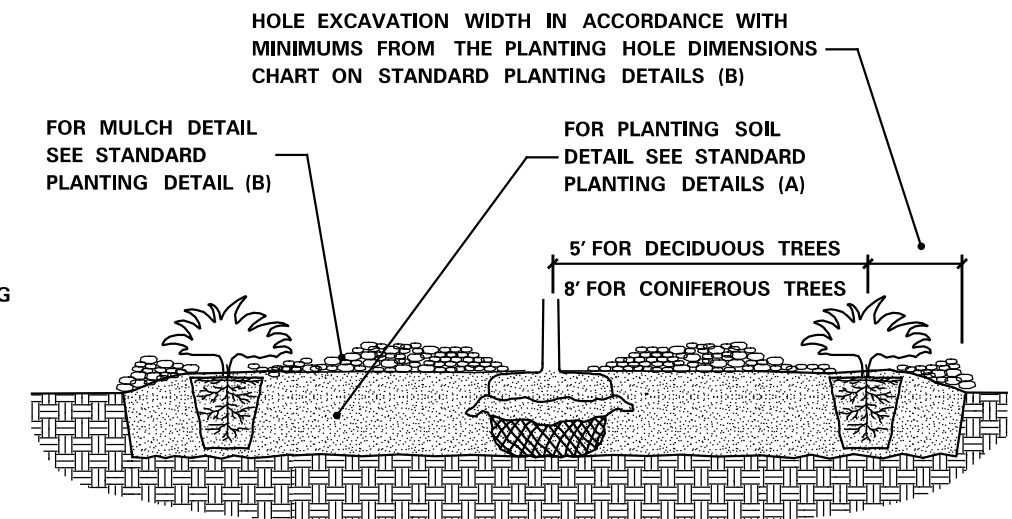

PLANT SPACING IN MASS BEDS

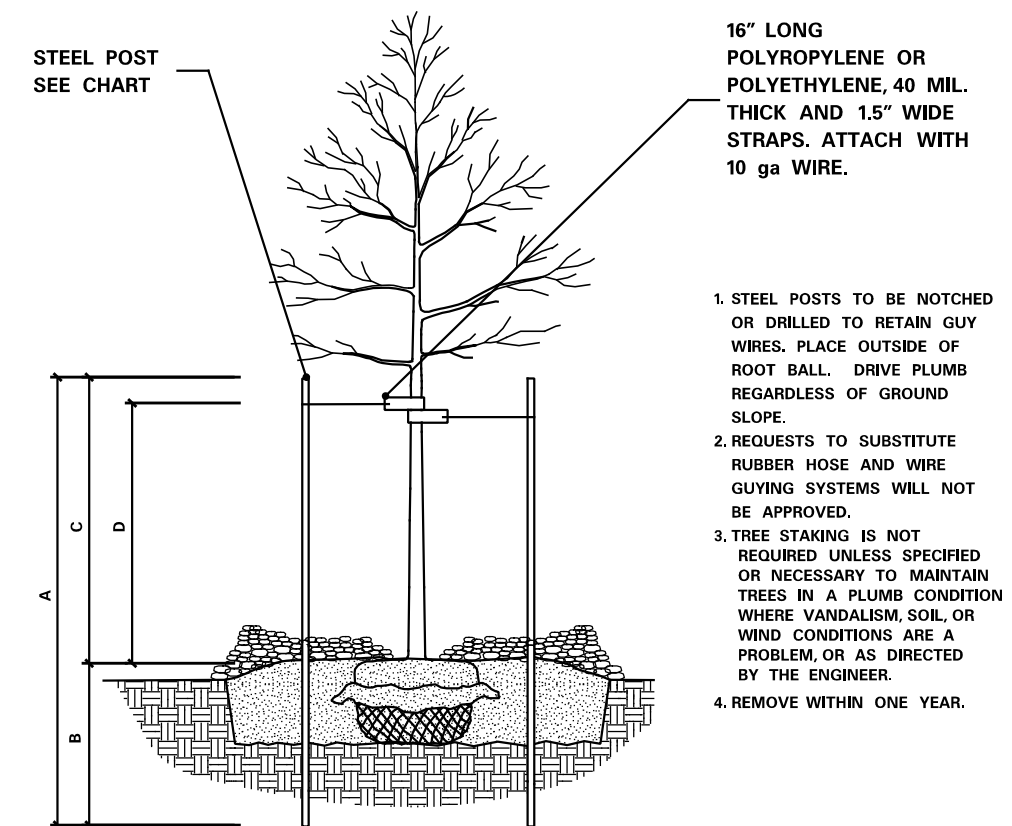

1. STEEL POSTS TO BE NOTCHED OR DRILLED TO RETAIN GUY WIRES. PLACE OUTSIDE OF ROOT BALL. DRIVE PLUMB REGARDLESS OF GROUND SLOPE.
2. REQUESTS TO SUBSTITUTE RUBBER HOSE AND WIRE GUYING SYSTEMS WILL NOT BE APPROVED.
3. TREE STAKING IS NOT REQUIRED UNLESS SPECIFIED OR NECESSARY TO MAINTAIN TREES IN A PLUMB CONDITION WHERE VANDALISM, SOIL, OR WIND CONDITIONS ARE A PROBLEM, OR AS DIRECTED BY THE ENGINEER.
4. REMOVE WITHIN ONE YEAR.

STEEL POST SIZING

CALIPER	STEEL POST TYPE	A	B	C	D
LESS THEN 4 INCHES	ROLLED STEEL FENCE POST (MnDOT 3403) OR APPROVED EQUAL.	7'-0"	3'-0" MIN.	4'-0"	3'-0"
GREATER THEN 4 INCHES	10', 2.2 LB. FLANGED CHANNEL STEEL SIGN POST (MnDOT 3401) OR APPROVED EQUAL.	10'-0"	4'-0" MIN.	6'-0"	5'-0"

STAKING AND GUYING

(MnDOT 2571.3I1)

GENERAL NOTES

- SEE SPECIAL PROVISIONS FOR SPECIFIC PROJECT REQUIREMENTS.
- REFER TO MnDOT SPECIFICATIONS 2571, 2572, 3861, FOR GENERAL REQUIREMENTS.
- COMPLETE PREPARATORY WORK BEFORE STARTING INITIAL PLANTING OPERATIONS.
- ACCEPT ALL PLANT STOCK IN ACCORDANCE WITH (MnDOT 3861) PRIOR TO PLANTING.
- THE CONTRACTOR WILL DEMONSTRATE COMPETENCY FOR SOIL CULTIVATION OPERATIONS IN ACCORDANCE WITH (MnDOT 2571.3D.2)
- THE CONTRACTOR WILL DEMONSTRATE COMPETENCY FOR ALL PLANT INSTALLATION OPERATIONS IN ACCORDANCE WITH (MnDOT 2571.3F1)

RODENT PROTECTION	SEE SPECIAL PROVISIONS AND STANDARD PLANTING DETAILS (3 OF 3)
FERTILIZER	SEE SPECIAL PROVISIONS
COMPOST	MnDOT 3890 COMPOST GRADE 2 UNLESS OTHERWISE SPECIFIED.
MULCH MATERIAL	MnDOT 3882 MULCH MATERIAL TYPE 6 UNLESS OTHERWISE SPECIFIED.
MASS PLANTING BEDS	PREPARE MASS PLANTING BEDS FOR PLANTS PLACED AT 15' OR LESS, UNLESS OTHERWISE SPECIFIED ON SHEETS. PLANT BEDS IN STAGGERED ROWS ON THE PERIMETER FIRST, THEN UNIFORMLY FILL IN WITH REMAINING PLANTS. USE TRIANGULAR SPACING, UNLESS SPECIFIED OTHERWISE. PROVIDE 5' RADIUS CLEAR OF SHRUBS AROUND EACH DECIDUOUS TREE AND 8' CLEAR RADIUS AROUND EACH CONIFER TREE. RADIUS WILL BE MEASURED FROM THE CENTER OF THE TREE TO THE CENTER OF THE SHRUB. NOTIFY ENGINEER OF GROSS PLANT QUANTITY SURPLUS OR DEFICIENCY IMMEDIATELY. MULCH ENTIRE MASS PLANTING BED. SEE STANDARD PLANTING DETAILS (3 OF 3)

TREE PAINTING (FROST CRACK PREVENTION)
 PAINT OAK, LINDEN, LOCUST, MAPLE, CRABAPPLE AND MOUNTAIN ASH. ONLY UNDILUTED EXTERIOR WHITE LATEX PAINT IS ACCEPTABLE. PAINT TREE CIRCUMFERENCE FROM GROUND LINE TO FIRST MAJOR BRANCH.

PLANTING PLAN DIMENSIONS
 STATED DIMENSIONS SUPERCEDE SCALING FROM PLAN.

WATERING GUIDELINES (MnDOT 2571.3G)	PLANT TYPE	AVERAGE GALLONS OF WATER PER APPLICATION
	MACHINE TRANSPLANTED TREES	50-100
	BALLED AND BURLAPPED TREES	20
	BARE ROOT AND CONTAINER TREES	15
	BALLED AND BURLAPPED SHRUBS	10
	BARE ROOT AND CONTAINER SHRUBS	7
	WOODY SEEDLINGS	4
PERENNIALS AND VINES	3	

IT IS THE CONTRACTOR'S RESPONSIBILITY TO MONITOR AND MAINTAIN SOIL MOISTURE AT ADEQUATE BUT NOT EXCESSIVE LEVELS. THE AMOUNTS LISTED ABOVE ARE GUIDELINES, NOT REQUIREMENTS.

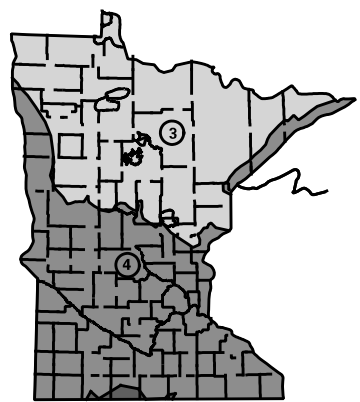

- BARE ROOT PERENNIALS MUST BE PLACED IN THE SPRING NO LATER THAN JUNE 1ST OR FOLLOW THE FALL DECIDUOUS PLANTING DATES.
- ACTUAL DATES MAY CHANGE DEPENDING UPON SEASONAL CONDITIONS, AS DETERMINED BY THE ENGINEER.
- FALL PLANTING IS NOT ALLOWED FOR BARE ROOT FORM OF THE FOLLOWING SPECIES: HAWTHORN, DOGWOOD, POPLAR, HACKBERRY, LINDEN, IRONWOOD, HONEYLOCUST, BIRCH, MOUNTAIN ASH, MAPLE, WILLOW, CRABAPPLE, PLUMCHERRY, OAKS, AND SUMAC.
- ALL REPLACEMENT PLANTS MUST BE PLACED DURING THE MONTH OF MAY (SPRING PLANTING) AND SEPTEMBER (FALL PLANTING) DURING THE FIRST YEAR OF THE PLANT ESTABLISHMENT PERIOD.
- MACHINE MOVED PLANTING DATES WILL BE SPECIFIED IN THE SPECIAL PROVISIONS.

PLANTING DATES BY ZONE

		③	④
SPRING	DECIDUOUS BARE ROOT	APRIL 21 TO JUNE 1	APRIL 7 TO JUNE 1
	CONTAINER B&B	APRIL 21 TO JUNE 30	APRIL 7 TO JUNE 30
	CONIFEROUS	APRIL 21 TO JUNE 1	APRIL 7 TO MAY 17
	PERENNIALS	MAY 1 TO JUNE 30	MAY 1 TO JUNE 30
	SEEDLINGS	APRIL 21 TO JUNE 1	APRIL 7 TO JUNE 1
FALL	DECIDUOUS BARE ROOT	OCT. 1 TO NOV. 1	OCT. 10 TO NOV. 15
	CONTAINER B&B	AUG. 25 TO OCT. 15	AUG. 25 TO NOV. 1
	CONIFEROUS	AUG. 25 TO SEPT. 15	AUG. 25 TO SEPT. 15
	PERENNIALS	AUG. 25 TO SEPT. 15	AUG. 25 TO SEPT. 15

PLANT INSTALLATION PERIOD

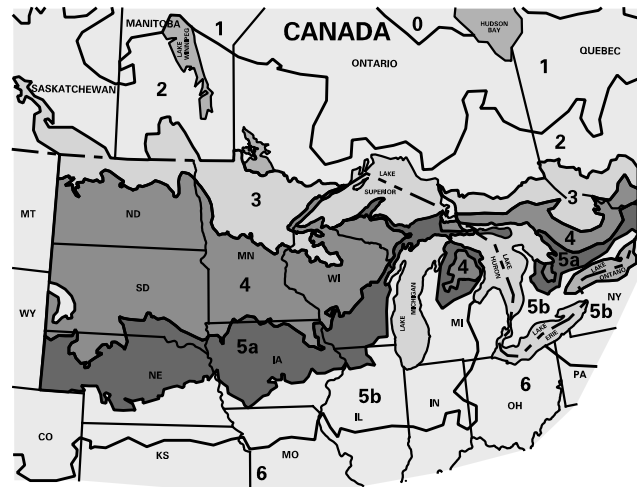

ZONES	LEGEND	MIN. TEMP.
3		-34.4° TO -40 F
4		-28.9° TO -34.4 F
5a		-26.1° TO -28.9 F

ZONES	LEGEND
0, 1, 2, 5b and 6	UNACCEPTABLE ZONES

FOR ALL PLANT STOCK, DOCUMENT ACCEPTABILITY FOR HARDINESS IN THE MINNESOTA ZONE WHERE THE PROJECT SITE IS LOCATED, AS FOLLOWS:

- A. PLANT STOCK CONTINUOUSLY GROWN FOR AT LEAST THE LAST TWO YEARS WITHIN THE ACCEPTABLE LIMITS SHOWN.
- OR
- B. PLANT STOCK, GROWN OUTSIDE THE ACCEPTABLE GROWING RANGE LIMITS, HAVING SEED SOURCE OR ROOT AND GRAFT STOCK ORIGINATING FROM THE ACCEPTABLE LIMITS SHOWN.

ACCEPTABLE PLANT STOCK GROWING RANGE LIMITS

SOURCE: USDA PLANT HARDINESS ZONE MAP (MnDOT 3861.2C)

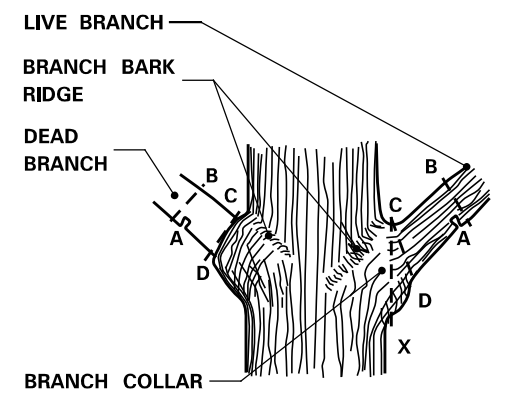

- STEPS TO PRUNING WITH PRUNING SAW:**
- CUT PART WAY THROUGH THE BRANCH AT POINT A.
 - CUT COMPLETELY THROUGH BRANCH FROM POINT B TO A.
 - AT BRANCH COLLAR CUT FROM POINT C TO D.

INCORRECT CUT FROM POINT C TO X (TOO CLOSE) WILL RESULT IN DISCONTINUOUS CALLUS FORMATION AFTER ONE SEASON OF GROWTH.

CORRECT CUT FROM POINT C TO D (LEAVING BRANCH COLLAR BUT NOT THE STUB FROM POINT B TO A) WILL RESULT IN CONTINUOUS DOUGHNUT SHAPED CALLUS FORMATION AFTER ONE SEASON OF GROWTH.

BRANCHES PRUNED AT TRUNK (SHIGO METHOD)

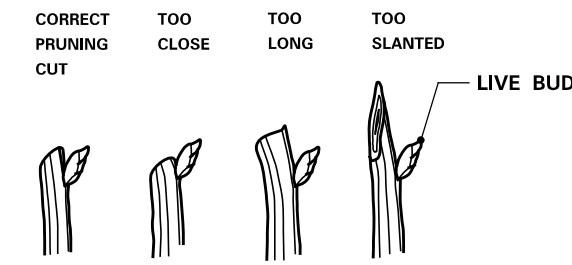

- PRUNING NOTES:**
- PRUNE USING CLEAN AND SHARP SCISSOR-TYPE PRUNER OR PRUNING SAW.
 - THE BEST TIME TO PRUNE IS LATE DORMANT SEASON OR EARLY SPRING.
 - AVOID PRUNING OAKS IN APRIL, MAY, JUNE OR JULY.
 - IF PRUNING IS NECESSARY OR IF WOUNDS OCCUR TO OAK TREES IN APRIL, MAY, JUNE OR JULY, IMMEDIATELY PAINT CUT SURFACE OR WOUND WITH LATEX PAINT OR SHELLAC.

BRANCHES PRUNED TO LIVE BUD

PRUNING

(MnDOT 2571.3E.1 and 2571.3K.2.a(9))

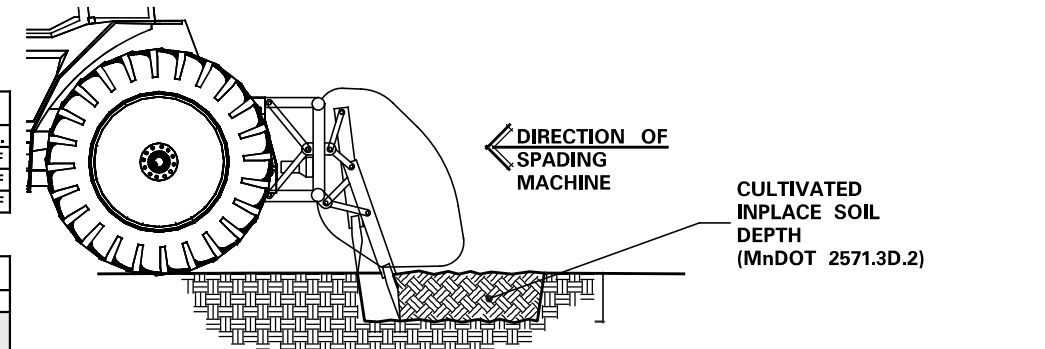

PRIMARY TILLAGE - PASS 1

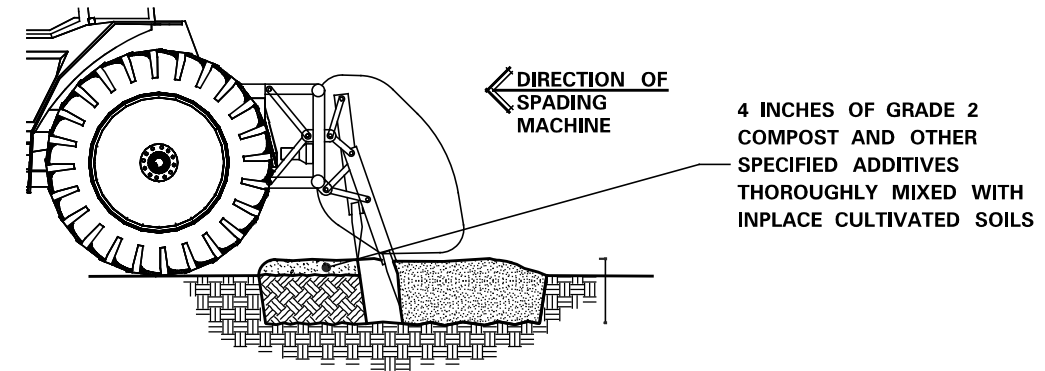

INCORPORATION TILLAGE - PASS 2

PLANTING SOIL

(MnDOT 2571.3D)

REVISION:
 APPROVED: DECEMBER 11, 2015
 [Signature]
 CHIEF ENVIRONMENTAL OFFICER

MINNESOTA DEPARTMENT OF TRANSPORTATION
 [Signature]
 STATE DESIGN ENGINEER
 APPROVED: 12-11-2015

STANDARD PLANTING DETAILS
 STANDARD PLAN 5-297.301
 1 OF 3

PLANTING HOLE DIMENSIONS

HOLE DEPTH FOR B&B AND CONTAINER PLANTS SHALL NOT EXCEED MEASUREMENT FROM ROOT FLAIR TO BOTTOM OF SOIL BALL.

PLANT TYPE	PLANT SIZE UP TO AND INCLUDING	(A) MINIMUM HOLE WIDTH	(B) APPROXIMATE HOLE DEPTH
DECIDUOUS & ORNAMENTAL TREES	3" B.R.	46"	13"
	4" B.R.	46"	14"
	5" B.R.	48"	14"
	6" B.R.	54"	15"
	7" B.R.	60"	16"
	8" B.R.	66"	19"
	0.75" B.B.	48"	12"
	1" B.B.	54"	14"
	1.25" B.B.	60"	14"
	1.5" B.B.	66"	15"
	1.75" B.B.	72"	16"
	2" B.B.	84"	19"
	4" B.B.	42"	11"
	5" B.B.	48"	12"
	6" B.B.	52"	14"
	8" B.B.	66"	16"
	10" B.B.	66"	16"
	12" B.B.	48"	16"
	1" B.B.	54"	14"
	1.25" B.B.	56"	15"
1.5" B.B.	61"	15"	
1.75" B.B.	66"	16"	
2" B.B.	72"	16"	
2.5" B.B.	84"	19"	
3" B.B.	96"	20"	
3.5" B.B.	114"	23"	
4" B.B.	126"	25"	
12" B.R.	24"	7"	
15" B.R.	28"	8"	
18" B.R.	30"	8"	
2" B.R.	33"	9"	
3" B.R.	42"	11"	
4" B.B.	48"	12"	
5" B.R.	54"	14"	
6" B.R.	60"	14"	
18" B.B.	27"	7"	
2" B.B.	30"	8"	
3" B.B.	36"	9"	
4" B.B.	42"	11"	
5" B.B.	48"	12"	
6" B.B.	54"	14"	
DECIDUOUS SHRUBS, ROSES AND PERENNIALS	2" B.R.	33"	9"
	3" B.R.	42"	11"
PERENNIAL HOLE DEPTH AND WIDTH SHALL BE BASED UPON ON-CENTER SPACING IN A CONTINUOUS TRENCH.	4" B.B.	48"	12"
	5" B.R.	54"	14"
	6" B.R.	60"	14"
	18" B.B.	27"	7"
	2" B.B.	30"	8"
	3" B.B.	36"	9"

PLANTING HOLE DIMENSIONS

HOLE DEPTH FOR B&B AND CONTAINER PLANTS SHALL NOT EXCEED MEASUREMENT FROM ROOT FLAIR TO BOTTOM OF SOIL BALL.

PLANT TYPE	PLANT SIZE UP TO AND INCLUDING	(A) MINIMUM HOLE WIDTH	(B) APPROXIMATE HOLE DEPTH
CONIFEROUS TREES	2" B.B.	36"	10"
	3" B.B.	42"	11"
	4" B.B.	51"	13"
	5" B.B.	60"	13"
	6" B.B.	66"	15"
	7" B.B.	72"	16"
	8" B.B.	81"	18"
	9" B.B.	90"	20"
	10" B.B.	102"	21"
	12" B.B.	114"	24"
18" B.B.	24"	7"	
3" B.B.	48"	12"	
CONIFEROUS SHRUBS (UPRIGHT)			
CONIFEROUS SHRUBS (SPREADING)			
18" SPR B.B.	30"	8"	
2" SPR B.B.	36"	9"	
CONTAINER GROWN PLANTS	CELLPACKS / PLUGS	6"	2.5"
	2.25" CONT.	7"	3"
	3.5" CONT.	10"	3"
	4" CONT.	11"	4"
	4.5" CONT.	13"	4"
	6" 1 QT CONT.	15"	5.5"
	1# CONT.	18"	6"
	2# CONT.	23"	7.5"
	3# CONT.	29"	8.5"
	5# CONT.	30"	11"
	7# CONT.	37"	11"
	15# CONT.	44"	14"
	10# CONT.	45"	15"
	20# CONT.	60"	16"
	25# CONT.	72"	17"
SEEDLINGS	6" SEEDLING	15"	14"
	9" SEEDLING	18"	14"
	12" SEEDLING	23"	16"
	18" SEEDLING	30"	16"
	2" SEEDLING	36"	18"
VINES	1 YR. MED. B.R.	15"	11"
	1 YR. NO. 1 B.R.	17"	14"
	2 YR. MED. B.R.	33"	12"
2 YR. NO. 1 B.R.	42"	15"	

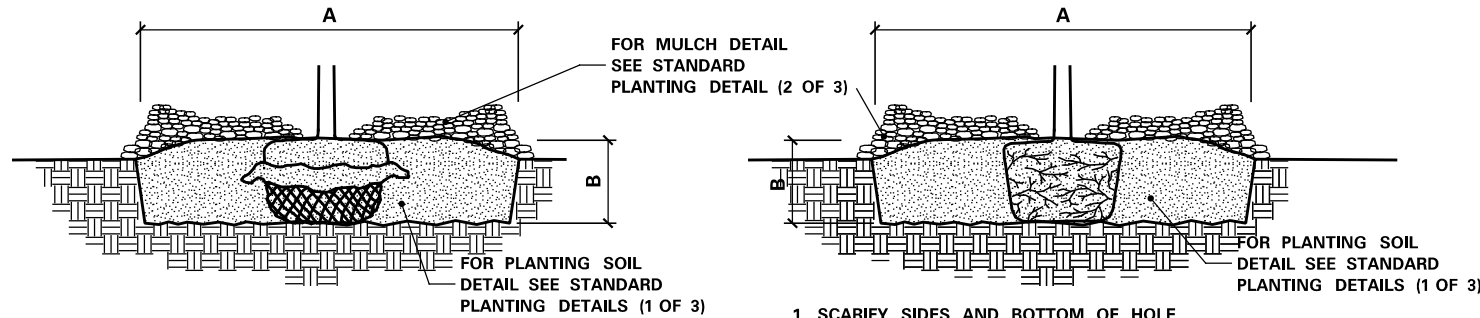

1. SCARIFY SIDES AND BOTTOM OF HOLE.
2. PROCEED WITH CORRECTIVE PRUNING.
3. SET PLANT ON UNDISTURBED NATIVE SOIL OR THOROUGHLY COMPACTED PLANTING SOIL. PLACE PLANT SO THE ROOT FLARE IS AT OR UP TO 2" ABOVE THE FINISHED GRADE WITH BURLAP AND WIRE BASKET, (IF USED), INTACT.
4. SLIT REMAINING TREATED BURLAP AT 6" INTERVALS.
5. BACKFILL TO WITHIN APPROXIMATELY 12" OF THE TOP OF THE ROOTBALL, THEN WATER PLANT.
6. REMOVE THE TOP 1/3 OF THE BASKET OR THE TOP TWO HORIZONTAL RINGS WHICHEVER IS GREATER. REMOVE ALL BURLAP AND NAILS FROM THE TOP 1/3 OF THE BALL. REMOVE ALL TWINE. REMOVE OR CORRECT STEM GIRDLING ROOTS.
7. PLUMB AND BACKFILL WITH PLANTING SOIL.
8. WATER THOROUGHLY WITHIN 2 HOURS TO SETTLE PLANTS AND FILL VOIDS.
9. BACK FILL VOIDS AND WATER A SECOND TIME.
10. PLACE MULCH WITHIN 48 HOURS OF THE SECOND WATERING UNLESS SOIL MOISTURE IS EXCESSIVE.

1. SCARIFY SIDES AND BOTTOM OF HOLE.
2. PROCEED WITH CORRECTIVE PRUNING OF TOP AND ROOT.
3. REMOVE CONTAINER AND SCORE OUTSIDE OF SOIL MASS TO REDIRECT AND PREVENT CIRCLING FIBROUS ROOTS. REMOVE OR CORRECT STEM GIRDLING ROOTS.
4. SET PLANT ON UNDISTURBED NATIVE SOIL OR THOROUGHLY COMPACTED PLANTING SOIL. INSTALL PLANT SO THE TOP OF THE ROOT FLARE IS AT OR UP TO 2" ABOVE THE FINISHED GRADE.
5. PLUMB AND BACKFILL WITH PLANTING SOIL.
6. WATER THOROUGHLY WITHIN 2 HOURS TO SETTLE PLANT AND FILL VOIDS.
7. BACK FILL VOIDS AND WATER A SECOND TIME.
8. PLACE MULCH WITHIN 48 HOURS OF THE SECOND WATERING UNLESS SOIL MOISTURE IS EXCESSIVE.

CONTAINER STOCK

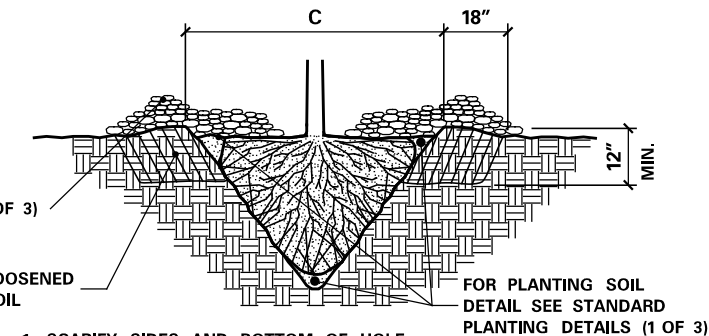

1. SCARIFY SIDES AND BOTTOM OF HOLE.
2. PROCEED WITH CORRECTIVE PRUNING.
3. SET PLANT ON NATIVE SOIL AT SAME DEPTH AS IT WAS PREVIOUSLY GROWN.
4. PLUMB AND BACKFILL WITH PLANTING SOIL.
5. AFTER PLANTING, LOOSEN THE SOIL IMMEDIATELY ADJACENT TO THE ROOT BALL TO A MINIMUM DISTANCE OF 18" AND A MINIMUM DEPTH OF 12".
6. WATER THOROUGHLY WITHIN 2 HOURS TO SETTLE PLANT AND FILL VOIDS.
7. BACK FILL VOIDS AND WATER A SECOND TIME.
8. PLACE MULCH WITHIN 48 HOURS OF THE SECOND WATERING UNLESS SOIL MOISTURE IS EXCESSIVE.

MINIMUM TREE SPADE SIZE REQUIREMENTS

(C) SPADE DIAMETER SIZE	OAK TREE, CALIPER	DECIDUOUS / ORNAMENTAL TREE, CALIPER	CONIFEROUS TREE, HEIGHT
42"	1" to 1.5"	2" to 3"	5' to 7'
60"	1.5" to 2.5"	3" to 4"	7' to 9'
78"	2.5" to 3.5"	4" to 6"	9' to 14'
85"	3.5" to 5"	6" to 8"	14' to 18'

BALLED & BURLAPPED STOCK

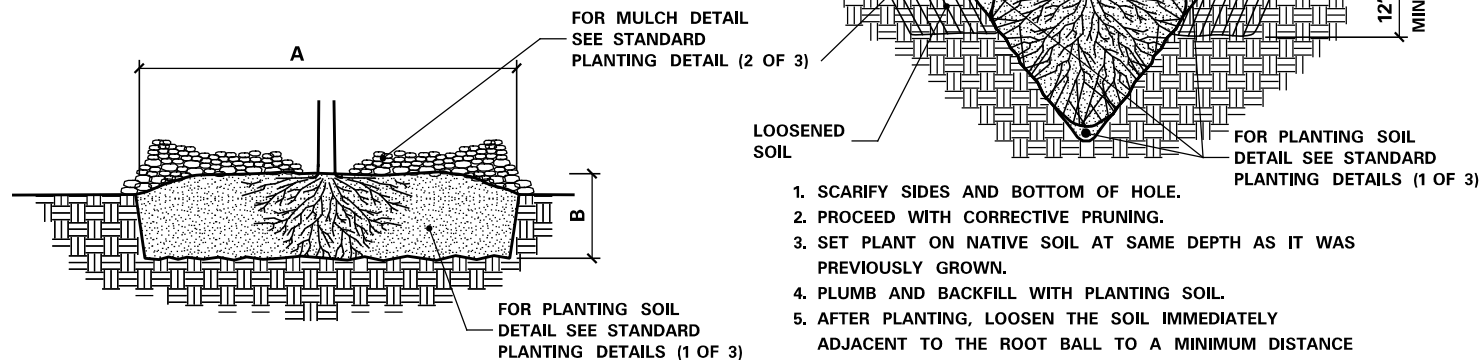

1. SOAK ROOTS IN WATER FOR AT LEAST ONE HOUR BUT NOT MORE THAN 24 HOURS PRIOR TO PLANTING.
2. SCARIFY SIDES AND BOTTOM OF HOLE.
3. PROCEED WITH CORRECTIVE PRUNING OF THE TOP AND ROOTS.
4. TRANSFER PLANT DIRECTLY FROM WATER TO HOLE. SET PLANT SO THE ROOT FLARE IS AT THE FINISHED SOIL ELEVATION. SPREAD ROOTS OUT EVENLY. PLUMB AND IMMEDIATELY BACKFILL WITH PLANTING SOIL.
5. WATER THOROUGHLY WITHIN 2 HOURS TO SETTLE PLANTS AND FILL VOIDS.
6. BACK FILL VOIDS AND WATER A SECOND TIME.
7. PLACE MULCH WITHIN 48 HOURS OF THE SECOND WATERING UNLESS SOIL MOISTURE IS EXCESSIVE.

**BARE ROOT STOCK
INSTALLATION OF PLANTS**

MACHINE MOVED STOCK

MULCH AREA CALCULATOR

TYPE OF PLANT	SQ. FT. PER PLANT
CONIFEROUS TREES	$\left[\left(\frac{3}{5} \times \text{HEIGHT}\right) + 3\right]^2 \times \pi$
DECIDUOUS AND ORNAMENTAL TREES	$3^2 \times \pi$
CONIFEROUS AND DECIDUOUS SHRUBS, ROSE BUSHES, PERENNIALS, ORNAMENTAL GRASS	SPACING x SPACING
VINES	SPACING x 2
MACHINE-MOVED TREES OR SHRUBS	$\left[\left(\frac{\text{SPADE DIAMETER}}{2}\right) + 1\right]^2 \times \pi$

$\pi = 3.1416$

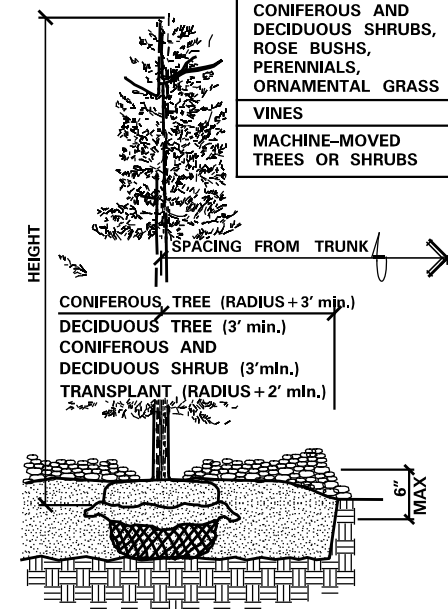

1. PULL MULCH BACK NO LESS THAN 3" AND NO MORE THAN 6" FROM TREES AND SHRUBS AT THE TRUNK OR MAIN STEM.
2. SUBSIDING OR DETERIORATING MULCH IS ACCEPTABLE THROUGHOUT THE ESTABLISHED PERIOD IF THE MULCH DEPTH IS MAINTAINED AT A MINIMUM 3" DEPTH.
3. ADD MULCH WHEN BELOW THE 3" MINIMUM DEPTH; DO NOT EXCEED THE 6" MAXIMUM DEPTH.
4. MULCH CONTAMINATED WITH SOIL MUST BE REMOVED AND REPLACED.

MULCH

(MnDOT 2571.3H)

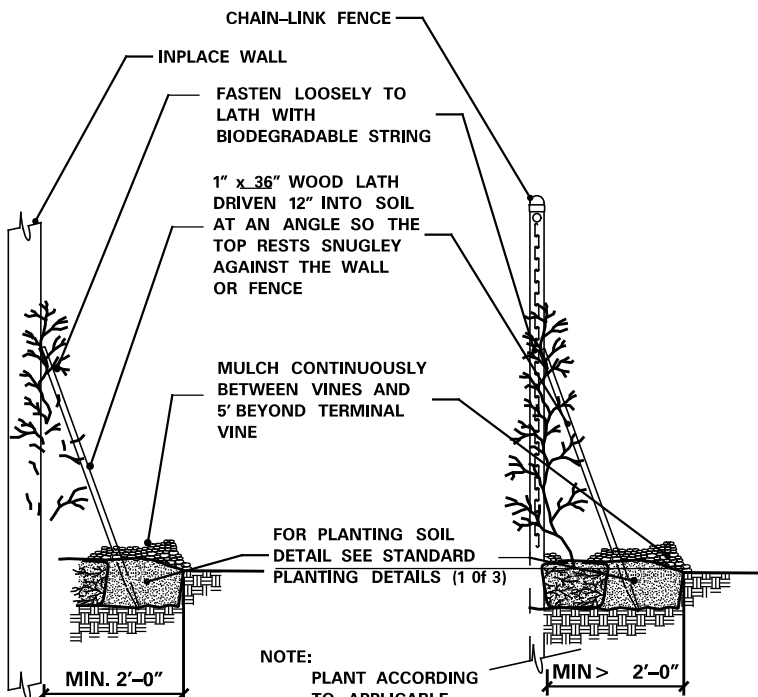

WALL INSTALLATION FENCE INSTALLATION

INSTALLATION OF VINES

REVISION:
APPROVED: DECEMBER 11, 2015
[Signature]
CHIEF ENVIRONMENTAL OFFICER

MINNESOTA DEPARTMENT OF TRANSPORTATION
[Signature]
STATE DESIGN ENGINEER

REVISED:
APPROVED:
12-11-2015

(MnDOT 2571.3F)

STANDARD PLANTING DETAILS

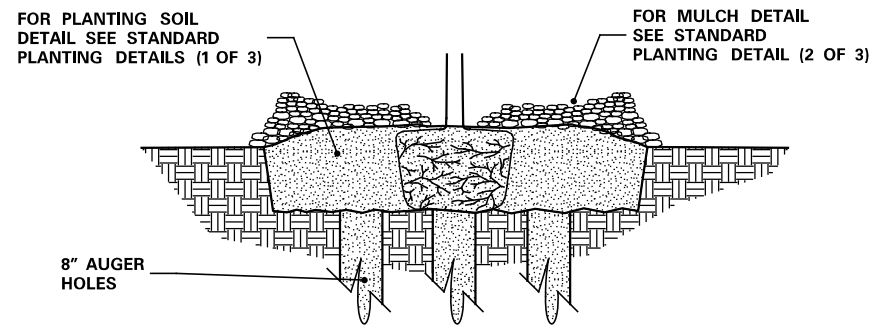

- EXCAVATE HOLE OR BED TO ALLOW PLACING THE TOP OF ROOT MASS 1"-3" HIGHER THAN FINISHED GRADE.
- AUGER 8" DIAMETER HOLES ENTIRELY THROUGH IMPERVIOUS OR POORLY DRAINED HARD PAN SOIL LAYER TO ADEQUATELY DRAIN SUBSOIL.
- TEST FOR POSITIVE DRAINAGE. RE-AUGER AN ADDITIONAL 8" IF NECESSARY FOR POSITIVE DRAINAGE.
- THOROUGHLY BACKFILL AUGER HOLES WITH A UNIFORM INCORPORATED MIXTURE OF 50% SAND AND 50% INPLACE SOIL.
- COMPLETE PLANTING ACCORDING TO ROOT TYPE. SEE STANDARD PLANTING DETAILS (2 OF 3).

GRANULAR FILTER

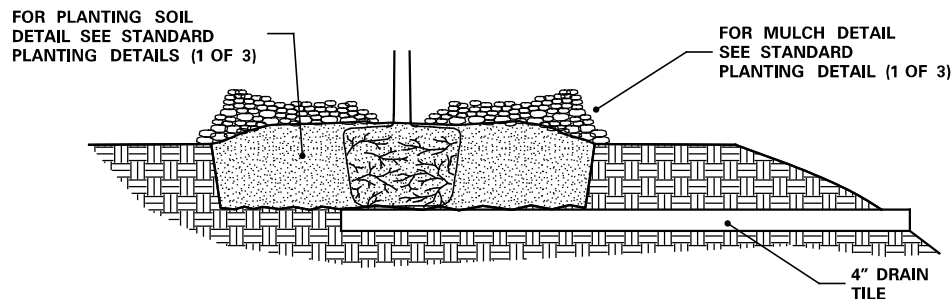

- EXCAVATE HOLE OR BED TO ALLOW PLACING THE TOP OF THE ROOT MASS 1"-3" HIGHER THAN FINISHED GRADE.
- INSTALL 4" MINIMUM DIAMETER DRAIN TILE DAYLIGHTING AT A LOWER GRADE.
- COMPLETE PLANTING ACCORDING TO ROOT TYPE. SEE STANDARD PLANTING DETAILS (2 OF 3).

TILE DRAINAGE

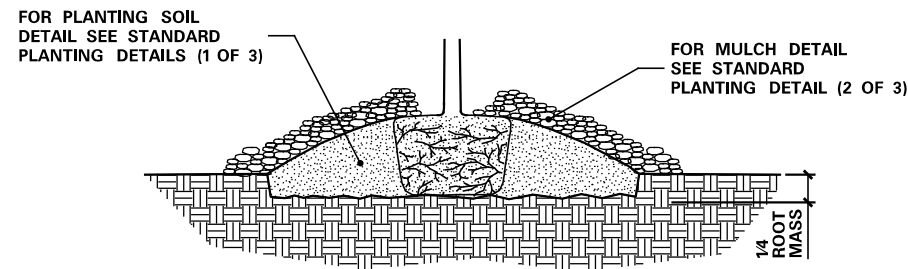

- EXCAVATE HOLE OR BED 1/4 THE DEPTH OF THE ROOT MASS.
- SET ROOT MASS IN HOLE.
- CONSTRUCT BERM WITH PLANTING SOIL. EXTEND THE BERM BASE TO A WIDTH OF 3 TIMES THE BERM HEIGHT.
- COMPLETE PLANTING ACCORDING ROOT TYPE. SEE STANDARD PLANTING DETAILS (2 OF 3).

MINI-BERM

NOTE:

- THE NEED FOR USING PLANTING DETAILS FOR POORLY DRAINED SOILS AND WHICH TYPE TO USE ARE DETERMINED BY THE CONTRACTOR, SUBJECT TO ENGINEER APPROVAL.

PLANTING DETAIL FOR POORLY DRAINED SOILS

(MnDOT 2571.3D.2(8))

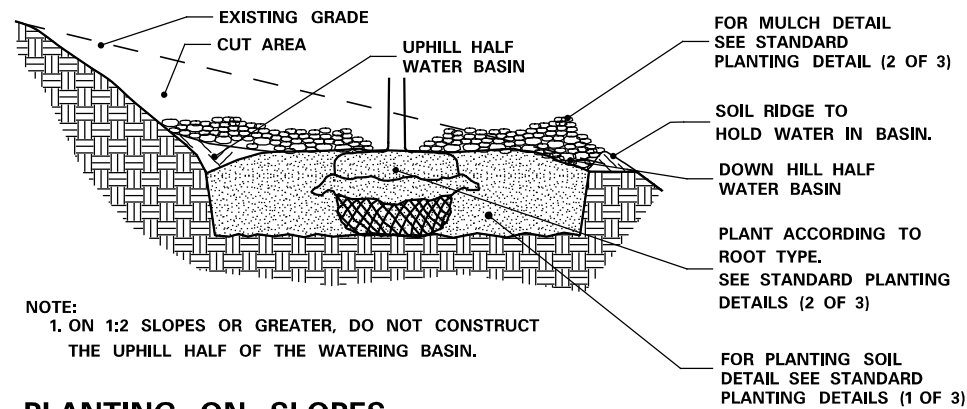

PLANTING ON SLOPES

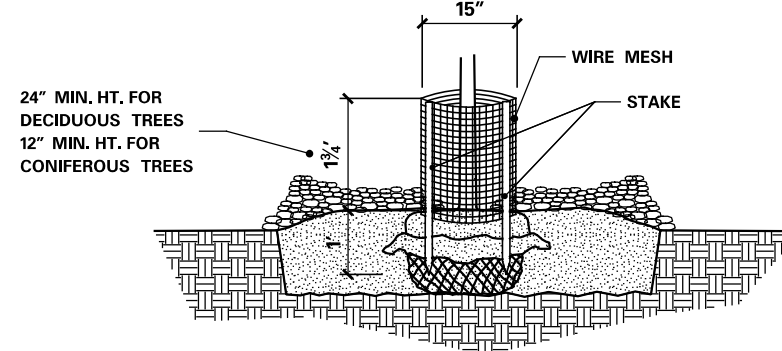

- FORM A DOUBLE-LAYERED CYLINDER USING 0.25" GRID GALVANIZED WELDED WIRE MESH (HARDWARE CLOTH). OVERLAP THE CUT END 2".
- DRIVE TWO 1" x 1" OPPOSING HEARTWOOD WHITE OAK STAKES INTO THE GROUND, 7" FROM THE CENTER OF THE TREE STEM.
- SECURE THE MESH CYLINDER TO THE OUTSIDE OF THE STAKES USING EITHER, SCREWS AND WASHERS OR CABLE-TIES ALONG THE OVERLAP. SPACE APPROXIMATELY 4" ON CENTER ALONG THE OVERLAP.
 - SCREWS SHALL BE ROUND HEAD GALVANIZED 18" DIA. x 3/4" LONG WITH WASHERS.
 - OR
 - CABLE-TIES SHALL BE NYLON, AT LEAST 8" LONG AND BETWEEN 75LB TO 120LB TENSILE STRENGTH.
- EMBED THE LOWER EDGE OF THE MESH CYLINDER 1" BELOW THE SOIL SURFACE WITHOUT DISTURBING THE TREE ROOTS.
- CUT EDGES WILL NOT BE PERMITTED AT THE TOP OF THE CYLINDER. STAKE WILL BE FLUSH WITH THE TOP OF THE CYLINDER.
- MULCH WITHIN THE CYLINDER SHALL NOT EXCEED 3" DEPTH AND SHALL BE PULLED BACK FROM THE TRUNK AS SPECIFIED IN MULCH PLACEMENT DETAIL.
- THE BOTTOM WHORL OF PINE AND LARCH BRANCHES MAY HAVE TO BE REMOVED TO PERMIT INSTALLATION OF 12" MIN. HEIGHT RODENT GUARDS.
- INSTALL ON ALL DECIDUOUS, PINE AND LARCH TREES, DO NOT PLACE ON SPRUCE TREES.

RODENT PROTECTION

(MnDOT 2571.3I.2)

- USE SEAMLESS, EXTRUDED, TWIN-WALL, RIGID AND SEMI TRANSLUCENT POLYPROPYLENE TUBES WITH A LASER LINE PERFORATION AND AN OUTWARD-FLARED TOP RIM.
- SECURE SHELTER WITH NYLON CABLE-TIES ATTACHED TO A 1" x 1" WHITE OAK STAKE TO PREVENT DISLODGING OR TWISTING.
- EMBED THE BOTTOM OF THE TUBE A MINIMUM OF 1" BELOW THE SOIL SURFACE WITHOUT DISTURBING THE TREE ROOTS.
- PLACE A PLASTIC PHOTODEGRADABLE NETTING COVER AND SLEEVE OVER THE TOP OF THE TUBE. PULL NETTING DOWN AS SHOWN.

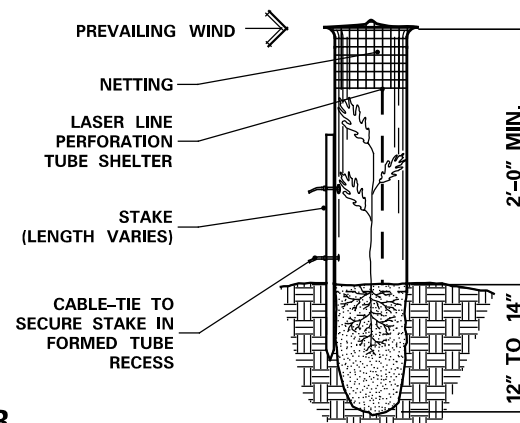

SEEDLING TREE SHELTER

(MnDOT 2571.3I.4)

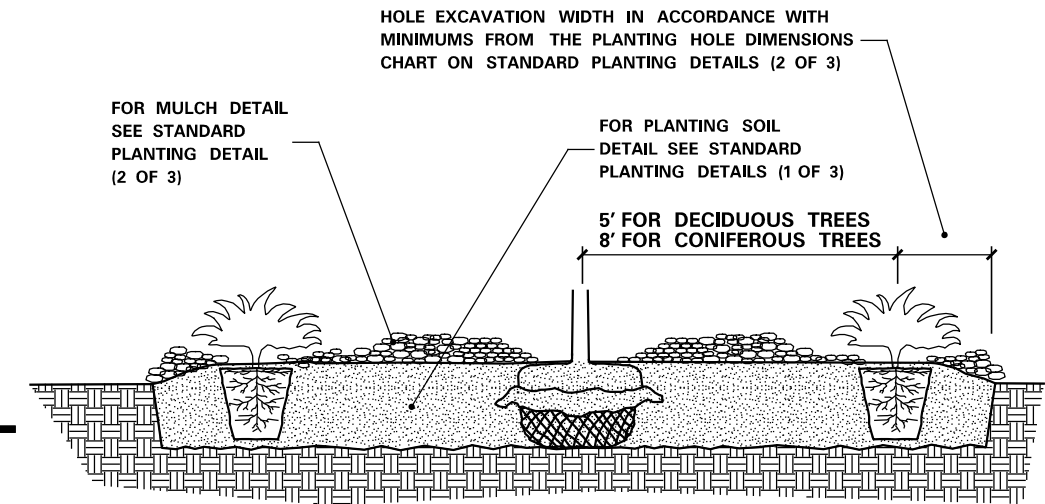

PLANT SPACING IN MASS BEDS

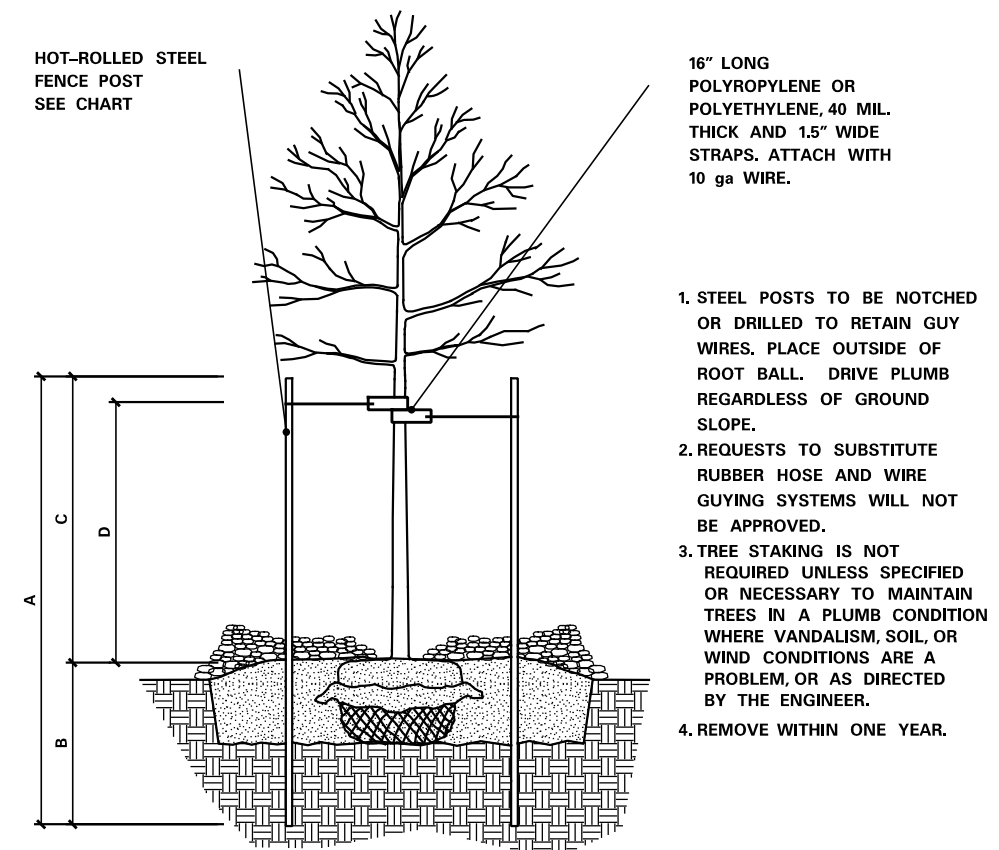

- STEEL POSTS TO BE NOTCHED OR DRILLED TO RETAIN GUY WIRES. PLACE OUTSIDE OF ROOT BALL. DRIVE PLUMB REGARDLESS OF GROUND SLOPE.
- REQUESTS TO SUBSTITUTE RUBBER HOSE AND WIRE GUYING SYSTEMS WILL NOT BE APPROVED.
- TREE STAKING IS NOT REQUIRED UNLESS SPECIFIED OR NECESSARY TO MAINTAIN TREES IN A PLUMB CONDITION WHERE VANDALISM, SOIL, OR WIND CONDITIONS ARE A PROBLEM, OR AS DIRECTED BY THE ENGINEER.
- REMOVE WITHIN ONE YEAR.

STEEL POST SIZING

CALIPER	STEEL POST TYPE	A	B	C	D
LESS THAN 4 INCHES	HOT-ROLLED STEEL FENCE POST (MnDOT 3403) OR APPROVED EQUAL.	7'-0"	3'-0" MIN.	4'-0"	3'-0"
GREATER THAN 4 INCHES	10' 2.2 LB. FLANGED CHANNEL SIGN POST (MnDOT 3401) OR APPROVED EQUAL.	10'-0"	4'-0" MIN.	6'-0"	5'-0"

STAKING AND GUYING

(MnDOT 2571.3I.1)

REVISIONS:
APPROVED: DECEMBER 11, 2015
[Signature]
CHIEF ENVIRONMENTAL OFFICER

REVISIONS:
[Signature]
STATE DESIGN ENGINEER
APPROVED: 12-11-2015

STANDARD PLANTING DETAILS

STANDARD PLAN 5-297.301

3 OF 3

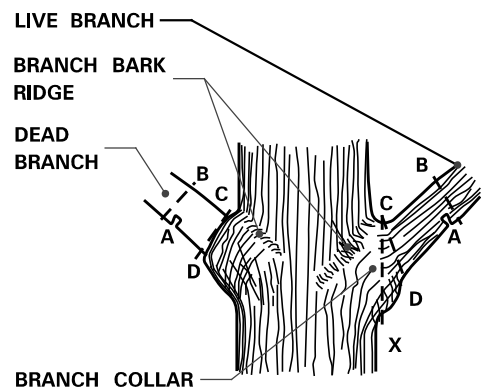

- STEPS TO PRUNING WITH PRUNING SAW:**
1. CUT PART WAY THROUGH THE BRANCH AT POINT A.
 2. CUT COMPLETELY THROUGH BRANCH FROM POINT B TO A.
 3. AT BRANCH COLLAR CUT FROM POINT C TO D.

INCORRECT CUT FROM POINT C TO X (TOO CLOSE) WILL RESULT IN DISCONTINUOUS CALLUS FORMATION AFTER ONE SEASON OF GROWTH.

CORRECT CUT FROM POINT C TO D (LEAVING BRANCH COLLAR BUT NOT THE STUB FROM POINT B TO A) WILL RESULT IN CONTINUOUS DOUGHNUT SHAPED CALLUS FORMATION AFTER ONE SEASON OF GROWTH.

BRANCHES PRUNED AT TRUNK (SHIGO METHOD)

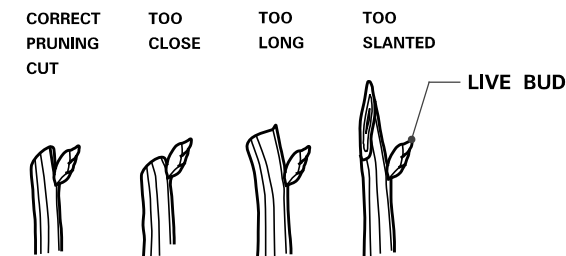

- PRUNING NOTES:**
1. PRUNE USING CLEAN AND SHARP SCISSOR-TYPE PRUNER OR PRUNING SAW.
 2. THE BEST TIME TO PRUNE IS LATE DORMANT SEASON OR EARLY SPRING.
 3. AVOID PRUNING OAKS IN APRIL, MAY, JUNE OR JULY.
 4. IF PRUNING IS NECESSARY OR IF WOUNDS OCCUR TO OAK TREES IN APRIL, MAY, JUNE OR JULY, IMMEDIATELY PAINT CUT SURFACE OR WOUND WITH LATEX PAINT OR SHELLAC.

BRANCHES PRUNED TO LIVE BUD

PRUNING

(MnDOT 2571.3E.1 and 2571.3K.2.a(9))

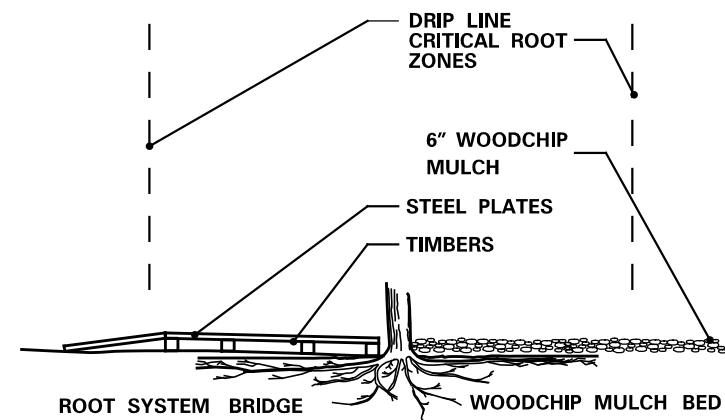

IF CONSTRUCTION VEHICLES MUST PASS OVER ROOT ZONES, THE CONTRACTOR MUST EITHER:

1. CONSTRUCT ROOT SYSTEM BRIDGES WITH STEEL PLATE SUPPORTED ON WOOD TIMBERS PLACED RADIALLY TO THE TREE TRUNK.
- OR
2. PLACE A 6 INCH LAYER OF WOODCHIP MULCH OVER A TYPE III GEOTEXTILE (MnDOT 3733).

OTHER VEGETATION PROTECTION MEASURES

(MnDOT 2572.3A.12)

1. FABRICATE 12" X 9" X 3/8" SIGN WITH 0.75" RADIUS CORNERS.
2. SIGN SHALL BE WHITE WITH BLACK LETTERING.
3. ATTACH SIGN TO POST USING 1" LENGTH WOOD SCREWS.

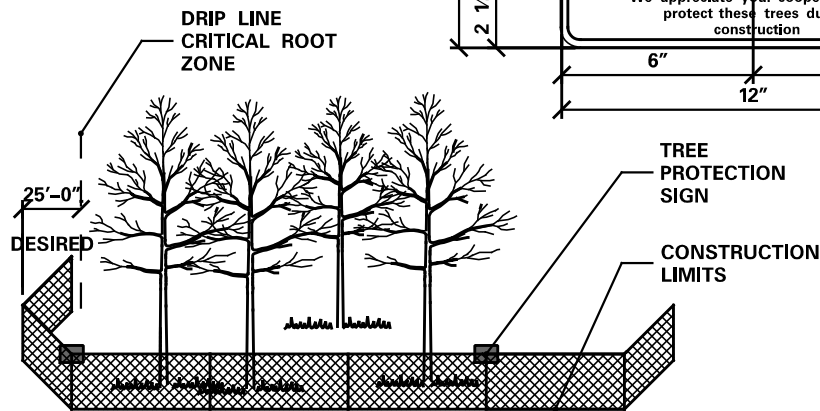
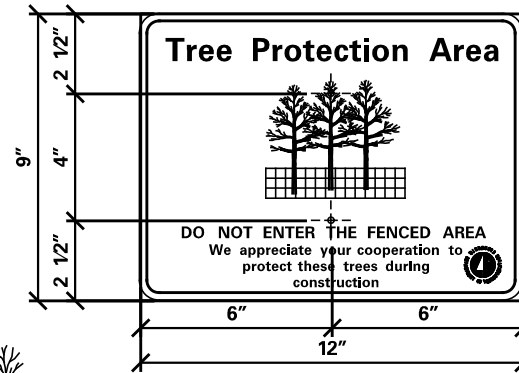

1. FURNISH AND INSTALL TEMPORARY FENCE AT THE TREE'S DRIFLINE OR CONSTRUCTION LIMITS AS SPECIFIED, PRIOR TO ANY CONSTRUCTION.
2. WHEN POSSIBLE PLACE FENCE 25 FEET BEYOND THE DRIP LINE.
3. PLACE TREE PROTECTION SIGNS ALONG FENCE AT 50' INTERVALS.

TEMPORARY FENCE

(MnDOT 2572.3A.1)

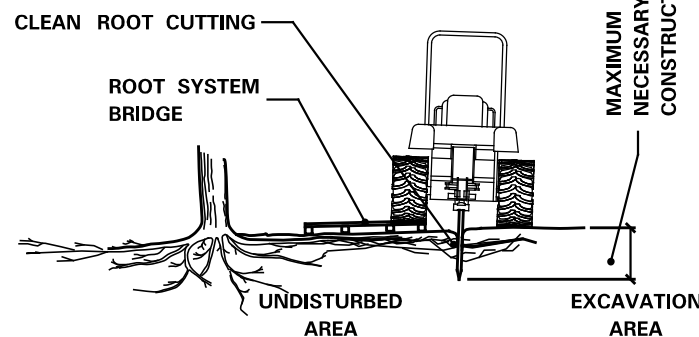

1. WHEN DESIGNATED IN THE PLAN OR DIRECTED BY THE ENGINEER, PRIOR TO EXCAVATION, ALL TREE ROOTS WILL BE CLEANLY CUT BY A VIBRATORY PLOW OR OTHER APPROVED ROOT CUTTER.
2. THE TREE ROOTS WILL BE CUT CLEANLY TO THE MINIMUM DEPTH NECESSARY FOR CONSTRUCTION.
3. IMMEDIATELY, AND CLEANLY CUT DAMAGED AND EXPOSED ROOTS.
4. ROOT ENDS EXPOSED BY EXCAVATION ACTIVITIES SHALL BE IMMEDIATELY COVERED WITH A 6" LAYER OF ADJACENT SOIL.
5. EXPOSED CUT OAK ROOTS SHALL BE IMMEDIATELY (WITHIN 5 MINUTES) TREATED WITH A WOUND DRESSING MATERIAL CONSISTING OF LATEX PAINT OR SHELLAC.

CLEAN ROOT CUTTING

(MnDOT 2572.3A.2)

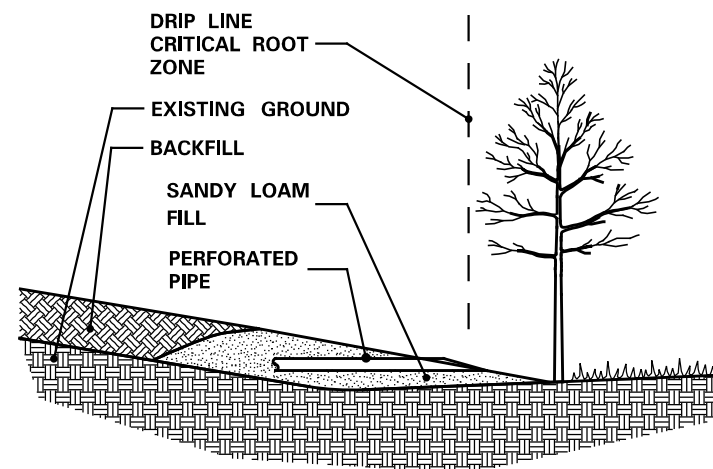

1. ANY FILL REQUIRED WITHIN THE DRIP LINE OF TREES, IS UNCOMPACTED ROOTING TOPSOIL BORROW.
2. EXCESSIVE FILL MAY REQUIRE PLACING PERFORATED PIPE WITH AT LEAST ONE DAYLIGHTED END OPENING AS AN AERATION SYSTEM.

ROOTING TOPSOIL BORROW

(MnDOT 2572.3A.4)

UTILITY CONSTRUCTION

(MnDOT 2572.3A.5)

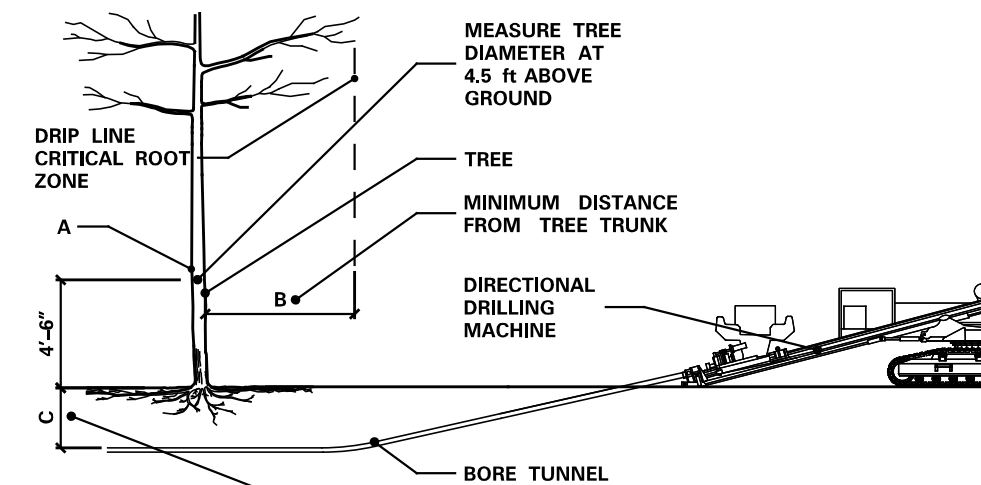

NOTE:

1. (A) IS THE DIAMETER OF TREES MEASURED 4'-6" FEET ABOVE THE GROUND AND IS TERMED THE "DIAMETER AT BREAST HEIGHT," (DBH).
2. USING A TREE DIAMETER TAPE, WRAP THE TAPE AROUND THE GIRTH OF THE TREE, AT THE DBH, BEING CAREFUL NOT TO TWIST THE TAPE.

TREE PROTECTION ZONE		
A	B	C
< 2"	2'	2'
2-4"	4'	2.5'
> 4-9"	6'	2.5'
> 9-14"	10'	3'
> 14-19"	12'	3.25'
> 19"	15'	4'

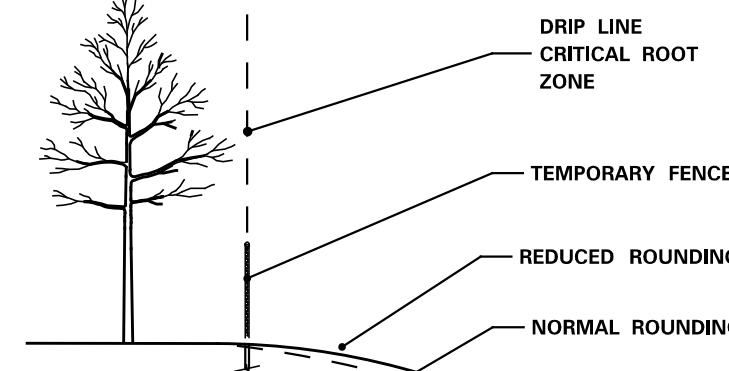

SIGNIFICANT TREES NEAR THE PROPOSED CONSTRUCTION LIMITS WILL BE IDENTIFIED IN THE PLAN OR BY THE ENGINEER AND WILL BE PRESERVED BY THE CONTRACTOR.

1. PLACE THE TEMPORARY FENCE.
2. REDUCE SLOPE ROUNDING WHERE ROOT ZONES ARE DISTURBED BY NORMAL SLOPE ROUNDING.
3. VARY BACKSLOPE STEEPNESS TO AVOID TREE LOSS OR UNNECESSARY ROOT DAMAGE.

SLOPE ROUNDING

REVISION:
APPROVED: DECEMBER 11, 2015
[Signature]
CHIEF ENVIRONMENTAL OFFICER

MINNESOTA DEPARTMENT OF TRANSPORTATION
[Signature]
STATE DESIGN ENGINEER

REVISED:
APPROVED:
12-11-2015

PROTECTION AND RESTORATION OF VEGETATION

STANDARD PLAN 5-297.302

1 OF 1

2571 PLANT INSTALLATION AND ESTABLISHMENT

2571.1 DESCRIPTION

This Work consists of providing, installing, and establishing trees, shrubs, vines, perennials, and turf of the species, variety, grade, size or age, and root category specified for the locations shown on the Plans, including planting or transplanting plants provided by the Department.

Perform this Work in accordance with the *Inspection and Contract Administration Manual for MnDOT Landscape Projects (ICAMMLP)*, current edition at the time of letting.

2571.2 MATERIALS

A Nursery Plant Stock 3861
Provide plants of the species shown on the Plans in the variety, grade, and size or age indicated.

A.1 Investigations and Supply of Planting Stock and Materials

By submitting a proposal and accepting Award of the Contract in accordance with 1205, "Examination of Proposal Package and Site of Work," the Contractor assures commitments from suppliers, and delivery of the plant stock and Materials required to complete the Contract.

A.2 Plant Stock and Materials Documentation

Provide the following plant stock and Materials documentation:

- (1) Fifteen Working Days prior to beginning plant installation and establishment Work, provide the Engineer with a Department-preliminary *Certificate of Compliance for Plant Stock, Landscape Materials, and Equipment* (copy of form provided in the current edition of *ICAMMLP*)
- (2) At least five Working Days before plant stock delivery to the Project, provide the Engineer with the following:
 - (a) A copy of a valid nursery stock, dealer or grower certificate, registered with the Minnesota Department of Agriculture (MDA), a current nursery certificate or license from a state or provincial Department of Agriculture for each plant stock supplier, or both
 - (b) Documentation certifying that plant Material shipped from out-of-state nursery vendors subject to state and federal quarantines, is free of currently regulated pests, including Emerald Ash Borers, and Gypsy Moths. To determine if Minnesota vendors are subject to quarantines, call the MDA Supervisor of Nursery Inspection and Export Certification at (651) 201-6388

- (c) An updated Certificate of Compliance, signed by the Contractor's authorized representative
- (3) Upon delivery of plant stock and Materials to the Project, provide the Engineer with the following:
 - (a) Bills of lading or shipping documents for plant stock and landscape Materials delivered to the Project
 - (b) An updated and signed Certificate of Compliance, if necessary, to reflect deviations from the previous Certificate of Compliance documentation
- (4) As a condition for authorization of payments, provide the Engineer with vendor invoices or billing statements for plant stock and Materials used on the Project

The Engineer will consider Work performed with plant stock, Materials, or Equipment that was misrepresented in the documentation, as unauthorized Work.

A.3 Substitutions

The Engineer may allow substitutions in accordance with 1605, "Substitute Materials." Upon receipt of written documentation that plants shown on the Plans are not available in quantities to fulfill the Contract requirements, the Engineer, in consultation with the Project designer, may authorize specific substitute plants or may extend the Contract Time to ensure availability of the plants shown on the Plans. Provide substitutions equal to or better than the initially specified Materials.

2571.3 CONSTRUCTION REQUIREMENTS

A General

A.1 Landscape Specialist

Provide a Landscape Specialist, certified by the Department, to perform or supervise plant installation and establishment Work. Provide documentation of the Certified Landscape Specialist prior to beginning plant installation and establishment Work. Landscape Specialists may obtain certification by completing the 1-day Department Landscape Project Inspection and Administration Training Class and passing a test administered by the Department's Environmental Planning and Design Units. Full certification is valid for 3 years. Landscape Specialists may obtain provisional certification for 1 year by passing a test after completing the Department's online training class.

A.2 Notices by Contractor

Notify the Engineer at least 3 Calendar Days before planned deliveries of initial and replacement planting stock to the Project to allow for inspection scheduling. Notify the Engineer at least 24 hours before beginning or changing distinct operations. Include the following in the notice:

- (1) The Project number
- (2) Engineer's name
- (3) Notification date
- (4) Intended dates and times for the operations
- (5) The planned locations of Work

Provide notifications in writing, using confirmable e-mail or facsimile transmissions.

A.3 Unauthorized Work

The Engineer will consider Work performed as follows to be unauthorized Work:

- (1) Without required and acceptable documentation and notifications
- (2) Without supervision by a certified landscape specialist
- (3) Without conducting required and acceptable competency tests
- (4) In conflict with the working hours of the Contract

A.4 Required Equipment

Provide Equipment meeting the requirements of 1805, "Methods and Equipment," and with the following available on the Project at all times:

- (1) At least 1 portable compaction tester capable of measuring compaction in the soil to at least 18 inches deep
- (2) At least 1 soil recovery probe, or a soil moisture probe for assessment of soil moisture conditions
- (3) At least 1 tree caliper with measurement readings in inches

B Preconstruction Work

Preconstruction Work includes:

- (1) Attending a landscaping preconstruction meeting
- (2) Submitting landscaping preconstruction documentation
- (3) Mobilizing Equipment and supplies to the landscaping Project
- (4) Protecting existing vegetation, resources, and property in accordance with the Plans, Special Provisions, and 1712, "Protection and Restoration of Property," 2031, "Field Office and Laboratory," 2557, "Fencing," and 2572, "Protection and Restoration of Vegetation"

C Staking Planting Holes and Beds

Stake the exact locations and layouts for the landscape designer and Engineer's approval.

To remedy unanticipated, localized, or seasonal conditions that may hinder plant establishment, the Contractor may request the Engineer's approval to:

- (1) Relocate plantings
- (2) Make plant substitutions
- (3) Modify soil or drainage characteristics

D Preparing Planting Holes and Planting Beds

To prevent site compaction and damage, do not Work in planting holes and bed areas if the soil moisture is greater than field capacity.

D.1 Utilities

Before cultivating soil or excavating holes on the Project, meet the requirements of 1507, "Utility Property and Service."

The Contractor may request the Engineer's approval to relocate plantings to avoid unanticipated conflicts with utilities.

D.2 Weed Control and Soil Cultivation

Apply herbicide to actively growing vegetation beginning in spring or fall. Before cultivating individual planting holes and bed areas, kill turf and weed growth within the limits of planting areas that will receive mulch in accordance with the following:

- (1) Mow existing vegetation to at least 3 inches at least 7 Calendar Days before spraying herbicide. Remove the cuttings. Allow the vegetation to regrow to a height from 4 inches to 8 inches before applying the herbicide.
- (2) At least 3 Calendar Days before applying herbicide, submit to the Engineer, labels of the intended herbicides and a copy of a valid MN Pesticide Applicator License, including Category A and Category J.
- (3) Spray and kill turf and weeds, including the top growth and roots, only within designated areas using a non-selective, non-residual post emergent herbicide containing 41 percent glyphosate as the active ingredient. Ensure personnel, licensed by the MDA and experienced in the use of chemical pesticides perform the Work in accordance with the manufacturer's instructions and recommendations. Apply the herbicide to dry foliage on actively growing vegetation. Apply the herbicide in August or early September before the fall or spring Plant Installation Period (PIP) as required by the Contract. If an August or September application is not possible for the spring PIP, apply the herbicide in late April or early May. If precipitation occurs within 6 hours after applying herbicide, reapply herbicide as needed to achieve 100 percent kill.
- (4) Before beginning soil cultivation Work, schedule and perform a competency test to the satisfaction of the Engineer. The Engineer considers a satisfactory competency test one that demonstrates acceptable soil cultivation, incorporation of soil additives, compaction levels, and soil drainage in 1 planting bed area and 1 individual tree planting area.
- (5) Before placing soil additives as shown on the Plans, use a spading machine to deep cultivate the planting hole and bed areas by loosening the soil to at least 12 inches deep and a compaction level of no more than 200 psi to this depth, as measured from the finished grade elevation of the soil. The Engineer may approve other Equipment to address site constraints, if requested by the Contractor. For hydraulic spade-type, machine-moved tree-transplanting, the Engineer will not require planting hole cultivation, other than loosening the soil outside the soil-ball perimeter in accordance with the Standard Plans shown on the Plans.
- (6) Unless otherwise shown on the Plans, add 4 inches of Grade 2 compost, in accordance with 3890, "Compost" and other soil additives shown on the Plans or as requested by the Contractor and approved by the Engineer, over the cultivated planting hole and bed areas and use a spading machine to incorporate it to a depth of at least 12 inches, as measured from the finished grade elevation of the soil.
- (7) Use a compaction tester to ensure compaction in the planting hole and bed areas does not exceed 200 psi to a depth of at least 16 inches. If Contractor-operations result in zones of hardpan or excessively compacted soil, repeat deep cultivation or de-compact the subsoil in accordance with 2106.31, "Finishing Operations," specifically the requirements for turf establishment areas, at no additional cost to the Department.
- (8) Ensure drainage in the planting hole and bed areas. For suspected drainage problems, perform a percolation test by filling a 16 inches deep planting hole with water and measuring the time it takes the water to drain from the hole. The Engineer considers adequate drainage equal to or greater than a percolation rate of 1/2 inch per hour. If drainage does not meet these requirements, request approval from the Engineer to relocate or delete affected planting locations or proceed with Extra Work using one or a combination of the Standard Plans for poorly drained soils, as shown on the Plans.

- (9) Apply Temporary Erosion Control Measures in accordance with the NPDES Permit, SWPPP notes, and 2573, "Storm Water Management." The Contractor may use Type 6 wood chip mulch at a depth no more than 1 inch for temporary erosion control in prepared planting bed areas.

D.3 Wet Soils, Rock, and Debris

If the Contractor encounters excessively wet soils, bedrock, or excessive quantities of boulders and construction debris, the Contractor may request the Engineer's approval to relocate or delete plantings, or modify soil or drainage characteristics in accordance with the alternative options in the Standard Plans shown on the Plans.

E Delivery and Storage of Plants

Before installation, the Engineer will provide for inspection and acceptance of plant stock delivered to the Project in accordance with the current edition of the *ICAMMLP* and 3861, "Plant Stock."

Install plant stock on the day of delivery to the Project unless using temporary storage methods. Before installation, keep the roots of plants completely covered with a moisture-holding Material consisting of wood chips, straw, sawdust, moss, or soil. Keep the moisture-holding Material continuously moist and protect it from drying winds, direct sunlight, excessive heat, freezing, low humidity, inadequate ventilation, and animal or human harm. Remove tree trunk sleeves prior to inspection, acceptance, and planting. The Engineer will consider plants with damage that occurred or was discovered during temporary storage, unacceptable. Do not store plants from one planting season to the next.

E.1 Pruning — Top Growth and Roots

Immediately before planting, prune the roots of bare-root plants, except seedlings, and the top growth of deciduous plants. Cut-back broken or badly bruised roots and dry root tips to sound, healthy tissue. Prune to remove dead, rubbing, damaged, diseased, and suckering branches, and to improve plant symmetry, structure, and vigor. Prune coniferous trees and shrubs only to remove damaged growth or a competing leader.

Prune in accordance with the horticultural practices specified in the current edition of the *ICAMMLP* and the Standard Plans on the Plans.

Do not prune oak trees during the oak wilt season from April through July, to prevent the spread of oak wilt disease. Immediately treat accidental cuts or wounds to oaks with a wound dressing in accordance with the Standard Plans shown on the Plans. Keep wound-dressing Material on the project during the oak wilt season.

E.2 Buried Root Flares

The Engineer will consider container-grown and balled and burlapped plant stock unacceptable if provided with more than 4 inches of soil depth above the root flare. The Engineer may accept plants provided with no more than 4 inches of excess soil above the root flare if the excess soil can be removed without damaging the root system of the plants.

E.3 Excessive Roots

Reject containerized or balled and burlapped plants with roots extending at least 4 inches beyond the container or burlap.

F Installation of Plants

F.1 General

Before proceeding with plant installation Work, schedule and perform a competency test demonstrating acceptable plant installation methods to the Engineer's satisfaction and in accordance with the Plans and Standard Plans, for each plant Pay Item and root category on the

Project. The Engineer considers a satisfactory competency test to be one that demonstrates acceptable handling of plants, digging of holes and beds, installation of plants, initial watering, installation of protection Materials and mulching.

Before digging planting holes, rake temporary erosion control wood chip mulch off prepared planting areas to prevent wood chip contamination of the planting soil in the holes.

The Contractor may respread wood chip mulch formerly used as temporary erosion control around plants to a depth no greater than 1 inch following plant installation, if newly provided and acceptable Type 6 mulch is applied over the top to the depth shown on the Standard Plans in the Plans.

Dig planting holes to the configuration and minimum dimensions shown in the Standard Plans on the Plans. If the soil moisture is greater than field capacity, do not Work in planting holes and beds.

Ensure drainage in the planting hole and bed areas. For a suspected drainage problem, perform a percolation test by filling a 16 inches deep planting hole with water and measuring the time it takes the water to drain from the hole. The Engineer considers adequate drainage equal to or greater than a percolation rate of 1/2 inch per hour. If drainage does not meet these requirements, request approval from the Engineer to relocate or delete affected planting locations or proceed with Extra Work using one or a combination of the Standard Plans for poorly drained soils as shown on the Plans.

G Watering

Provide watering Equipment and forces on the Project capable of completely watering plants as often as necessary to maintain soil moisture in the root zones.

Within 2 hours of installation, saturate the backfill soil of each plant with water. After settling, provide additional backfill to fill in the voids.

H Mulch

Before placing mulch, fine grade and level the planting bed soils with hand tools. Place mulch Material in accordance with the Plans and Standard Plans no more than 7 Calendar Days after plant installation. Mulch contaminated with soil during installation or otherwise not complying with the requirements of 3882, "Mulch Material," is unacceptable. Remove unacceptable mulch from the Project.

I Protection of Installed Trees

Use protective Materials to ensure the healthy growth and survival of installed trees. Tree protection measures to address fall/winter environmental conditions must be removed the following spring.

I.1 Staking and Guying

Unless staking and guying is shown on the Plans, only stake and guy trees if necessary to maintain the trees in a plumb condition. The following circumstances may warrant staking and guying:

- (1) Excessive soil moisture
- (2) Light-textured soil
- (3) Steep slopes
- (4) Exposure to excessive wind
- (5) The likelihood of vandalism

Install staking and guying in accordance with the Standard Plans shown on the Plans.

Remove staking and guying within 1 year of initial installation.

I.2 Rodent Protection

Place rodent protection around deciduous, pine, and larch trees in accordance with the Standard Plans shown on the Plans.

I.3 Seedling Tree Shelters

Install seedling tree shelters in accordance with the Standard Plans shown on the Plans.

J Cleanup and Restoration Work

Perform the following cleanup and restoration Work on an ongoing basis and as the final step of the initial planting operations:

- (1) Remove excess Materials, rocks, and debris from the Project
- (2) Repair turf in disturbed areas with seed mixes as shown on the Plans or to match in-place turf
 - (a) Immediately before sowing seed or laying sod, prepare soil as specified in 2574.3, "Construction Requirements"
 - (b) Uniformly broadcast a Type 4 natural base fertilizer, as specified by 3881.2B.4, "Type 4 - Natural Based Fertilizer," that provides nitrogen at an application rate of 43 lb/acre
 - (c) Lay sod, or uniformly broadcast seed at 1.5 times the rate specified in Table 3876.2-1. Provide seed in accordance with the requirements of 3876, "Seed" and perform seeding in accordance with Table 2575.3-1
 - (d) Rake and firm seeded areas to ensure seed contact with the soil
 - (e) Broadcast or disc anchor Type 1 mulch in all seeded areas
- (3) Install erosion control measures to prevent erosion

K Plant Establishment Period

K.1 Establishment Period

A Plant Establishment Period (PEP) of at least 2 calendar years begins on the date that initial planting operations on the Project are completed and continues until final acceptance of the Project, unless otherwise shown on the Plans.

K.2 Establishment Work

Keep plants in a healthy growing condition in accordance with the current edition of the *ICAMMLP* throughout the establishment period and submit landscape Contractor scouting reports in accordance with item 1 of 2571.3K.2.a, "All Plants." Perform plant establishment Work throughout the growing seasons from April through October and as necessary during the dormant seasons from November through March. The Engineer may perform random inspections throughout the PEP to verify compliance. The Engineer will consider the Contractor non-compliant if the Contractor does not maintain plants throughout the PEP and does not submit scouting reports.

K.2.a All Plants

In plant establishment Work, perform the following:

- (1) Scout to assess the condition of the plants and the planting site and factors that may influence plant health, vigor, and establishment success. Scout these conditions at least every two weeks during the growing season and at least every month during the dormant season

SECTION 2571.2 K.2.A (2) NOT USED

- (2) Submit a written scouting report to the Engineer via e-mail by the 1st and 15th of each month during the growing season from April to October and by the 1st of each month during the dormant season from November to March. The Engineer will use the report-frequency and content to assess plant establishment compliance. The report may include scanned copies of the Plan sheets with the Contractor notes, copies of the report form found in the current edition of the *ICAMMLP*, or both. Include the following in the report:
- (a) The Project number
 - (b) Engineer's name
 - (c) Name of Contractor's responsible scout or representative
 - (d) Dates Work was performed
 - (e) Work locations
 - (f) Work completed
 - (g) Prevailing weather conditions
 - (h) Soil moisture assessments
 - (i) Insect, animal, vehicular, weather, or other damage
 - (j) Disease problems
 - (k) Treatment recommendations
 - (l) Assessment of overall plant conditions including weed competition and control
- (3) Maintain soil moisture in accordance with the watering guidelines of the Standard Plans shown on the Plans
- (4) Repair, adjust, or replace staking and guying, planting soil, rodent protection, seedling tree shelters, and other items in accordance with the Plans
- (5) Maintain healthy, vigorous plants; free of harmful insects, fungus, and disease without the use of systemic insecticides such as neonicotinoids
- (6) Remove dead, dying, and unsightly plants. Provide and install replacement plants in accordance with 2571.3K.2.b, "Replacement Requirements"
- (7) Maintain plants in a plumb condition at the planting depth shown on the Standard Plans in the Plans
- (8) Maintain planting areas in a weed-free condition as follows:
- (a) Remove weeds, top growth, and roots within the mulch limits by hand pulling. Pre-water mulched areas to ensure weed top growth and roots are entirely removed. Ensure weeding operations do not contaminate the mulch or Project with weed seed, weed-laden soil, or propagating weed parts. Remove State and County regulated noxious weeds to at least 5 feet beyond the mulch limits. Remove weed parts or weed-laden Material from the Project to avoid the spread of weed infestations
 - (b) Do not spray chemicals for weed control in mulched planting areas during the PEP. The Contractor may apply a non-selective, non-residual post-emergent herbicide containing 41 percent glyphosate, as the active ingredient with a surfactant on a spot treatment basis with a brush or wick applicator. The Contractor may also apply a broad-spectrum

dichlobenil based granular, pre-emergent herbicide in accordance with product labeling and manufacturer's recommendations

- (c) Do not weed whip or weed clip as weed control
 - (d) Mow turf bands around the mulch limits at least 5 feet beyond the limits and at least 4 inches high if the turf height exceeds 9 inches adjacent to mulched planting areas
 - (e) Mow turf areas installed as part of the Project when the growth exceeds 18 inches high. Mow turf from 6 inches to 12 inches high. Control State and County-listed noxious weeds
- (9) Prune to remove dead, rubbing, damaged, or diseased branches, unwanted suckers, and to improve plant form and structure
 - (10) Prevent or repair rutting and other damage that may lead to soil erosion and weed infestation
 - (11) Perform plant establishment operations consistent with plant care and horticultural practices detailed in the current edition of the *ICAMMLP*
 - (12) Remove excess Material, obsolete temporary erosion control devices, rocks, and debris from the Project

K.2.b Replacement Requirements

Within the first year of the 2-year PEP, determine which plants need replacing. Replace dead, defective, or missing plants and Materials in accordance with initial installation requirements, including plants lost due to accidents, vandalism, theft, rodent damage, damage caused by the Contractor, or if ordered by the Engineer, at no additional cost to the Department. Conduct plant replacement operations during the month of May or September, based on the start of the PEP. At least 7 Calendar Days before plant replacement, submit a summary report of proposed plant replacements to the Engineer. Include by attachment, copies of Plan sheets with the proposed replacement quantities and locations identified and a Department Certificate of Compliance for Plant Stock, Landscape Material, and Equipment, in the report. Using brightly colored paint, mark on site plants requiring replacement.

Provide replacement plants and Materials that are equal to or better than the initial Material required by the Contract.

If less than a full year remains in the PEP, do not replace plants unless the PEP is extended by a Change Order to provide at least one full year of establishment care.

L Acceptance of Work

L.1 Acceptance of Preconstruction Work

The Engineer will accept the preconstruction Work after the Contractor secures commitments for required Materials, submits a Department Certificate of Compliance for Plant Stock, Landscape Materials, and Equipment, participates in a preconstruction meeting, obtains the Engineer's approval for the Progress schedule, moves Equipment and supplies to the Project, and provides protection for existing plants.

L.2 Acceptance of Preparation of Planting Holes and Beds

For the Engineer's acceptance of preparation of planting holes and beds, complete a competency test, other specified staking, initial weed control, soil cultivation including incorporation of additives, and temporary erosion control Work.

L.3 Acceptance of Initial Planting Operation

The Engineer will accept initial planting operations based on the following:

- (1) Plant stock acceptance
- (2) Completion of a competency test
- (3) Installation of individual plants
- (4) All Material and Work items shown in the initial planting operations chapter of the current edition of the *ICAMMLP*, including but not limited to watering, tree protection Materials, mulching, proper drainage, pruning, staking and guying, fertilizing, erosion control, seeding, and clean up, in accordance with 1516.2, "Project Acceptance."

L.4 Final Acceptance

As a condition for terminating the PEP and conducting the final inspection, the Engineer may require the Contractor to bring the plant establishment Work into compliance.

On or about the date of termination of the PEP, the Engineer will perform a final inspection of the Project.

Upon final acceptance, the Engineer will not require further Contractor-care of plantings.

The Engineer will make final acceptance at the completion of the two-year PEP and based on a final inspection of the completed Project.

2571.4 METHOD OF MEASUREMENT

The Engineer will measure plants separately by the number of acceptable plants for each Contract Item in accordance with 2571.5G, "Payment Schedule."

2571.5 BASIS OF PAYMENT

The Department will make payment for plant installation and establishment at a percentage of the Contract Unit Price per item unit of measure for all costs relating to furnishing, installing, and establishing, the required plants and associated Materials as specified and shown on the Plans.

The Department may make full payment, reduced payment or no payment of no more than the maximum eligible partial payment percentage at any payment phase (initial, interim, final) based on the performance of the Contractor and in accordance with 1906, "Partial Payment," and 1908, "Final Estimate and Payment – Conditions and Process."

A Initial Payment

The Department will make payment for plant installation and establishment at a percentage of the Contract Unit Price for each plant for completion of the following Work:

A.1 Preconstruction Work

The Department will pay no more than 10 percent of the Contract Unit Price for each plant with the completion and acceptance of preconstruction Work as defined in the Preconstruction Work Checklist in the current edition of the *ICAMMLP*.

A.2 Preparation of Planting Holes and Beds

The Department will pay no more than 15 percent of the Contract Unit Price for each plant with the completion and acceptance of preparation of planting holes and beds Work as defined in the Preparation of Planting Holes and Beds Checklist in the current edition of the *ICAMMLP*.

SECTION 2571.4 THROUGH 2571.5 NOT USED

SECTION 2571.4 THROUGH 2571.5 NOT USED

2571

A.3 Initial Planting Operations

The Department will pay no more than 45 percent of the Contract Unit Price for each plant with the completion and acceptance of initial planting operations Work as defined in the Initial Planting Operations Checklist in the current edition of the *ICAMMLP*.

B Interim Payment

At the end of the first calendar year of the PEP, and after completion and acceptance of the Contractor's Work and continuous compliance with the plant establishment requirements as defined by the Plant Establishment-Year One Checklist in the current edition of the *ICAMMLP*, the Engineer may authorize no more than 15 percent of the Contract Unit Price for each plant.

C Final Payment

The Department will make final payment after final inspection and acceptance of the completed Project at the end of the PEP. The Engineer may authorize no more than 15 percent of the Contract Unit Price for each plant as defined by the Plant Establishment Year 2 Checklist in the current edition at the time of letting of the *ICAMMLP*. The total final payment includes the Plant Establishment Year 2 payment, assessments and reduced payments, if any, and Incentive payment, if eligible.

The Department will not pay for replacement plants, unless authorized by the Engineer.

The Department may continue to withhold any percentage of initial and interim payments from the final payment.

The Department will require a prompt refund of any overpayment, if the final voucher shows that the total of initial and interim payments made exceeds the total amount due the Contractor.

D Incentive Payment

When 90 percent or more of all plants installed within the initial plant installation period (PIP) and related Contract operations have been continuously acceptable throughout the Contract period, the Department will make an Incentive payment of 10 percent of the total final Contract Unit Price for plant installation and establishment.

The Department considers replacement plants, replaced during the initial PIP, to be initially installed plants. Replacement plants made during the PEP are not eligible for Incentives.

E Withholdings

E.1 Plant Stock and Materials Documentation

If the Contractor does not provide the documentation required by 2571.2A.2, "Plant Stock and Materials Documentation," the Department may withhold a percentage of the PIP payment as described in checklist B2, in accordance with the current edition of *ICAMMLP*.

E.2 Plant Establishment Period

The Department may withhold a percentage of the PEP payment as described on checklist B9-B10, in accordance with the current edition of *ICAMMLP*.

F Monetary Adjustments

The Department must apply Incentives and Disincentives and may apply monetary deductions for Plant Installation and Establishment. The amounts of these adjustments are deemed reasonable.

The Department may make full payment or apply a monetary deduction of no more than the maximum eligible partial payment percentage at any payment phase (initial, interim, final) based on the performance of the Contractor (see Payment Checklist in the current edition of the *ICAMMLP*).

The Engineer will determine which plants to accept for payment at the Contract Unit Price or at a monetary deduction.

G Schedule

The Department will pay for plant installation and establishment on the basis of the following schedule:

Item No.	Item	Unit
2571.502	Coniferous Tree Size & Root Category	each
2571. 502	Deciduous Tree Size & Root Category	each
2571. 502	Ornamental Tree Size & root Category	each
2571. 502	Transplant Tree (Spade Size*)	each
2571. 502	Coniferous Shrub Size & Root Category	each
2571. 502	Deciduous Shrub Size & Root Category	each
2571. 502	Transplant Shrub	each
2571. 502	Transplant Vine	each
2571. 502	Vine Age or Size & Root Category	each
2571. 502	Perennial Age or Size & Root Category	each
2571. 502	Transplant Perennial	each

NOTE: State Root Category: Seedling, Bare Root, Machine Moved, Container Grown, Balled and Burlapped

* Spade size: 42 inch, 60 inch, 78 inch, 85 inch, 90 inch.

2572 PROTECTION AND RESTORATION OF VEGETATION

2572.1 DESCRIPTION

This Work consists of protecting and preserving vegetation from damage and restoring vegetation damaged by the Contractor’s operations.

2572.2 MATERIALS

A Plant Materials 2571 and 2575

B Temporary Fence

Provide temporary fence meeting the following characteristics and requirements:

- (1) At least 4 feet
- (2) Conspicuous in color (see Standard Detail Sheet for Protection and Restoration of Vegetation)
- (3) Commercially available snow fence or other fencing Material approved by the Engineer

C Water

Provide municipal potable water or harvested ground water for irrigation.

D Rooting Topsoil Borrow 3877

E Tree Growth Retardant (TGR)

Provide the TGR paclobutrazol or an equal approved by the Engineer.

2572.3 CONSTRUCTION REQUIREMENTS**A Protecting and Preserving**

Protect and preserve the following:

- (1) Specimen Trees
- (2) Threatened and endangered plants listed on the Federal and State threatened and endangered species list
- (3) Vegetation as required by the Contract
- (4) Trees, Brush, and natural scenic elements within the Right-of-way and outside the limits of clearing and grubbing in accordance with 2101.3, "Clearing and Grubbing, Construction Requirements"
- (5) Other vegetation as directed by the Engineer

Do not place temporary Structures, store Material, or conduct unnecessary construction activities within 25.25 feet outside of the dripline of trees designated for preservation, unless otherwise approved by the Engineer.

Do not place temporary Structures or store Material, including common borrow and topsoil, outside of the construction limits in areas designated for preservation, as required by the Contract or as approved by the Engineer.

Do not place or leave waste Material on the Project, including bituminous and concrete waste that would interfere with performing the requirements of 2106.3D, "Preparation of Embankment Foundation," or 2575, "Establishing Vegetation and Controlling Erosion." The Department defines concrete waste as excess Material not used on the Project, including Material created from grinding rumble strips. Dispose of excess Material in accordance with 2104.3D, "Disposal of Materials and Debris."

A.1 Temporary Fence

Place temporary fences to protect vegetation before starting construction. Place temporary fence at the construction limits and at other locations adjacent to vegetation designated for preservation as required by the Contract or as approved by the Engineer. The Department will provide tree protection signs. Place tree protection signs in accordance with any of the following:

- (1) Along the temporary fence at 50 foot intervals
- (2) At least 2 signs per fence
- (3) As directed by the Engineer

Do not remove the fence until all Work is completed or until approved by the Engineer.

Ensure the fence prevents traffic movement and the placement of temporary facilities, Equipment, stockpiles, and supplies from harming the vegetation.

A.2 Clean Root Cutting

Cleanly cut tree roots at the construction limits as required by the Contract or as directed by the Engineer.

Immediately and cleanly cut damaged and exposed roots. Cut back damaged roots of trees designated for protection to sound healthy tissue and immediately place topsoil over the exposed roots. Immediately cover root ends exposed by excavation activities with 6 inches of topsoil as measured outward from the cut root ends. Immediately (within 5 minutes) treat cut oak roots with a wound dressing Material consisting of latex paint or shellac. Limit cutting to a minimum depth necessary for construction. Use a vibratory plow, or other approved root cutter

in accordance with the Standard Detail Sheet for Protection and Restoration of Vegetation, before excavation.

A.3 Watering

Water root-damaged trees during the growing season that root damage occurs, and water Specified Trees if required by the Contract or directed by the Engineer. Maintain adequate but not excessive soil moisture by saturating the soil within the undisturbed portion of the dripline of impacted or identified trees to a depth of 20 inches. Use a soil recovery probe to check the soil moisture to a depth of 20 inches, and adjust the intervals and frequency of watering in accordance with prevailing moisture and weather conditions.

A.4 Rooting Topsoil Borrow

Place rooting topsoil borrow instead of common topsoil borrow within the dripline of Specimen Trees as required by the Contract or as directed by the Engineer.

Place the topsoil to avoid over-compaction as approved by the Engineer. Establish turf consistent with the adjacent areas as approved by the Engineer.

A.5 Utility Construction

Bore under roots of trees designated for preservation for utility installations within the tree protection zone in accordance with the following:

**Table 2572.3-1
Tree Protection Zone**

Tree diameter at 4.5 feet above ground, inch	Minimum distance from face of tree trunk, feet	Minimum depth of tunnel, feet
<2	2	3
2-4	4	3
>4-9	6	3
>9-14	10	3
>14-19	12	3.25
>19	15	4

Do not perform open trenching within the tree protection zone.

Bore under areas of native prairie and protected plant species as required by the Contract or as directed by the Engineer.

A.6 Pruning

Provide an arborist certified by the International Society of Arboriculture to prune trees as required by the Contract or as directed by the Engineer in accordance with 2571.3E.1, "Pruning – Top Growth and Roots." Ensure the arborist removes dead, broken, rubbing branches, and limbs that may interfere with the existing and proposed Structures.

A.7 Destroyed or Disfigured Vegetation

Restore vegetation designated on the Plans for preservation that is damaged or disfigured by the Contractor's operations at no additional cost to the Department. Restore the damaged vegetation to a condition equal to what existed before the damage. The Engineer may assess damages against the Contractor for damage to vegetation not restored to the previous condition. The Engineer will assess the value of damages to trees and landscaping at not less than the appraisal damages as specified in the Council of Tree and Landscape Appraisers *Guide for Plant Appraisal*. The Engineer will determine and assess damages of other vegetation.

A.8 Oak Trees

Avoid wounding of oak trees during April, May, June, and July to prevent the spread of oak wilt. If the Engineer determines that Work must take place near oak trees during those months, immediately (within 5 minutes) treat resulting wounds with a wound dressing Material consisting of latex paint or shellac. Blend paint colors with the bark color. Maintain a supply of approved wound dressing on the Project at all times during this period.

A.9 Tree Growth Retardant (TGR)

Provide an arborist certified by the International Society of Arboriculture to treat trees with the TGR as required by the Contract or as directed by the Engineer. Ensure the arborist applies the TGR paclobutrazol as a basal drench or soil injection and in accordance with the label directions. Provide the Engineer with the product label and Material Safety Data Sheet for the product used.

A.10 Other Vegetation Protection Measures

Provide other vegetation protection measures including root system bridging, compaction reduction, aeration, irrigation systems, J-barriers for Specimen Tree protection, and retaining walls as required by the Contract or as directed by the Engineer.

B Quarantined Wood..... 2101.3D.4

C Plant Installation 2571

D Disposal of Material and Debris..... 2104.3D

2572.4 METHOD OF MEASUREMENT

A Temporary Fence

The Engineer will measure temporary fence placed, maintained, and removed by length along the bottom of the fence between end posts.

B Clean Root Cutting

The Engineer will measure clean root cutting by length along the plow line. The Engineer will determine the beginning and ending points for clean root cutting as the intersection of the construction limit and the dripline of the tree or Brush or in accordance with lines shown on the Plans.

C Water

The Engineer will measure water by volume used to protect and restore vegetation. The Engineer will not measure water otherwise used in performing the Work, such as for maintenance of sod.

D Rooting Topsoil Borrow

The Engineer will measure rooting topsoil borrow by loose volume as required by the Contract.

E Pruning

The Engineer will measure pruning by the hours of actual pruning Work.

F Tree Growth Retardant (TGR)

The Engineer will measure TGR by volume of Material applied for the size of the tree treated. The Engineer will determine the volume of TGR required by the diameter at breast height (DBH) of each tree treated. DBH is defined as 4.5 feet above ground level. The Engineer will use a diameter tape measure to measure DBH.

SECTION 2572.4 NOT USED