

City of Falcon Heights
Regular Meeting of the City Council
City Hall
2077 W. Larpenteur Avenue

March 25, 1998
A G E N D A

- A. CALL TO ORDER: 7 p.m.
- B. ROLL CALL: GEHRZ ___ GIBSON TALBOT ___ HUSTAD ___
 JACOBS ___ KUETTEL ___ HOYT ___ ASLESON ___
 ATTORNEY ___ ENGINEER ___
- C. COMMUNITY FORUM
- D. APPROVAL OF MINUTES: March 11, 1998
- E. PUBLIC HEARING:
 - 1. Public hearing on proposed assessments for the 1998 Larpenteur Avenue project
- F. CONSENT AGENDA:
 - 1. Disbursements
 - a. General disbursements through 3/19/98, \$51,361.18
 - b. Payroll, 3/1/98 to 3/15/98, \$9,305.56
 - 2. Licenses
 - 3. Proposed text changes in the city's cooperative service policy to conform to legal practice
- G. POLICY AGENDA:
 - 1. Consideration of Resolution 98-07 adopting the 1998 Larpenteur Avenue assessment roll
 - 2. Update on the city costs for phase II of the Larpenteur Avenue street reconstruction being done by Ramsey County
 - 3. Consideration of an assessment rate for streetlights on Hoyt Avenue west of Cleveland
 - 4. Resolution receiving feasibility report and calling for hearing on the 1998 improvement of Hoyt Avenue (west of Cleveland Avenue)
 - 5. Update on the petition for the Capital Region Watershed District from the Board of Water and Soil Resources (BWSR)
 - 6. Consideration of 1998 volunteer recognition activities
 - 7. Consideration of request from Dispute Resolution Center to provide funding for a cooperative service venture
 - 8. Change in Solid Waste Commission meeting plans
- H. INFORMATION AND ANNOUNCEMENTS:
- I. ADJOURN

City of Falcon Heights
Regular Meeting of the City Council
City Hall
2077 W. Larpenteur Avenue

March 25, 1998
A G E N D A

- A. CALL TO ORDER: 7 p.m.
- B. ROLL CALL: GEHRZ ___ GIBSON TALBOT ___ HUSTAD ___
 JACOBS ___ KUETTEL ___ HOYT ___ ASLESON ___
 ATTORNEY ___ ENGINEER ___
- C. COMMUNITY FORUM
- D. APPROVAL OF MINUTES: March 11, 1998 Tab #1)
- E. PUBLIC HEARING: (Tab #2)
 - 1. Public hearing on proposed assessments for the 1998 Larpenteur Avenue project
- F. CONSENT AGENDA:
 - 1. Disbursements (Tab #3)
 - a. General disbursements through 3/19/98, \$51,361.18
 - b. Payroll, 3/1/98 to 3/15/98, \$9,305.56
 - 2. Licenses (Tab #4)
 - 3. Proposed text changes in the city's cooperative service policy to conform to legal practice (Tab #5)
- G. POLICY AGENDA:
 - 1. Consideration of Resolution 98-07 adopting the 1998 Larpenteur Avenue assessment roll (Tab #6)
 - 2. Update on the city costs for phase II of the Larpenteur Avenue street reconstruction being done by Ramsey County (Tab #7)
 - 3. Consideration of an assessment rate for streetlights on Hoyt Avenue west of Cleveland (Tab #8)
 - 4. Resolution receiving feasibility report and calling for hearing on the 1998 improvement of Hoyt Avenue (west of Cleveland Avenue) (Tab #9)
 - 5. Update on the petition for the Capital Region Watershed District from the Board of Water and Soil Resources (BWSR) (Tab #10)
 - 6. Consideration of 1998 volunteer recognition activities (Tab #11)
 - 7. Consideration of request from Dispute Resolution Center to provide funding for a cooperative service venture (Tab #12)
 - 8. Change in Solid Waste Commission meeting plans (Tab #13)
- H. INFORMATION AND ANNOUNCEMENTS:
- I. ADJOURN

DRAFT

**CITY OF FALCON HEIGHTS
REGULAR CITY COUNCIL MEETING
MINUTES OF MARCH 11, 1998**

Mayor Gehrz convened the meeting at 7:05 p.m.

PRESENT

Gehrz, Gibson Talbot, Hustad, Kuettel, and Jacobs. Also present was Hoyt and Asleson.

COMMUNITY FORUM

There was no one wishing to take advantage of the community forum.

MINUTES OF FEBRUARY 25, 1998

Minutes were approved by unanimous consent.

CONSENT AGENDA APPROVED

Councilmember Gibson Talbot moved to approve the following consent agenda. The motion passed unanimously.

1. Disbursements
2. Licenses
3. Authorization to hire Astech Corporation for 1998 spring and fall streetsweeping
4. Authorization to purchase a 1998 one ton Chevrolet four wheel drive truck
5. Authorization to adjust the mileage reimbursement rate to \$.325/mile
6. Approval of cooperative service expenditure request to Retired Senior Volunteer Program (RSVP)

POLICY AGENDA

CONSIDERATION OF POLICE COSTS FOR 1999 AND 2000

Administrator Hoyt explained that the council is being asked to approve 1999 and 2000 costs for contracting with the City of St. Anthony for police services. The contract between the two cities requires that contract costs be negotiated every two years. The proposed cost increases are 5% for 1999 (contract cost \$381,507) and 4% for 2000 (contract cost \$396,767).

Police Chief Engstrom told the council that his department enjoys serving the City of Falcon Heights. He explained some of the items behind the proposed cost increases, including increases in the costs of personnel, health insurance, automotive supplies, and mandated training. He also discussed the community policing approach with a dedicated officer for 24 hour a day coverage in Falcon Heights.

Following discussion, Councilmember Kuettel made a motion to adopt the proposed police cost increases for 1999 and 2000. The motion passed unanimously.

**DISCUSSION AND RECOMMENDATION ON THE GOVERNANCE OF THE CENTRAL
RAMSEY WATERSHED**

Administrator Hoyt reported that the council had learned about the proposed petition for the Central Ramsey watershed to become a Watershed District at their previous meeting. The purpose of having it on the agenda again is to determine if the council wishes to make comments regarding the issue at the Board of Water and Soil Resources (BWSR) public hearing on April 6, 1998. Hoyt then reviewed the possible governance models for the watershed: remaining a Water Management Organization, being a stand alone watershed district (possibly combined with Southwest Ramsey) or combining Central Ramsey with the existing Ramsey-Washington Watershed District.

Dr. William Downing, 1834 Simpson Street, urged the city council to take a position at the BWSR hearing rather than leaving the decision to other cities or to BWSR. Dr. Downing stated that he favors a stand-alone watershed district that combines the Central Ramsey and Southwest Ramsey watersheds. He does not favor combination with Ramsey-Washington since that watershed has a lot of new development rather than being fully developed, and he fears that Central Ramsey and Southwest Ramsey would end up subsidizing the more expensive projects in the Ramsey-Washington area.

Following discussion, a motion was made by Councilmember Jacobs to submit the following comments to BWSR: The City of Falcon Heights supports combining the Central Ramsey and Southwest Ramsey watersheds into a single, independent watershed district for three reasons: 1) to provide effective management of water quality in these watersheds, 2) to focus the new district's mission on improving water quality in a fully developed, urban environment, 3) to maximize citizen representation and access to the Board of Governors of the new watershed district by guaranteeing that all five managers would be appointed from and represent the interests of the Central Ramsey and Southwest Ramsey watershed districts, and 4) to assure property owners that property taxes levied and collected by the new watershed district would directly and only benefit properties in the Central Ramsey and Southwest Ramsey watersheds. The motion passed unanimously.

DISCUSSION OF PLANNING FOR THE CITY'S 50TH BIRTHDAY PARTY

Mayor Gehrz reported that the first meeting of the planning committee for the city's 50th birthday party would be held on March 31, 1998. The council discussed the amount of direction to give to the committee and decided to allow the committee, at least initially, to brainstorm ideas on their own.

ADJOURNMENT

The meeting adjourned at 8:32 p.m.

Susan L. Gehrz, Mayor

Carla Asleson
Recording Secretary

PUBLIC HEARING

Date: 3/25/98

ITEM DESCRIPTION: Public hearing on proposed assessments for the 1998 Larpenteur Avenue project

SUBMITTED BY: Terry Maurer, City Engineer

REVIEWED BY: Susan Hoyt, City Administrator
Carla Asleson, Administrative Assistant/Planner

EXPLANATION/SUMMARY:

Summary and Action Requested. Hold required public hearing regarding assessment amounts for the Larpenteur Avenue project.

Goal 2: To maintain and promote the assets of the city's unique neighborhoods including commercial, residential, and open space uses for present and future generations.

Strategy 4: Maintaining the city's infrastructure.

Action Item: Implement scheduled street improvement projects

Background. Notices regarding this public hearing were published in the Focus newspaper and mailed to each affected property owner two weeks prior to the hearing date, as required by law. Individual property owners' notices detailed the amount of assessment that is proposed to be due and the means by which a property owner may pay it. This notice also outlined the means by which a property owner may protest his assessment amount: either by submitting a written objection to the clerk before the hearing or to the mayor at the time of the hearing. To date, no written objections to assessment amounts have been received.

The assessments were calculated at \$26.50 per lineal front foot for residential property, \$35.00 per front foot for commercial property and \$53.00 for tax exempt property (city hall parcels). The University of Minnesota and State Fair will be paying for their portion of the construction costs outside of the special assessment process.

ATTACHMENT: Sample hearing notice

ACTION REQUESTED:

- Hear report from City Engineer on the improvement and proposed assessments
- Open public hearing (no earlier than 7:00 p.m.) and receive testimony
- Close public hearing

City of Falcon Heights
2077 W. Larpenteur Avenue
Falcon Heights, MN 55113

Property Identification Number: 16-29-23-33-0003
Property Address: 2061 W. Larpenteur Avenue

CITY OF FALCON HEIGHTS ASSESSMENT INFORMATION ENCLOSED

The 1998 Larpenteur Avenue improvement project is scheduled to begin in April. Enclosed you will find information on the public hearing and assessment amount owed for this improvement. The materials enclosed are in a format required by law. While these documents are important and should be read carefully, they can be summarized as follows:

THE AMOUNT OF ASSESSMENT THAT YOU OWE FOR THIS PROPERTY:

\$6,457.50

PUBLIC HEARING TO BE HELD ON THIS ASSESSMENT:

March 25, 1998, on or after 7:00 p.m., Falcon Heights City Hall

IF YOU WISH TO PROTEST YOUR ASSESSMENT AMOUNT, YOU MUST EITHER:

- Submit a written statement of protest to the City Clerk prior to the hearing (this may be done by mail); or
- Attend the public hearing on March 25th and submit a written protest at that time.

Written protests should include the property owner's name, address, and reason for protesting the amount of assessment.

YOU HAVE TWO OPTIONS WITH RESPECT TO THIS PAYING THIS ASSESSMENT:

1. If you pay the entire assessment amount to the city before April 24, 1998, you will not owe any interest. Payments may be mailed to: City of Falcon Heights, 2077 W. Larpenteur Avenue, Falcon Heights, MN 55113, made in person at City Hall between the hours of 8:00 a.m. and 4:30 p.m., or left in the after hours drop box located at city hall.
2. If your full assessment amount is not received by the city by April 24, it will be placed with applicable interest on your property tax statement. The interest rate on the assessment is seven percent (7%) per year, with payments made over the next ten (10) years.

You may pay off the entire amount owed, with applicable interest, at any time after April 24, 1998 through the Ramsey County Department of Records and Revenue (266-2020).

THIS IS THE ONLY NOTICE YOU WILL RECEIVE FOR THIS ASSESSMENT. YOU WILL NOT BE BILLED.

STATE OF MINNESOTA
CITY OF FALCON HEIGHTS

City of Falcon Heights
2077 W. Larpenteur Avenue
Falcon Heights, MN 55113

Property Identification Number: 16-29-23-33-0003
Property Address: 2061 W. Larpenteur Avenue

TO WHOM IT MAY CONCERN:

Notice is hereby given that the Falcon Heights City Council will meet at 7:00 p.m on March 25, 1998 at Falcon Heights City Hall to pass upon the proposed assessment for improvement of Larpenteur Avenue. It is proposed that the cost of the Improvement be assessed against the following property parcels on Larpenteur Avenue:

16-29-23-33-0002 through 16-29-23-33-0003
16-29-23-34-0018 through 16-29-23-34-0022
16-29-23-34-0026 through 16-29-23-34-0027
16-29-23-34-0073 through 16-29-23-34-0074
16-29-23-34-0086 through 16-29-23-34-0090
16-29-23-44-0023
21-29-23-11-0001 through 21-29-23-11-0002
21-29-23-11-0024
21-29-23-12-0002 through 21-29-23-12-0008

The amount to be specially assessed against your particular lot, piece, or parcel of land is \$6,457.50. You may at any time prior to certification of the assessment to the County Auditor, pay the entire assessment on such property, with interest accrued to the date of payment. No interest shall be charged if the entire assessment is paid within 30 days from this adoption of the assessment. You may at any time thereafter pay to the Ramsey County Auditor the entire amount of the assessment remaining unpaid, with interest accrued to December 31st of the next succeeding year. If you decide not to prepay the assessment before the date given above, the rate of interest that will apply is seven percent per year.

The proposed assessment roll is on file for public inspection at the City Clerk's office. The total amount of the proposed assessment is \$89,605.45. Written or oral objections will be considered at the meeting. No appeal may be taken as to the amount of an assessment unless a signed, written objection is filed with the Clerk prior to the hearing or presented to the presiding officer at the hearing.

An owner may appeal an assessment to District Court pursuant to Minnesota Statutes Section 429.081 by serving notice of the appeal upon the Mayor or Clerk of the City within 30 days after the adoption of the assessment and filing such notice with the District Court within ten days after service upon the Mayor or Clerk.

Under Minnesota Statutes, Sections 435.193 to 435.195 the Council may, in its discretion, defer the payment of this special assessment for any homestead property owned by a person 65 years of age or older for whom it would be a hardship to make the payments. When deferment of the special assessment has been granted and is terminated for any reason provided in that law, all amounts accumulated plus applicable interest become due. Any assessed property owner meeting the requirements of this law and the ordinance (resolution) adopted under it may, within 30 days of the confirmation of the assessment, apply to the City Clerk for the prescribed form for such deferral of payment of this special assessment on this property.

Hearing impaired persons or other persons with disabilities who require auxiliary aids or special accommodations at the hearing should contact Carla Asleson at 644-5050 by March 18, 1998.

THIS IS THE ONLY NOTICE YOU WILL RECEIVE FOR THIS ASSESSMENT. YOU WILL NOT BE BILLED.

/s/ Carla Asleson
City Clerk, Falcon Heights

LARPENTEUR IMPROVEMENT ASSESSMENTS
AMORTIZATION SCHEDULE

ASSESSMENT HEARING DATE MARCH 25, 1998

REGULAR INTEREST RATE OF 7.00%

ESTIMATED ASSESSMENT: \$6,457.50

1ST YEAR INTEREST CALCULATION:

<u>Number of days left in year</u>	X	<u>Interest rate</u>		
Number of days in year		1		
281	X	0.07	=	0.053890
365		1		

0.05389	Interest for days left in 1998	
0.07000	Regular interest rate	
0.12389	First year interest rate (3/26/98 through 12/31/99))	

Taxes Paid in			
1999	Principal pymt:	\$645.75	
	Interest pymt:	\$800.02	
	Total:	\$1,445.77	
2000	Principal pymt:	\$645.75	
	Interest pymt:	\$406.82	
	Total:	\$1,052.57	
2001	Principal pymt:	\$645.75	
	Interest pymt:	\$381.52	
	Total:	\$1,027.27	
2002	Principal pymt:	\$645.75	
	Interest pymt:	\$316.42	
	Total:	\$962.17	
2003	Principal pymt:	\$645.75	
	Interest pymt:	\$271.22	
	Total:	\$916.97	
2004	Principal pymt:	\$645.75	
	Interest pymt:	\$226.01	
	Total:	\$871.76	
2005	Principal pymt:	\$645.75	
	Interest pymt:	\$180.81	
	Total:	\$826.56	
2006	Principal pymt:	\$645.75	
	Interest pymt:	\$135.61	
	Total:	\$781.36	
2007	Principal pymt:	\$645.75	
	Interest pymt:	\$90.41	
	Total:	\$736.16	
2008	Principal pymt:	\$645.75	
	Interest pymt:	\$45.20	
	Total:	\$690.95	

Total Principal Payments	\$6,457.50
Total Interest Payments	\$2,834.13
TOTAL PAYMENTS FOR 10 YEAR PLAN:	\$9,291.63

Note: This sheet is for reference only. Some numbers may differ on your tax statement due to rounding.

CONSENT
Meeting Date: 3/25/98
Item: 1

ITEM DESCRIPTION: Disbursements

SUBMITTED BY: Roland Olson, City Accountant

EXPLANATION/SUMMARY:

- a. General disbursements through 3/19/98, \$51,361.18
- b. Payroll, 3/1/98 to 3/15/98, \$9,305.56

ACTION REQUESTED: Approval

a.

APPROVAL OF BILLS
PERIOD ENDING: 3-19-98

CHECK#	VENDOR NAME	DESCRIPTION	DEPT.	AMOUNT
	NORTHWEST YOUTH & FAMILY	4/98 TEEN COURT SVCS	-----	4,682.10
	*** TOTAL	FOR DEPT 00		4,682.10
35959	BANK CARD CENTER	WASH DC LEAGUE OF CITIES	LEGISLAT	347.00
	CASH	PICTURES FOR MAYOR	LEGISLAT	10.85
	FOCUS NEWS	98 LARP ASSESSMT HEARING	LEGISLAT	110.50
	MIDDLE MISSISSIPPI RIVER	SHARE 98 OPER BUD MMRWMO	LEGISLAT	19.35
	NORTHWEST YOUTH & FAMILY	KUETTEL YOUTH AWARDS CEL	LEGISLAT	15.00
	RETIRED SENIOR VOLTR PRGM	1998 EXPENDITURES SVC	LEGISLAT	100.00
	*** TOTAL	FOR DEPT 11		602.70
	CARLA ASLESON	MISC SUPPLIES	ADMINIST	7.77
	CARLA ASLESON	MILEAGE REIMBURSEMENT	ADMINIST	11.34
	AMERICAN OFFICE PRODUCTS	POST IT NOTES/PENS/CLIPS	ADMINIST	66.69
	AMERICAN OFFICE PRODUCTS	SCISSORS/LEGAL PADS/ENVL	ADMINIST	132.84
36009	BANK CARD CENTER-FBS	PRINTER CABLES	ADMINIST	29.95
36009	BANK CARD CENTER-FBS	POSTAGE	ADMINIST	870.00
35959	BANK CARD CENTER	POSTAGE	ADMINIST	649.60
	CASH	POSTAGE	ADMINIST	10.08
	CASH	FRAME FOR POSTER	ADMINIST	10.64
	ICMA RETIREMENT TRUST 457	3/98 CARLA	ADMINIST	200.00
	LEAGUE OF MN CITIES	SUBSCRIPTION-CITIES BULL	ADMINIST	40.00
35958	MN DEPARTMENT OF REVENUE	3/15 ST WITHHOLDINGS	ADMINIST	619.41
	NORTHWEST YOUTH & FAMILY	CITY ADMIN YOUTH AWARDSB	ADMINIST	15.00
35956	PERA	3/15 PERA WITHHOLDINGS	ADMINIST	1,326.19
36011	TAFF, SUSAN HOYT	WASH DC LEAGUE CITIES	ADMINIST	31.00
	BRODERICK, BERNARD	MILEAGE REIMBURSEMENT	ADMINIST	4.81
	*** TOTAL	FOR DEPT 12		4,025.32
	ROLAND OLSON	MILEAGE REIMBURSEMENT	FINANCE	18.20
	RAMSEY COUNTY	LIST OF MAJOR TAXPAYERS	FINANCE	65.00
	*** TOTAL	FOR DEPT 13		83.20
	TARGET	SUPPLIES/DEAD WTR EVENT	COMMUNIC	50.25
	U.S. POSTMASTER	NEWSLETTER POSTAGE	COMMUNIC	383.40
	*** TOTAL	FOR DEPT 16		433.65
	CASTLE INSPECTION SVC	JAN&FEB BLDG INSPECTIONS	PLANNING	1,533.20
	CASTLE INSPECTION SVC	JAN&FEB PLUMBING INSPECT	PLANNING	74.40
	PAKOY, GENE	1ST QTR PYMT	PLANNING	605.25
	*** TOTAL	FOR DEPT 17		2,212.85
	HUGHES & COSTELLO	3/98 PROSECUTIONS	PROSECUT	2,238.25
	*** TOTAL	FOR DEPT 23		2,238.25
	AIRCRAFT RESCUE & FIRE	B. LEMAY FIRE FIGHTCOURS	FIRE FIG	65.00
	CARLA ASLESON	MISC SUPPLIES	FIRE FIG	1.03
	AMERICAN LINEN SUPPLY CO.	LINEN CLEANING	FIRE FIG	36.76
	CASH	UPS CHARGES	FIRE FIG	8.47
	EMERGENCY APPARATUS MAINT	OIL CHANGES 752,753,757	FIRE FIG	438.60
	EMERGENCY APPARATUS MAINT	REPAIRS 752,753,757	FIRE FIG	1,157.36
	FIRE EQUIPMENT SPECIALTIE	HELMET FACESHIELDS	FIRE FIG	41.95
	FIRE EQUIPMENT SPECIALTIE	SCBA TEST/MSA VALUE RPR	FIRE FIG	50.90

APPROVAL OF BILLS
 PERIOD ENDING: 3-19-98_

CHECK#	VENDOR NAME	DESCRIPTION	DEPT.	AMOUNT
35957	FIRE/EMS CENTER	1998 MN ST FIRE SHOOL	FIRE FIG	800.00
	JANKE, KATHLEEN	CLEANING FIRE DEPT	FIRE FIG	80.00
36010	KURHAJETZ, CLEM	MUTUAL AID DINNER	FIRE FIG	169.78
	OXYGEN SERVICE COMPANY	BREATING OZ	FIRE FIG	58.50
	USWEST COMMUNICATIONS	PHONE SVC 3-1	FIRE FIG	176.02
	YOU & ME	SWEATSHIRTS	FIRE FIG	340.00
	RAMSEY CO. FIRE CHIEFS	CHIEFS ANNUAL BANQUET	FIRE FIG	72.00
	*** TOTAL	FOR DEPT 24		3,496.37
35957	FIRE/EMS CENTER	1998 MN ST FIRE SCHOOL	FIRE PRE	100.00
	*** TOTAL	FOR DEPT 25		100.00
	BROWNING-FERRIS IND.	3/98 WASTE	CITY HAL	194.17
	CASH	KEYS	CITY HAL	7.46
	CHAMPION AUTO STORES	MOTOR OIL	CITY HAL	12.48
	CAPITAL SUPPLY COMPANY	TOILET REPAIR PARTS	CITY HAL	41.43
	CARE AIR CONDITIONING &	REPLACE FLAME SENSORS	CITY HAL	472.76
	KNOX LUMBER CO.	SWEEPING COMPOUND	CITY HAL	10.69
	LEAGUE OF MN CITIES	98 SAFETY/LOSS WORKSHOP	CITY HAL	15.00
	NSP	ELECT 3-3	CITY HAL	708.84
	NSP	GAS 3-3	CITY HAL	458.35
	OXYGEN SERVICE COMPANY	CYLINDER RENTALS	CITY HAL	9.00
	TWIN CITY GARAGE DOOR CO	RPR GARAGE DOOR LIFT	CITY HAL	140.21
	USWEST COMMUNICATIONS	PHONE SVC 3-1	CITY HAL	628.93
	*** TOTAL	FOR DEPT 31		2,699.32
	CASH	LICENSE TUBS ON VEHICLES	STREETS	27.00
	GOPHER STATE ONE-CALL	UTILITY CHECK	STREETS	1.75
	MIDWAY FORD ROSEVILLE	TOUCH UP PAINT FOR TRK	STREETS	4.98
	MN POLLUTION CONTROL	POLLUTION CK FEES 2 TRKS	STREETS	16.00
	TRUCK UTILITIES MFG CO.	RPR SWITH SNOW PLOW	STREETS	51.34
	PROVEN FORCE CLUTCH-U-JNT	NEW U-JOINTS F250 TRK	STREETS	151.95
	*** TOTAL	FOR DEPT 32		253.02
36009	BANK CARD CENTER-FBS	BILL & DON CONFERENCE	PARK & R	170.00
	CASH	CEDAR FOR WOOD DUCK HOUS	PARK & R	9.57
	ICMA RETIREMENT TRUST 457	3/98 TRETSVAN	PARK & R	100.00
	ICMA RETIREMENT TRUST 457	3/98 MAERTZ	PARK & R	100.00
	KNOX LUMBER CO.	WALL TRIM/ANGLE SASH	PARK & R	77.29
	NSP	ELECT/GAS 3-3	PARK & R	535.99
	NSP	ELECT 3-9	PARK & R	88.16
	NSP	ELECT 3-3	PARK & R	22.06
	SUPERIOR PRODUCTS MFG CO	SERVING UTENCILS/ETC	PARK & R	209.80
	USWEST COMMUNICATIONS	PHONE SVC 3-10	PARK & R	61.57
	*** TOTAL	FOR DEPT 41		1,374.44
	NSP	ELECT 3-1	STREET L	2,010.39
	NSP	ELECT 12/22 TO 3/6	STREET L	233.21
	*** TOTAL	FOR DEPT 54		2,243.60
	U.S. POSTMASTER	NEWSLETTER POST 1 PAGE	SOLID WA	54.77
	*** TOTAL	FOR DEPT 56		54.77
	J.O. THOMPSON INC.	CARPET OFFICE PUBLIC WKS	GENERAL	195.00

APPROVAL OF BILLS
 PERIOD ENDING: 3-19-98_

CHECK#	VENDOR NAME	DESCRIPTION	DEPT.	AMOUNT
*** TOTAL FOR DEPT 63				195.00
	HOWARD R GREEN COMPANY	HOYT AVE ENGINEERING	INFRASTR	105.00
*** TOTAL FOR DEPT 71				105.00
	KNOX LUMBER CO.	BATTERIES	SANITARY	18.67
	METROPOLITAN COUNCIL	4/98 SS CHARGES	SANITARY	23,675.83
	NSP	ELECT 3-9	SANITARY	11.42
	NSP	ELECT 3-3	SANITARY	15.42
	NSP	ELECT 3-6	SANITARY	105.17
*** TOTAL FOR DEPT 75				23,826.51
	E.M.S. LOGCON, INC.	CHIN STAPS	RESCUE S	180.00
	MICROFLEX	LATEX GLOVES	RESCUE S	77.50
	AIRTOUCH CELLULAR	3/98 CHARGES	RESCUE S	11.98
*** TOTAL FOR DEPT 76				269.48
	RAMSEY COUNTY	SPEICLA ASSESSMENT PACKT	LARPENTE	33.70
36013	KINKO'S	COPYING/BINDING EXP	LARPENTE	102.08
*** TOTAL FOR DEPT 82				135.78
	HOWARD R GREEN COMPANY	AUDIT INFOR	LINDIG S	42.50
*** TOTAL FOR DEPT 83				42.50
	BERNARDY, CONNIE LANNERS	3/16 TO 3/31 PROF SVCS	MCAD	1,227.13
	BERNARDY, CONNIE LANNERS	TELEPHONE EXP	MCAD	435.51
	BERNARDY, CONNIE LANNERS	OFFICE SUPPLIES	MCAD	224.75
	BERNARDY, CONNIE LANNERS	MEETINGS/CONFERENCES	MCAD	345.35
	BERNARDY, CONNIE LANNERS	COPY/PRINTING EXPS	MCAD	54.58
*** TOTAL FOR DEPT 84				2,287.32
*** TOTAL FOR BANK 01				51,361.18
*** GRAND TOTAL ***				51,361.18

b.

C H E C K R E G I S T E R

CHECK TYPE	CHECK DATE	EMPLOYEE NAME NUMBER	CHECK NUMBER	CHECK AMOUNT
COM	3 13 98	32 RAYMOND BROWN	28453	135.53
COM	3 13 98	34 CLEMENT KURHAJETZ	28454	60.15
COM	3 13 98	35 LEO LINDIG	28455	35.02
COM	3 13 98	40 KEVIN ANDERSON	28456	113.51
COM	3 13 98	42 MICHAEL D. CLARKIN	28457	185.86
COM	3 13 98	45 JAMES D. FULLER	28458	80.93
COM	3 13 98	47 NATHANIEL HEROLD	28459	6.47
COM	3 13 98	60 TERRY D. IVERSON	28460	13.80
COM	3 13 98	63 RACHELLE L. MARVIN	28461	28.14
COM	3 13 98	66 ALFRED HERNANDEZ	28462	54.14
COM	3 13 98	70 JUSTIN T. NOVAK	28463	104.07
COM	3 13 98	72 JOHN R. WOLFSBERGER	28464	96.16
COM	3 13 98	73 JEREMY HUTCHISON	28465	89.70
COM	3 13 98	74 MARK J. ALLEN	28466	81.21
COM	3 13 98	75 JOSEPH P. KRAJEWSKI	28467	46.98
COM	3 13 98	76 STEVEN M. HOY	28468	42.03
COM	3 13 98	77 BARBARA J. LEMAY	28469	50.51
COM	3 13 98	78 JON ERICHSON	28470	67.08
COM	3 13 98	1002 SUSAN HOYT TAFF	28471	1325.18
COM	3 13 98	1003 TERRY IVERSON	28472	1113.56
COM	3 13 98	1005 CAROL KRIEGLER	28473	646.88
COM	3 13 98	1007 PATRICIA PHILLIPS	28474	830.30
COM	3 13 98	1010 CARLA ASLESON	28475	1025.65
COM	3 13 98	1013 WILLIAM MAERTZ	28476	999.87
COM	3 13 98	1026 JASON CIERNIA	28477	103.89
COM	3 13 98	1033 DAVE TRETSVEN	28478	752.86
COM	3 13 98	1088 DONALD R. MEISSNER	28479	382.02
COM	3 13 98	1136 ROLAND O. OLSON	28480	834.06

COMPUTER CHECKS	9305.56
MANUAL CHECKS	.00
NOTICES OF DEPOSIT	.00

****TOTALS**** 9305.56

CONSENT
Meeting Date: 3/25/98
Item: 2

ITEM DESCRIPTION: Licenses

SUBMITTED BY: Pat Phillips, Licensing Coordinator

REVIEWED BY: Carla Asleson, AA/Planner

EXPLANATION/SUMMARY:

BUSINESS LICENSE

First Chiropractic #3680

ACTION REQUESTED: Approval

ITEM: Proposed text changes in the city's cooperative service policy to conform to legal practice

SUBMITTED BY: Carla Asleson, Administrative Assistant/Planner

REVIEWED BY: Susan Hoyt, City Administrator
Joel Jamnik, Attorney

EXPLANATION/DESCRIPTION:

Summary and Action Requested. The city council is asked to approve "housekeeping" language changes to the city's cooperative service policy. Most of these changes have been suggested by the city attorney and are not policy changes.

Goal 4: To provide a responsive and effective city government

Strategy 7: To effectively manage the city's financial resources

Attachment: Proposed changes to cooperative service policy

ACTION REQUESTED: Approve amendments to "Financial Support for Cooperative Service Policy"

J. FINANCIAL SUPPORT FOR COOPERATIVE SERVICE POLICY

1. PURPOSE

The city will consider expenditure requests for cooperative ventures with giving financial support to service organizations or projects which provide benefits and services to residents of the city.

2. POLICY

Must be an intergovernmental service or project.

The financial support should be proportional to population.

The financial support must be on-going or be part of an on-going effort with well-established goals and measurable results.

The service or project must be something that the city cannot accomplish by itself.

The service or project must meet the legal requirements and of promoting and ensuring the health, safety, and welfare of Falcon Heights citizens.

3. IMPLEMENTATION

In past years, the city has undertaken cooperative ventures with given financial support to the following:

Northwest Youth and Family Services Northwest Suburban Youth Services
Dispute Resolution Center
Mayor's Commission Against Drugs Mayor's Council Against Drugs
Share-A-Home Program
Retired Senior Volunteer Program
Roseville Senior Program
Family Violence Network

POLICY 1
Date: 3/25/98

ITEM DESCRIPTION: Consideration of Resolution 98-07 adopting the 1998 Larpenteur Avenue assessment roll

SUBMITTED BY: Terry Maurer, City Engineer

REVIEWED BY: Susan Hoyt, City Administrator
Carla Asleson, Administrative Assistant/Planner

EXPLANATION/DESCRIPTION:

Summary and Action Requested. Following the public hearing, a resolution needs to be passed adopting the assessment roll. If the council wishes to change an assessment amount on one or more properties, it must be done prior to the passage of the resolution.

Goal 2: To maintain and promote the assets of the city's unique neighborhoods, including commercial, residential, and open space uses for present and future generations.

Strategy 4: Maintaining the city's infrastructure.

Action Item: Implement scheduled street improvement projects.

ATTACHMENTS:

- Resolution 98-07, adopting the assessment roll
- Proposed assessment roll

ACTION REQUESTED: Adoption of Resolution 98-07.

No. 98-07

CITY OF FALCON HEIGHTS

C O U N C I L R E S O L U T I O N

Date: March 25, 1998

RESOLUTION ADOPTING ASSESSMENT OF 1998 LARPENTEUR AVENUE
IMPROVEMENT PROJECT

WHEREAS, pursuant to proper notice duly given as required by law, the city council of the City of Falcon Heights has met and heard and passed upon all objections to the proposed assessments for the 1998 improvements of Larpenteur Avenue; and

WHEREAS, the properties proposed to be assessed include the following property parcels abutting Larpenteur Avenue between Cleveland Avenue and Snelling Avenue:

16-29-23-33-0002 through 16-29-23-33-0003
16-29-23-34-0018 through 16-29-23-34-0022
16-29-23-34-0026 through 16-29-23-34-0027
16-29-23-34-0073 through 16-29-23-34-0074
16-29-23-34-0086 through 16-29-23-34-0090
16-29-23-44-0023
21-29-23-11-0001 through 21-29-23-11-0002
21-29-23-11-0024
21-29-23-12-0002 through 21-29-23-12-0008

NOW THEREFORE, BE IT RESOLVED BY THE CITY COUNCIL OF FALCON HEIGHTS, MINNESOTA:

The city finds that each parcel of land named in the assessment is benefitted by the proposed improvements in the amount of the assessment the city proposed to levy against it in the assessment.

The city accepts the assessment and levies a special assessment against each parcel of land named in the assessment in the amount in the assessment.

The special assessment shall be payable in equal annual installments of principal extending over a period of ten (10) years. The special assessment shall bear interest at a rate of seven percent (7%) per annum from the date of this resolution. The first installment of principal shall be due and payable on or before the first Monday in the first January following the date of this resolution, together with interest which has accrued through December 31 of the preceding year.

Each owner of property that is subject to this special assessment may, at any time before certification of the assessment to the county auditor, pay to the city the principal amount plus accrued interest then owing, providing the city shall not charge interest if the entire assessment is paid within thirty (30) days of the date of this resolution. At any time on or before November 15 of each year in which the assessment is outstanding, a property owner may prepay the assessment by paying to the city an amount equal to the principal then outstanding, plus interest through December 31 of the year in which the property owner prepays. Any prepayment made after November 15 must include interest through December 31 of the following year.

The city directs the city clerk to transmit a certified copy of this resolution to the county auditor for Ramsey County, with instructions to extend the assessment on the appropriate tax lists of the county, and collect and pay over to the city the assessment in the same manner as other municipal taxes.

Adopted by the city council of the City of Falcon Heights this 25th day of March, 1998.

Moved by: _____

GEHRZ ___ In Favor
GIBSON TALBOT
HUSTAD ___ Against
JACOBS
KUETTEL

Approved by: _____

Mayor
March 25, 1998
Date

Attested by: _____

City Clerk
March 25, 1998
Date

Assessment Roll
1998 Larpenteur Ave
Construction Project
Ten Year Assessment
7% Interest

City of Falcon Heights
Proposed 1998 Special Assessments

Owner Name	Owner Address	PIN Number	Frontage	Category	Assessment
City of Falcon Heights	2077 W. Larpenteur Avenue, Falcon Heights, MN 55113	16-29-23-33-0002	213.48	TE	\$11,207.70
City of Falcon Heights	2077 W. Larpenteur Avenue, Falcon Heights, MN 55113	16-29-23-33-0003	123.00	TE	\$6,457.50
Cleon & Elaine Garley	P.O. Box 436, Stillwater, MN 55082	16-29-23-34-0018	115.62	R	\$3,063.93
Cleon & Elaine Garley	11040 Otchipwe Avenue North, Stillwater, MN 55082	16-29-23-34-0019	110.00	R	\$2,915.00
Rollin & Marilyn Gates	1865 W. Larpenteur Avenue, Falcon Heights, MN 55113	16-29-23-34-0020	61.86	R	\$1,639.29
Richard Putnam	1867 W. Larpenteur Avenue, Falcon Heights, MN 55113	16-29-23-34-0021	75.00	R	\$1,987.50
Joyce Gimmestad	1871 W. Larpenteur Avenue, Falcon Heights, MN 55113	16-29-23-34-0022	56.57	C	\$1,979.95
Arthur & Carol Lindig	1875 W. Larpenteur Avenue, Falcon Heights, MN 55113	16-29-23-34-0026	78.15	R	\$2,070.98
Michael & Carrie Doody	1300 Ingerson Road, Arden Hills, MN 55112	16-29-23-34-0027	75.00	R	\$1,987.50
Richard & B.H. Carter	1957 W. Larpenteur Avenue, Falcon Heights, MN 55113	16-29-23-34-0073	60.00	R	\$1,590.00
Elizabeth Ann McKay	1907 W. Larpenteur Avenue, Falcon Heights, MN 55113	16-29-23-34-0074	71.00	R	\$1,881.50
Grace W. Lai	2129 Scudder Street, St. Paul, MN 55108	16-29-23-34-0086	15.38	R	\$407.57
Grace W. Lai	2129 Scudder Street, St. Paul, MN 55108	16-29-23-34-0087	15.38	R	\$407.57
Grace W. Lai	2129 Scudder Street, St. Paul, MN 55108	16-29-23-34-0088	15.38	R	\$407.57
Grace W. Lai	2129 Scudder Street, St. Paul, MN 55108	16-29-23-34-0089	15.38	R	\$407.57
Christopher Lai	1881 W. Larpenteur Avenue, Falcon Heights, MN 55113	16-29-23-34-0090	15.38	R	\$407.57
Phillip & Gretchen Dorn	1687 W. Larpenteur Avenue, Falcon Heights, MN 55113	16-29-23-44-0023	72.00	R	\$1,908.00
Harvest States Cooperatives	1667 N. Shelling Avenue, Falcon Heights, MN 55108	21-29-23-11-0001	150.00	C	\$5,250.00
Harvest States Cooperatives	Box 64594, St. Paul, MN 55164	21-29-23-11-0002	100.00	C	\$3,500.00
Harvest States Cooperatives	Box 64594, St. Paul, MN 55164	21-29-23-11-0024	160.00	C	\$5,600.00
Carol Sagstetter	2407 Reimond Avenue, Little Canada, MN 55117	21-29-23-12-0002	107.50	R	\$2,848.75
Boyco, Inc.	1788 N. Albert Street, Falcon Heights, MN 55113	21-29-23-12-0003	141.43	R	\$3,747.90
Boyco, Inc.	1788 N. Albert Street, Falcon Heights, MN 55113	21-29-23-12-0004	141.43	R	\$3,747.90
Hermes Land Company	1750 W. Larpenteur Avenue, Falcon Heights, MN 55113	21-29-23-12-0005	141.43	C	\$4,950.05
Hermes Land Company	1750 W. Larpenteur Avenue, Falcon Heights, MN 55113	21-29-23-12-0006	141.43	C	\$4,950.05
Hermes Land Company	1750 W. Larpenteur Avenue, Falcon Heights, MN 55113	21-29-23-12-0007	158.26	C	\$5,539.10
Sidal Realty Company	6760 Walker Street, St Louis Park, MN 55426	21-29-23-12-0008	330.00	R	\$8,745.00

TOTAL

\$89,605.45

POLICY 2
Date: 3/25/98

ITEM: Update on the city costs for phase II of the Larpenteur Avenue street reconstruction being done by Ramsey County

SUBMITTED BY: Dan Soler, Ramsey County

REVIEWED BY: Susan Hoyt, City Administrator

EXPLANATION/DESCRIPTION:

Summary, no action requested. The county received bids for the second phase of the Larpenteur road reconstruction project. The costs are \$112,701 higher than estimated at \$104,442 for the city partly because the federal share dropped from 80% to 52%, but more importantly because the stormsewer costs were much higher than expected – estimated at \$54,866 and actual \$150,367. The city covers 100% of the costs from local sources. The total cost for the construction portion of the work will be \$186,456 out of the city's Larpenteur funds and \$30,969 out of the city's Municipal State Aid (MSA) funds that come directly from the state. The administrator estimated the local contribution out of the Larpenteur funds for this phase of the street project at \$154,000. The county is proceeding with the project and will charge the city according to the contract.

ATTACHMENT

1 Memo from Dan Soler, Project Engineer

ACTION REQUESTED:

No action required.

p. 2



Department of Public Works

Paul L. Kirkwold, P.E., Director and County Engineer

ADMINISTRATION/LAND SURVEY

50 West Kellogg Blvd., Suite 910

St. Paul, MN 55102 • (612) 266-2600 • Fax 266-2615

ENGINEERING/OPERATIONS

3377 N. Rice Street

Shoreview, MN 55126

(612) 484-9104 • Fax 482-5232

March 9, 1998

Ms. Susan Hoyt
City Administrator
City of Falcon Heights
2077 West Larpenteur Avenue
Falcon Heights, Minnesota 55113

Dear Susan:

Enclosed for your review and information is a cost breakdown of the local fund split and Municipal State Aid split for the reconstruction of Larpenteur Avenue between Cleveland Avenue and Snelling Avenue. The Federal participation was capped at 52.42% on this project. The total amount of federal funds available to all Larpenteur projects was \$4,000,000.00. Subsequent projects will utilize County State Aid, Municipal State Aid and local funds.

Thank you for your continued cooperation on this project. If you have any questions please feel free to give me a call.

Sincerely,

Daniel E. Soler
Project Manager - Larpenteur Avenue

Enc.



GROUP 2

In this group the estimated Municipal State Aid participation was 15%. Because curb and trees are eligible for County State Aid Highway funding, Ramsey County made up the difference between actual (52.42%) federal funds and estimated (80%) federal funds with County State Aid Highway funds.

ENGR EST	
FED	80.00%
CSAH	5.00%
MSAH	15.00%
100.00%	

CONTRACT	
FED	52.42%
CSAH	32.58%
MSAH	15.00%
100.00%	

ITEM NO.	ITEM	UNIT	TOTAL QUANTITY	QUANTITY THIS GROUP	ENGR. UNIT PRICE	AMOUNT
2531.501	CONCRETE CURB & GUTTER DES B624	m	4714	2473	\$23.78	\$8,821.19
2571.541	TRANSPLANT TREE (150 mm CAL. DECIDUOUS)	TREE	3	4	\$500.00	\$300.00
2571.541	TRANSPLANT TREE (150 mm CAL. CONIFEROUS)	TREE	4	4	\$500.00	\$300.00
2571.541	TRANSPLANT TREE (1 m HT. CONIFEROUS)	TREE	4	3	\$500.00	\$225.00
						<u>\$9,646.19</u>

BID UNIT PRICE	AMOUNT
\$28.87	\$10,709.33
\$195.00	\$117.00
\$175.00	\$105.00
\$195.00	\$87.75
<u>\$11,019.08</u>	

GROUP 3

The cost split for the traffic signal at Gortner Avenue is 50% County - 50% City after the application of Federal funds. With the federal funds limited to 52.42% this leaves 23.79% City and 23.79% County.

ENGR EST	
FED	80.00%
CSAH	10.00%
FH LOCAL	10.00%
100.00%	

CONTRACT	
FED	52.42%
CSAH	23.79%
FH LOCAL	23.79%
100.00%	

ITEM NO.	ITEM	UNIT	TOTAL QUANTITY	QUANTITY THIS GROUP	ENGR. UNIT PRICE	AMOUNT
2565.511	FULL T. ACT T. CONTROL SIGNAL SYSTEM C	SIG SYS	1	1	\$137,800.00	\$13,780.00
						<u>\$13,780.00</u>

BID UNIT PRICE	AMOUNT
\$101,000.00	\$24,027.90
<u>\$24,027.90</u>	

GROUP 4

The cost split for the traffic signal at Fairview Avenue is 75% County - 25% City after the application of Federal funds. With the federal funds limited to 52.42% this leaves 11.90% City and 35.68% County.

ENGR EST	
FED	80.00%
CSAH	15.00%
FH LOCAL	5.00%
100.00%	

CONTRACT	
FED	52.42%
CSAH	35.68%
FH LOCAL	11.90%
100.00%	

ITEM NO.	ITEM	UNIT	TOTAL QUANTITY	QUANTITY THIS GROUP	ENGR. UNIT PRICE	AMOUNT
2565.511	FULL T. ACT T. CONTROL SIGNAL SYSTEM D	SIG SYS	1	1	\$139,900.00	\$6,995.00
						<u>\$6,995.00</u>

BID UNIT PRICE	AMOUNT
\$101,100.00	\$12,030.90
<u>\$12,030.90</u>	

GROUP 5

In this group the estimated Municipal State Aid participation was 20%. Because sidewalk and EVP are eligible for County State Aid Highway funding, Ramsey County made up the difference between actual (52.42%) federal funds and estimated (80%) federal funds with County State Aid Highway funds.

ENGR EST	
FED	80.00%
CSAH	0.00%
MSAH	20.00%
100.00%	

CONTRACT	
FED	52.42%
CSAH	27.58%
MSAH	20.00%
100.00%	

ITEM NO.	ITEM	UNIT	TOTAL QUANTITY	QUANTITY THIS GROUP	ENGR. UNIT PRICE	AMOUNT
2521.501	100 mm CONCRETE WALK	m ²	7869	4263	\$19.37	\$16,514.86
2565.601	EMERGENCY VEHICLE PREEMPTION SYSTEM C	LS	1	1	\$6,600.00	\$1,320.00
2565.601	EMERGENCY VEHICLE PREEMPTION SYSTEM D	LS	1	1	\$6,600.00	\$1,320.00
						<u>\$19,154.86</u>

BID UNIT PRICE	AMOUNT
\$20.45	\$17,435.67
\$5,530.00	\$1,106.00
\$5,680.00	\$1,136.00
<u>\$19,677.67</u>	

NOTE: ENGR EST. QUANT. THIS GROUP = 4213

GROUP 6

This group resulted in the biggest change from the original estimate. The County estimated the cost share at 50% Federal, 25% County and 25% City. The actual cost split, as determined by the MN/DOT Hydraulics Unit, is 28.83% Federal, 26.17% County and 45% City. Also; the original estimate did not include all the items which were included in the bid, elements were added to the storm sewer design after the estimate was prepared. This included additional work at the Fairgrounds Pond.

ENGR EST	
FED	50.00%
CSAH	25.00%
FH LOCAL	25.00%
100.00%	

CONTRACT	
FED	28.83%
CSAH	26.17%
FH LOCAL	45.00%
100.00%	

ITEM NO.	ITEM	UNIT	TOTAL QUANTITY	QUANTITY THIS GROUP	ENGR. UNIT PRICE	AMOUNT
	STORM SEWER	LS	1	1	\$219,465.42	\$54,866.36
						<u>\$54,866.36</u>

BID UNIT PRICE	AMOUNT
\$334,217.14	\$150,397.71
<u>\$150,397.71</u>	

NOTE: STORM SEWER ITEM INCLUDES MULTIPLE PAY ITEMS

GRAND TOTAL	FH LOCAL	\$75,641.36	\$186,456.51
	MSAH	\$28,801.05	\$30,696.75
		<u>\$104,442.41</u>	<u>\$217,153.26</u>

ITEM: Consideration of an assessment rate for streetlights on Hoyt Avenue west of Cleveland

SUBMITTED BY: Susan Hoyt, City Administrator

REVIEWED BY: Terry Maurer, City Engineer

EXPLANATION/DESCRIPTION:

Summary and action requested. The council is being asked to consider and approve an assessment rate for the 13 new streetlights that are being installed on Hoyt Avenue west of Cleveland as part of the St. Paul street improvement project. The 13 lights are required to complete the lighting design and security pattern along this stretch of Hoyt. These streetlight fixtures are more expensive than those paid for by the city in the neighboring streets in the Grove neighborhood. The proposed assessment rate for discussion of \$ 15.92 per front foot is based on the estimated cost of the new streetlights and their installation (\$42,287) after a 'credit' (\$1,561/existing streetlight) is given for the estimated cost of replacing the current nine lights with the same streetlight standards located in the rest of the neighborhood to the north. Falcon Heights property owners notified of this project expressed an interest in having these St. Paul style streetlights in place even though an assessment would be associated with them. The city of St. Paul assesses about \$4.30 per front foot for streetlights because much of the cost for streetlights is paid for by the city and not the abutting property owners.

Meets goal2: To maintain the assets of the city's unique neighborhoods.

Strategy 4: To maintain the city's infrastructure.

Action item: To implement street improvement projects.

Meets goal 4: To provide a responsive and effective city government.

Strategy 7: To effectively manage the city's financial resources.

Background.

Streetlights on reconstructed streets in Falcon Heights. The city maintains the streetlights on local streets. The streetlights are typically located on overhead power poles at key intersections and along midpoints of long blocks where it is possible to place them. When streets are reconstructed the lighting pattern and fixtures are maintained. Adding new style streetlights with each street reconstruction project is not standard with city reconstruction projects and it would increase the cost of the street reconstruction projects for the city and

property owners. In the past, property owners have not requested streetlights as part of the street reconstruction work.

Streetlights in the Grove. The streetlights in the Grove neighborhood are different than in the rest of the city because the university owned and maintained the neighborhood until 1979 after which the Grove was turned over to Falcon Heights. After being turned over to Falcon Heights in 1979 until the mid-1980's the city assessed Grove property owners for the power costs and maintenance of the streetlights even though this was inconsistent with city policy in other neighborhoods. The streetlights in most of the neighborhood were put in by the university as stand alone streetlights not attached to power poles because the location of the power poles made it difficult to do. However, this west of Burton Street on Hoyt Avenue, the streetlights are located on power poles at the corner of the intersections. In 1988 the city installed stand alone streetlights along many of the streets to replace the worn out streetlights in the Grove. (The lights were constantly burning out.) At this time the city considered trying to locate new streetlights on existing power poles, but could not because of the extensive tree growth and the location of the power poles to the rear of the properties. The stand alone poles in the neighborhood were the least expensive lighting of this type provided by NSP in 1988.

In 1995 the city replaced five aging, stand alone streetlight standards along Folwell Avenue east of Coffman Street with seven of the NSP stand alone streetlights because they were a continuing maintenance problem and no replacement parts were available. The property owners were not assessed for replacing the existing lights. The entire project cost was \$10,928 for streetlights and installation by NSP.

The Grove neighborhood has never had the opportunity to participate with St. Paul in purchasing these St. Paul style streetlights prior to the 1998 Hoyt project being initiated by St. Paul.

Streetlights along this section of Hoyt Avenue. There are five tall stand alone streetlights east of Burton Street along Hoyt Avenue. These fixtures would probably need replacing over the next 10 or so years because they date back to the other fixtures that the city has replaced over time. There are four overhead lights on power poles at the four street corners east of Burton Street. These would probably not require replacing over the next 10 years.

Proposed streetlighting plan with the reconstruction of Hoyt Avenue. Many neighborhoods in St. Paul do not have any residential streetlights. Therefore, the city of St. Paul puts in streetlights in all of its residential reconstruction projects. St. Anthony Park, the neighborhood adjacent to the Grove, does have these lights, but the southside of Hoyt street does not. St. Paul plans to put 13 of these streetlights along the northside of Hoyt Avenue west of Cleveland and 13 along

the southside to create a residential lighting effect. There are currently no streetlights on the southside of Hoyt Avenue. In order to create the appropriate level of lighting and to provide aesthetic consistency throughout the streetfront, St. Paul wants Falcon Heights to have these lights installed along the northside of Hoyt.

Property owners along Hoyt Avenue. The city held one meeting with property owners along Hoyt about the proposed plan for the street and the lights. All property owners received a summary of the meeting and a follow-up letter last week stating the plan to install these lights with a possible assessment. At the meeting, the city staff said that the assessment might be as high as \$25 a front foot because these lights are more expensive than other streetlights in the area and that it is not city policy to pay for these streetlights in its neighborhoods. The property owners that spoke with city staff wanted the streetlights provided by St. Paul.

TURN TO NEXT PAGE

Some Assessment Options to consider:

Cost of 13 new streetlights \$42,287 \$3,252/light

Cost of 7 NSP streetlight /installation in 1995 \$10,928 \$1,561/light (basis for credit)

Assessment area (includes U of M) 1,780 assessable front feet
(assessable lots vary from 60 ft. to 78 ft. with U of M at 2100 ft.)

Options	Cost	total credit	net cost	Asses/ff	estimate for 70 foot lot
1 no credit	\$42,287	0	\$42,287	\$23.76	\$1,663
2 credit for 5 lights that would need replacement	\$42,287	\$7,805	\$34,482	\$19.37	\$1,356
3 credit for existing 9 lights	\$ 42,287	\$14,049	\$ 28,238	\$15.86	\$ 1,110
4 credit for all new 13 lights	\$ 42,287	\$20,293	\$ 21,994	\$12.36	\$ 865

(St. Paul assesses about \$4.30 per front foot and covers some costs through city funds.)

For discussion purposes, staff suggests using option number 2, giving some credit for lights that are in place today and are an on-going part of the city's maintenance and replacement responsibilities, but not absorb the costs for all the new fixtures since there is added benefit from these residential style of lights and this lighting pattern and it isn't consistent with city policy to replace this type of streetlighting pattern in street reconstruction projects.

Street reconstruction costs and proposed assessments. The total project cost for street work is estimated at \$185,061 for Falcon Heights with streetlights at \$42,287 this is \$227,348. An estimated fourteen of the twenty three property owners along Hoyt will be assessed for the street reconstruction because they were not assessed for the street work done in 1993. The proposed rate will be \$26.50 per front foot. Property owners along Hoyt were assessed for sidewalk

replacement in 1993 at a cost of \$800 per lot. The plans do not require sidewalk removal at this time. (St. Paul will probably assess property owners about \$25.00 per front foot for the street work).

ATTACHMENTS:

- 1 Map of Grove (note Hoyt Avenue)
- 2 List of addresses and assessment frontage (using short side for a corner lot)
- 3 Proposed light standard
- 4 Proposed costs for streetlights

ACTION REQUESTED:

Discuss the options for paying for the streetlights as a portion of the Hoyt Avenue reconstruction project.

Move to adopt an assessment rate to use in notifying property owners so they are prepared for the assessment notices.

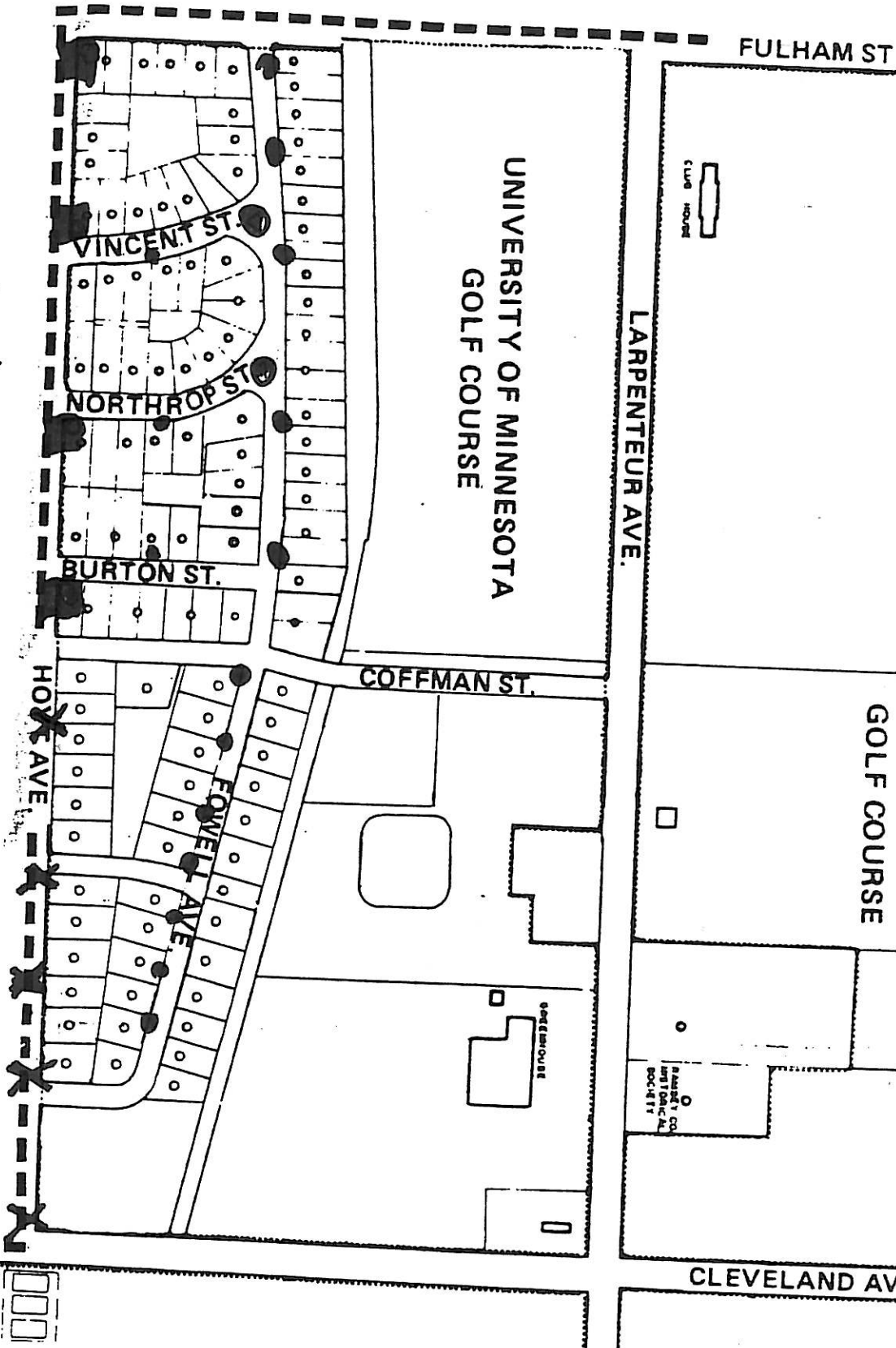

- on NSP poles
- X on stand alone
- Stand alone (1 never lights)
- in drive 1988/1995

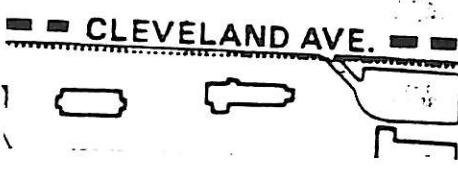

1998 Hoyt Avenue Assessments

Property Address	PIN Number	Front Footage	Street Assessment	Streelight Assessment	Total Assessment	Notes on Street Assessment
2100 Larpenteur Avenue	20-29-23-11-0239	250.00	0.00		0.00	
2099 Hoyt Avenue	20-29-23-11-0038	95.00	\$2,517.50		\$2,517.50	
2105 Hoyt Avenue	20-29-23-11-0039	78.00	\$2,067.00		\$2,067.00	
2111 Hoyt Avenue	20-29-23-11-0040	78.00	\$2,067.00		\$2,067.00	
2117 Hoyt Avenue	20-29-23-11-0041	78.00	\$2,067.00		\$2,067.00	
2123 Hoyt Avenue	20-29-23-11-0042	78.00	\$2,067.00		\$2,067.00	
2129 Hoyt Avenue	20-29-23-11-0043	72.00	\$1,908.00		\$1,908.00	
2135 Hoyt Avenue	20-29-23-11-0024	73.45	\$1,946.43		\$1,946.43	
2141 Hoyt Avenue	20-29-23-11-0065	74.00	\$1,961.00		\$1,961.00	
2147 Hoyt Avenue	20-29-23-11-0064	74.00	\$1,961.00		\$1,961.00	
2153 Hoyt Avenue	20-29-23-11-0063	74.00	\$1,961.00		\$1,961.00	
2159 Hoyt Avenue	20-29-23-11-0028	70.00	\$1,855.00		\$1,855.00	
2165 Hoyt Avenue	20-29-23-11-0029		\$0.00		\$0.00	Assessed for Coffman
1564 Burton Street	20-29-23-12-0079		\$0.00		\$0.00	Assessed for Burton
2203 Hoyt Avenue	20-29-23-12-0073		\$0.00		\$0.00	Assessed for Burton
2225 Hoyt Avenue	20-29-23-12-0060		\$0.00		\$0.00	Assessed for Northrop
2243 Hoyt Avenue	20-29-23-12-0057		\$0.00		\$0.00	Assessed for Northrop
1564 Vincent Street	20-29-23-12-0044		\$0.00		\$0.00	Assessed for Vincent
2271 Hoyt Avenue	20-29-23-12-0038		\$0.00		\$0.00	Assessed for Vincent
2279 Hoyt Avenue	20-29-23-12-0039	60.00	\$1,590.00		\$1,590.00	
2285 Hoyt Avenue	20-29-23-12-0040	60.00	\$1,590.00		\$1,590.00	
2291 Hoyt Avenue	20-29-23-12-0041	60.00	\$1,590.00		\$1,590.00	
1564 Fulham Street	20-29-23-12-0025		\$0.00		\$0.00	Assessed for Fulham
TOTAL			\$27,147.93		\$27,147.93	

*Consolidated for Larpenteur
Low 2 parcel*

SINGLE LANTERN STYLE LIGHT STANDARD DETAIL LANTERN TYPE L-10

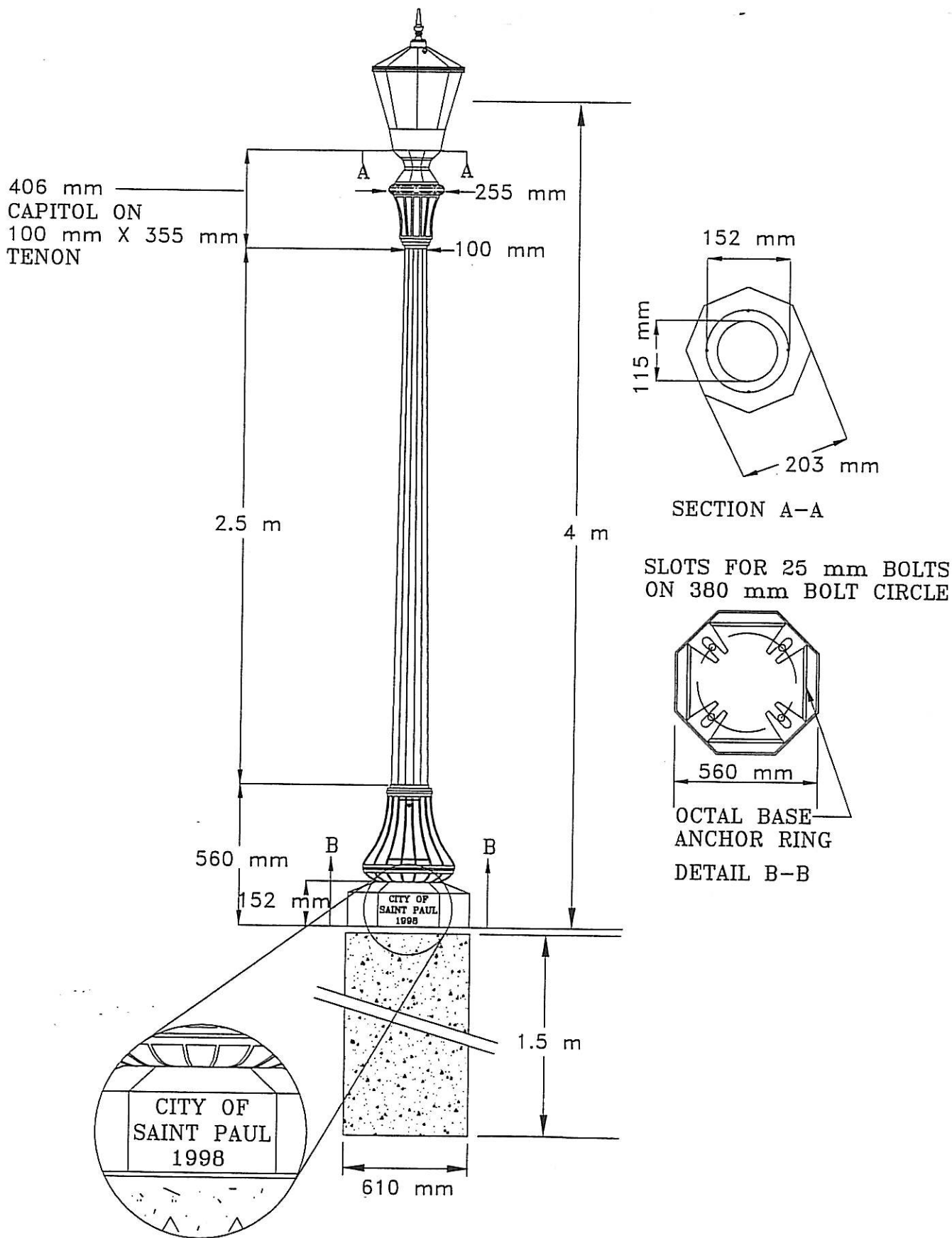

Mar 04, 1998

DEPARTMENT OF PUBLIC WORKS
CITY OF ST. PAUL

HOYT AVE.-FALCON HEIGHTS
STREET LIGHTING SYSTEM
CITY PROJ. NO. 98-P-8105

ENGINEERS ESTIMATE

SPEC. AND/OR BID ITEM NUMBER	ITEM	UNIT	CONTRACT QUAN.	UNIT PRICE ESTIMATE	CONTRACT PRICE ESTIMATE
2545.602	REMOVE LIGHT FOUNDATION	EACH	5	\$260.00	\$1,300.00
2545.602	REMOVE AND SALVAGE LIGHT UNIT	EACH	5	\$200.00	\$1,000.00
2545.602	LIGHT STANDARD TYPE L10	EACH	13	\$860.00	\$11,180.00
2545.602	LUMINAIRE TYPE R100	EACH	13	\$520.00	\$6,760.00
2545.602	LIGHT BASE FOUNDATION TYPE ST	EACH	13	\$350.00	\$4,550.00
2545.602	PULL BOX TYPE L	EACH	3	\$270.00	\$810.00
2545.602	SERVICE PANEL LIGHTING	EACH	1	\$1,300.00	\$1,300.00
2545.603	38 mm NMC BEHIND CURB	METER	802	\$4.59	\$3,681.18
2545.603	50 mm NMC TRENCH & RESTORE/PUSH	METER	2	\$16.40	\$32.80
2545.603	1C#6 AWG	METER	2,202	\$1.33	\$2,928.66
2545.603	1C#8 BARE	METER	802	\$0.87	\$697.74

ESTIMATE SUBTOTAL	\$34,240.38
E&I (18.5%)	\$6,334.47
MISCELLANEOUS (5%)	\$1,712.02
ESTIMATE TOTAL	\$42,286.87
ESTIMATED COST PER UNIT	\$3,252.84

Falcon Heights portion only

ITEM: Resolution receiving feasibility report and calling for hearing on the 1998 improvement of Hoyt Avenue (west of Cleveland Avenue)

SUBMITTED BY: Terry Maurer, City Engineer

REVIEWED BY: Susan Hoyt, City Administrator
Carla Asleson, Administrative Assistant/Planner

EXPLANATION/DESCRIPTION.

Summary and Action Requested: The City of St. Paul is proceeding with plans to reconstruct streets in the St. Anthony Park neighborhood, including Hoyt Avenue. The City of Falcon Heights will participate financially in this project because Hoyt Avenue is the street that forms the border between the two cities.

The council is asked to approve the attached resolution, which receives the feasibility report from the City of St. Paul and establishes a public hearing on the improvement for April 22, 1998.

Goal 2: To maintain and promote the assets of the city's unique neighborhoods, including commercial, residential, and open space uses.

Strategy 4: Maintaining the city's physical infrastructure.

Action Item: Implement scheduled street improvement projects

Attachments:

1. Letter from the City Engineer
2. Resolution 98-08

ACTION REQUESTED:

Adoption of Resolution 98-08, receiving the feasibility report and calling a public hearing on the improvement for April 22, 1998.

CITY OF FALCON HEIGHTS

C O U N C I L R E S O L U T I O N

Date: March 25, 1998

RESOLUTION RECEIVING FEASIBILITY REPORT AND CALLING PUBLIC HEARING
THE 1998 HOYT AVENUE IMPROVEMENT

WHEREAS, a report has been prepared with reference to the improvement of Hoyt Avenue between Cleveland Avenue and Fulham Street, and this report was received by the city council on March 25, 1998.

NOW, THEREFORE, BE IT RESOLVED BY THE CITY COUNCIL OF FALCON HEIGHTS, MINNESOTA:

1. The council will consider the improvement of such street in accordance with the report and the assessment of abutting property for all or a portion of the cost of the improvement pursuant to Minnesota Statutes Chapter 429 at an estimated total cost to the city of \$227,287.00.
2. A public hearing shall be held on such improvement on the 22nd day of April, 1998 in the council chambers of the city hall on or after 7:00 p.m. and the clerk shall give mailed and published notice of such hearing and improvement as required by law.

Adopted by the council this 25th day of March, 1998.

Moved by: _____

GEHRZ ___ In Favor
GIBSON TALBOT
HUSTAD ___ Against
JACOBS
KUETTEL

Approved by: _____

Mayor
March 25, 1998
Date

Attested by: _____

City Clerk
March 25, 1998
Date

POLICY 5
Date: 3/25/98

ITEM: Update on the petition for the Capital Region Watershed District from the Board of Water and Soil Resources (BWSR)

SUBMITTED BY: Susan Hoyt, City Administrator

EXPLANATION/DESCRIPTION:

Summary, no action requested. In response to the council action at the February 25, 1998 council meeting, the attached letter was sent to Mr. Ronald Harnack, the executive director of BWSR for the public record for the hearing that is set for April 6, 1998. A copy of the minutes from the meeting will also be sent to BWSR for the public record. In addition the staff has firmer figures on the market value and tax capacities of the three watersheds under discussion.

These are:

	Central	Southwest	Central/ Southwest	Ramsey Washington	All three combined
1998 taxable market value	3,102,524,800	3,597,357,300	6,699,882,100	5,216,375,050	11,916,257,150
tax capacity for calculating 1998 local tax rates	51,195,316	58,799,422	109,994,738	80,526,466	190,521,204

ATTACHMENTS:

- 1 Letter from city to BWSR for public record
- 2 Notice of public hearing



CITY OF
FALCON HEIGHTS

2077 W. LARPEUR AVENUE FALCON HEIGHTS, MN 55113-5594 PHONE (612) 644-5050 - FAX (612) 644-8675

16 March 1998

Mr. Ronald Harnack
Executive Director
Board of Water and Soil Resources
Suite 200
One West Water Street
St. Paul, Minnesota 55107

RE: Comments for the public hearing on the Central Ramsey Watershed petition

Dear Mr. Harnack:

Although the city of Falcon Heights represents a small percentage of the geographic area in the Central Ramsey watershed and the Southwest Ramsey watershed, these two watersheds comprise over seventy-five per cent of the city's land area and ninety-five per cent of its population. Therefore, the city is very interested in the outcome of the petition process initiated by the St. Paul District 10 Community Council requesting that the Central Ramsey watershed become a watershed district. Because this is an important issue to Falcon Heights citizens, the city council is forwarding its position on the petition to become part of the public record. In sum, the city supports combining these two watersheds into an independent watershed district for four reasons. First, to provide a more effective organization for managing water quality in these multi-jurisdictional watersheds; second, to focus the new district's mission on improving water quality in a fully developed, well established urban environment; third, to maximize citizen representation and access to the board of managers governing this new watershed district by guaranteeing that all five managers will be appointed from and represent the interests of the Central Ramsey and Southwest Ramsey watersheds; and fourth, to assure property owners that any property taxes that are levied and collected by the new watershed district will only be used to benefit properties in the Central Ramsey and Southwest Ramsey watersheds. The city does not support merging the Central Ramsey watershed (and the Southwest Ramsey watershed) with the Ramsey Washington Watershed District because

HOME OF THE MINNESOTA STATE FAIR AND THE U OF M INSTITUTE OF AGRICULTURE



PRINTED ON RECYCLED PAPER

it believes that this organization could not be as responsive and accountable to the citizens' needs in these watersheds as a smaller, independent watershed district.

The city of Falcon Heights adopted this position after it discussed the pending petition for the Central Ramsey watershed at two council meetings. At the first meeting on February 25, 1998, councilmembers learned about the issue from the information provided by several resource people including representatives from BWSR, St. Paul District 10, the Central Ramsey WMO, and the Ramsey Board of Soil and Water Conservation. At the second meeting on the topic, the city council determined that water quality in the Central Ramsey and Southwest Ramsey watersheds will be best served through a watershed district rather than by continuing the existing water management organizations. However, given that a watershed district is another level of government, the city wants to assure its citizens that the watershed district will focus on the issues of paramount concern to them such as the conditions of nearby Como Lake and the Gottfried Pit. Therefore, the city believes that consolidating these fully developed watersheds into the Ramsey Washington Watershed District, even with its acknowledged commitment to and success in dealing with water management issues, would not be in the best interest of the citizens of Falcon Heights. Combining with the Ramsey Washington Watershed District would require balancing the needs of the very urbanized Central and Southwest Ramsey watersheds with the needs of the developed and developing Ramsey Washington watershed.

Furthermore, as an elected body of representatives, the city council has a keen appreciation for citizens' need to access their elected and appointed officials at every level of government. The council also knows that the information that citizens provide their representatives is critical to resolving issues and establishing new directions for any organization. Given the importance of access to government, the city believes that the five appointed managers to the watershed district board must be as representative and as committed to the Central Ramsey and Southwest Ramsey watersheds as possible. Therefore, it is important to have the board of managers be appointed by the Ramsey County Board directly from the citizens of the Central Ramsey and Southwest Ramsey watersheds to achieve maximum representation on and access to the board of managers. With this governance model there would be no confusion as to whose interests the board of managers is appointed to serve. This contrasts with the model of combining the Central Ramsey watershed with the Ramsey Washington Watershed District which would place the newly appointed Central Ramsey (and Southwest Ramsey) managers as a minority on the established watershed district board for a minimum of one year. It would also require having citizens from the Central Ramsey (and Southwest Ramsey) fit into an established citizen advisory framework that may not be as open to making the issues related to Central Ramsey (and Southwest Ramsey) watershed (s) its priority.

However, access to government is not only important for citizens who want to be involved in creating and implementing a plan for improved water quality in the Central Ramsey and Southwest Ramsey watersheds. It is also important for making sure that the board of managers is accounting for how and where the property tax dollars levied and collected from property owners in the Central Ramsey and Southwest Ramsey

watersheds are being spent. The board of managers of a new district would be responsible for levying and collecting taxes that will directly and only benefit property owners in the Central Ramsey and Southwest Ramsey watersheds and not for activities undertaken in watersheds that don't directly benefit the properties from which the taxes are generated. Furthermore, if citizens feel that these property taxes are being misdirected, they can influence the appointments to the board of managers through the Ramsey County board members who they elect every four years. Merging the Central Ramsey watershed (and Southwest Ramsey watershed) with the Ramsey Washington Watershed District would significantly reduce accountability for citizens of the Central Ramsey (and Southwest Ramsey) watersheds.

Finally, the city recognizes that if an independent watershed district is formed for the Central Ramsey and Southwest Ramsey watersheds that the newly appointed board of managers would be responsible for determining the administrative structure for the independent watershed district. However, the city encourages the board of managers to use the existing expertise and resources within Ramsey County to assist with planning whenever it is possible to do so.

Thank you for receiving these comments as part of the public record. I will be happy to respond to any questions that you may have prior to or at the April 6, 1998 public hearing.

Sincerely,



Susan Hoyt
City Administrator

- c:
- Mayor and Councilmembers, City of Falcon Heights
 - Ms. Janice Rettman, Ramsey County Commissioner
 - Mr. Michael Perniel, Chair, District 10 Community Council
 - Ms. Susan Schmidt, District 10, Central Ramsey WMO
 - Mr. Jay Benanav, City of St. Paul, Councilmember
 - Mr. Jim Reiter, City of St. Paul, Councilmember
 - Ms. Anne Weber, City of St. Paul Public Works, Central Ramsey WMO
 - Mr. Karl Keel, City of Roseville, Central Ramsey WMO
 - Mr. Ken Haider, City of Maplewood, Central Ramsey WMO
 - Mr. Bill Downing, Falcon Heights resident
 - Mr. Joe Fox, Chair, Ramsey Board of Soil and Water Conservation
 - Mr. Steve Woods, Montgomery Watson Engineering
 - Mr. Jerry Hammer, Minnesota State Fair
 - Mr. Ray Jackson, University of Minnesota

**NOTICE OF PUBLIC HEARING
CAPITOL REGION WATERSHED DISTRICT ESTABLISHMENT
or
RAMSEY-WASHINGTON METRO WATERSHED DISTRICT ENLARGEMENT/INCREASE NUMBER OF
MANAGERS**

**Minnesota Board of Water and Soil Resources
One West Water Street, Suite 200
St. Paul, Minnesota 55107**

In the matter of the petition for the establishment of the Capitol Region Watershed District or the enlargement/increase number of managers of the Ramsey-Washington Metro Watershed District (RWMWD) pursuant to Minn. Statutes Sections 103D.205, 103D.221, 103D.261, and 103D.305.

Whereas, the subject petition dated January 20, 1998 has been filed with the Department of Property Records and Revenue (auditor) of Ramsey County, the Commissioner of the Department of Natural Resources (DNR), the Director of the DNR Division of Waters, and the RWMWD, pursuant to Minn. Statutes Sections 103D.205 and 103D.261.

Now therefore, the Board of Water and Soil Resources (Board) hereby issues the following:

NOTICE IS HEREBY GIVEN that a public hearing on the establishment/enlargement/increase number of managers of a watershed district will be held on Monday, April 6, 1998, beginning at 7:00 PM at the Como Lakeside Pavilion at Como Park, 1360 N. Lexington Pkwy, St. Paul, Minnesota.

The purpose of the hearing is to receive public comments on the establishment of a watershed district or the enlargement and increase in the number of managers of the RWMWD in the areas of the Central and Southwest Ramsey Watershed Management Organizations pursuant to the Metropolitan Surface Water Management Act, Minn. Statutes Sections 103B.205 to 103B.255. At the hearing, all interested persons will be given opportunity to submit pertinent information.

The proposed watershed district or enlargement encompasses approximately 37 square miles of land in Ramsey County. It includes land in the cities of St. Paul, Roseville, Maplewood, and Falcon Heights, the State Fairgrounds, and the University of Minnesota. The RWMWD includes land in the cities of Landfall, Little Canada, Maplewood, North St. Paul, Oakdale, St. Paul, Vadnais Heights, White Bear Lake and Woodbury.

The purpose for the establishment or enlargement of the watershed district and contemplated improvements is to conserve the natural resources of the state by land use planning, flood control, and other conservation projects by using sound scientific principles for the protection of the public health and welfare and the provident use of the natural resources.

For further information contact Jim Haertel of the Board at 297-2906.

Dated in St. Paul, Minnesota this 4th day of March, 1998.

s/Jim Haertel
Water Management Specialist

ITEM: Consideration of 1998 volunteer recognition activities

SUBMITTED BY: Carla Asleson, Administrative Assistant/Planner

REVIEWED BY: Susan Hoyt, City Administrator

EXPLANATION/DESCRIPTION:

Summary and Action Requested. Decide on a way of recognizing community volunteers for Minnesota Volunteer Recognition Week (April 19 - April 25).

Goal 3: To expand opportunities for the interaction and involvement of citizens of all ages in their neighborhoods and community.

Action Item: Recognition of volunteers

Past Recognition of Volunteers. The city council has recognized its volunteers in a number of ways over the years. Activities in the past have included formal activities, such as a recognition dinner, to more informal methods, such as letters of thanks sent by the Mayor. Last year, each commissioner was sent a letter of thanks from the Mayor or a Councilmember, along with a "Falcon Heights Volunteer" t-shirt. In addition, each volunteer was sent tickets for treats at the summer ice cream social, where a group volunteer photo was taken. The cost for these activities was \$657 (\$92 for the photo and \$565 for the shirts, with extra shirts ordered.)

Ideas for 1998. The following are some ideas that the council might consider for 1998 recognition. Many are methods that other cities use to recognize their volunteers.

- Sit-down dinner
About 1/2 of the cities responding to a survey last year hold a dinner every year or every other year. At the 1996 dinner, 18 of the 60 invited volunteers attended the event, along with guests and staff.

A catered buffet meal at city hall for 60 people would cost approximately \$550 (\$7.50 per person x 60 + \$100 for decorations and incidentals like napkins.) If every volunteer attended and brought a guest, the cost would be approximately \$1,000 (\$7.50 per person x 120 + \$100).
- Recognition picnic with sub sandwiches

- Treat/snack reception
- Certificates of appreciation/letters of thanks
- Small gifts, such as "Key to the City" pins, coffee mugs, insulated lunchbags or tote bags. These items can be purchased for about \$5.00 each, including tax and shipping (see attachments for examples of volunteer gifts)
- Group photo at the Ice Cream Social, published in the fall newsletter

Budget. The 1998 budget includes \$650.00 for volunteer recognition. This works out to about \$10 per volunteer. If the council opts for a reception or a dinner, funding should be allowed for each volunteer to bring a guest.

ACTION REQUESTED: Discuss recognition activities and direct staff on desired actions.

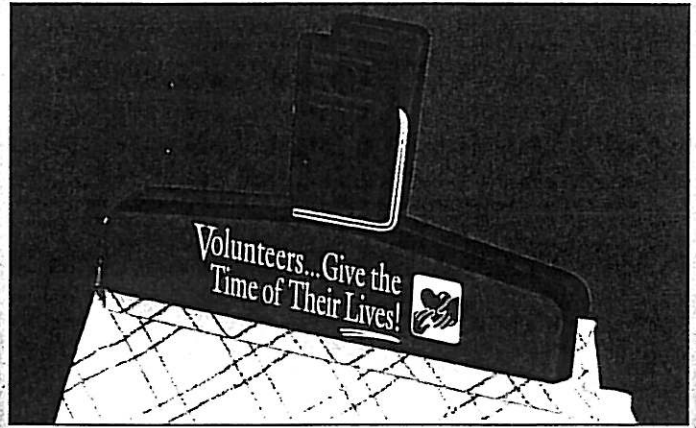

#MBA80316 - BAG & MEMO APPRECIATION CLIP

Your volunteer's memory of you will stay as fresh and enjoyable as the snacks they seal. These clips can also be used for coupons, papers and memos. Size: 4"

Price:

25-99: 85¢ ea. 1000+: 60¢ ea.
 100-249: 75¢ ea. Less than minimum: 95¢ ea.
 250-999: 68¢ ea.

Nurses
 Helping, 
 Sharing Always Caring!

VOLUNTEER AND NURSE APPRECIATION TOTE BAGS

This high quality, large-sized canvas tote is the perfect carrying vehicle. Available with choice of two slogans, 'Volunteers Give The Time of Their Lives' or 'Nurses... Helping, Sharing, Always Caring' on front. Size: 14-1/2" x 13" x 3"

#MBA80303 - Volunteer Tote

#MBA80304 - Nurses Tote

Prices: (Styles may be combined)

10-24: \$5.95 ea.
 25-99: \$5.75 ea.
 100-499: \$5.55 ea.
 500+: \$5.35 ea.
 Less than minimum: \$6.95 ea.

IDEAL FOR...
 National Nurses Week



VOLUNTEER AND NURSE APPRECIATION MEMO BOARDS

Never forget another appointment with this write-on/wipe-off memo board. Four magnets on back make hanging easy.

Includes special pen. Available with slogans of appreciation for either nurses or volunteers.

#MBA80276 -

Volunteers...The Heart of Our Program™ Heart Memo Board
 Size: 8-1/2" x 8-1/2"

#MBA80277 -

Nurses...Helping, Sharing, Always Caring™ Apple Memo Board. Size: 6-1/2" x 10"

Prices: (Styles may be combined)

10-49: \$1.95 ea.
 50-249: \$1.85 ea.
 250-999: \$1.75 ea.
 1000+: \$1.65 ea.
 Less than minimum: \$2.25 ea.

GIFTS OF APPRECIATION

VOLUNTEER AND NURSE APPRECIATION COMPACT MIRROR

This handy personal mirror has a sleek contemporary design, fits easily in pocket or purse and is virtually indestructible. Available with choice of two slogans, either 'Volunteers...Give the Time of Their Lives' or 'Nurses...Helping, Sharing, Always Caring!'. Individually packaged. Size: 2-1/4" x 2-1/4"

- #MBA80290 - Volunteers Compact Mirror
- #MBA80291 - Nurses Compact Mirror

Prices: (Styles may be combined)

25-49: \$1.45 ea. 250-999: \$1.30 ea.
 50-249: \$1.40 ea. 1000+: \$1.20 ea.
 Less than minimum: \$1.50 each

ERRORS
 gn, fits
 available
 time of
 ing.

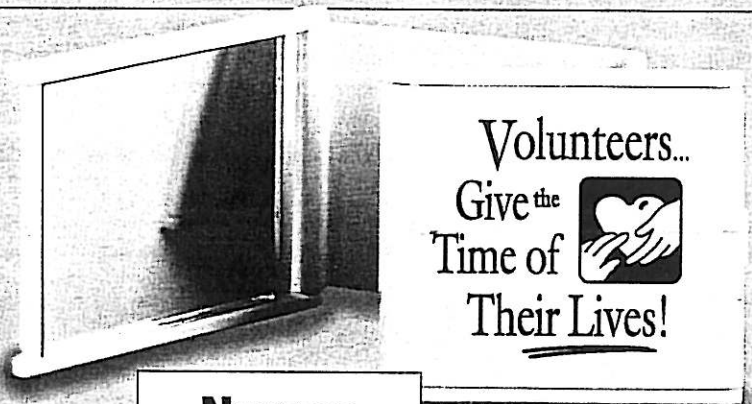

Nurses
 Helping, Sharing, Always Caring!
 (Logo: two apples)

IDEAL FOR...
 National Nurses Week



VOLUNTEER & NURSE INSULATED LUNCH BAGS

For every day use, these high quality nylon insulated lunch bags will keep sandwiches and snacks cool and fresh. Insulated to keep in the cold, these lunch bags are velcro tabbed to keep food in and with your choice of two slogans, the lunch bag will be remembered and appreciated by those who are special to you. Size: 6-1/2" x 9" x 4-1/2"

- #MBA80364 - Volunteers Insulated Lunch Bag
- #MBA80365 - Nurses Insulated Lunch Bag

Prices: (Styles may be combined)

10-49: \$4.95 ea.
 50-249: \$4.75 ea.
 250-999: \$4.55 ea.
 1000-2499: \$4.40 ea.
 2500+: \$4.25 ea.
 Less than minimum: \$5.45 ea.

Nurses
 Helping, Sharing, Always Caring!
 (Logo: two apples)

IDEAL FOR...
 National Nurses Week



#MBA80289 - VOLUNTEER APPRECIATION LETTER SLITTER

Here's a gift everyone needs. This letter slitter will open any envelope swiftly and neatly without damaging the contents. Available with slogan 'Volunteers Give the Time of Their Lives!'.

Prices: (Must be ordered in increments of 25)

25-49: \$1.50 ea. 500-999: \$1.35 ea.
 50-149: \$1.45 ea. 1000+: \$1.30 ea.
 150-499: \$1.40 ea. Less than minimum: \$1.75 each





#MBA80317 - VOLUNTEERS MICROFOIL APPRECIATION BALLOON
 What better way to say 'thank-you, you're appreciated' than with these 18" heart-shaped foil balloons. Each balloon offers the message 'Volunteers Give The Time of Their Lives!'. Suitable for helium or air inflation.

Prices:
 25: \$2.50 ea. 250: \$2.00 ea. Less than minimum:
 50: \$2.40 ea. 500: \$1.80 ea. \$3.00 ea.
 100: \$2.20 ea. 1000+: \$1.60 ea.

#MBA80318 - FESTIVE CELEBRATION BALLOONS
 These colorful 11" balloons are the perfect way to create a celebration atmosphere. Available with the slogan, "Thank You Volunteers!", these high quality balloons are ideal for both air and helium inflation.

Prices: (Must be ordered in increments of 25)
 25: 45¢ ea. 250: 30¢ ea.
 50: 40¢ ea. 500: 28¢ ea.
 100: 35¢ ea. 1000+: 25¢ ea.

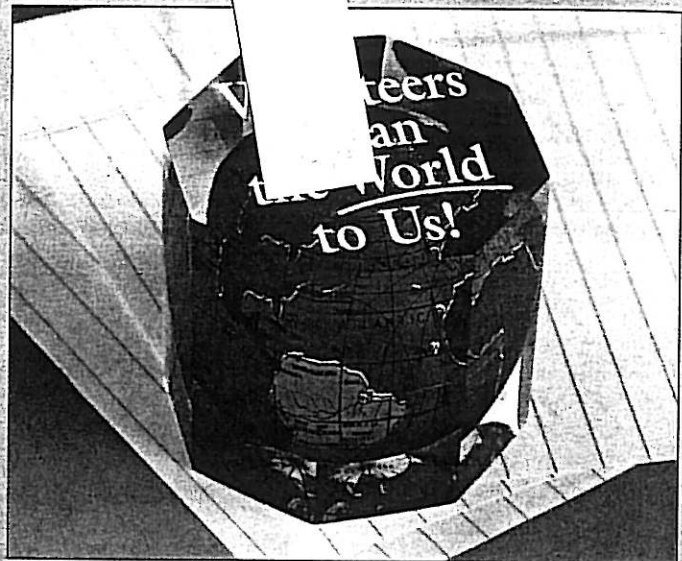

#MBA80273 - ACRYLIC, GLOBE-IN-CUBE PAPERWEIGHT
 This handsome gift says 'Volunteers Mean The World To Us' and features a beautiful, full-color globe imbedded in the clear acrylic cube. Makes the perfect addition to any desk. Size: 1-3/4" x 1-3/4"

Prices:
 10-49: \$4.50 ea. 250-999: \$3.95 ea. Less than minimum:
 50-249: \$4.25 ea. 1000+: \$3.45 ea. \$4.95 ea.

CERAMIC APPRECIATION MUGS
 Say thank you with these special ceramic mugs. Either slogan 'Volunteers Give The Time of Their Lives' or 'Our Program Is Special... Thanks To You' on the front of this value-priced, high quality mug offers your sentiment of appreciation.

#MBA80293 - Volunteers Give The Time of Their Lives" Mug
 #MBA80294 - Our Program Is Special...Thanks To You" Mug

Prices: (Must be ordered in increments of 12, styles may be combined)
 12: \$4.65 ea.
 24: \$4.45 ea.
 48: \$4.25 ea.
 144: \$4.05 ea.
 288: \$3.95 ea.
 576+: \$3.75 ea.
 Less than minimum:
 \$5.25 ea.

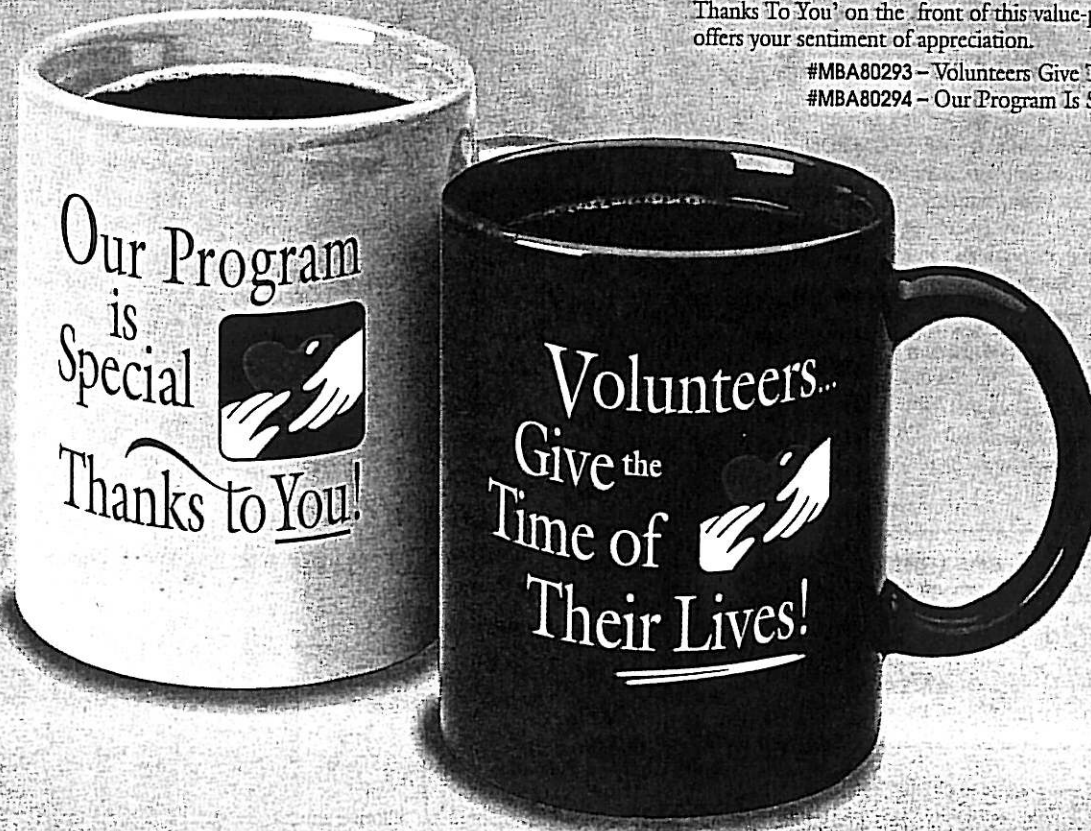

ITEM: Consideration of request from Dispute Resolution Center to provide funding for a cooperative service venture

SUBMITTED BY: Tim Hedeem, Dispute Resolution Center

REVIEWED BY: Susan Hoyt, City Administrator
Carla Asleson, Administrative Assistant/Planner

EXPLANATION/DESCRIPTION:

Summary and Action Requested. The city council has been asked to make a lawful expenditure to the Dispute Resolution Center of \$500 to aid in their annual operations. The request is in conformance with the city's "Financial Support for Cooperative Service" policy. The center provided direct mediation services for six residents/businesses in 1997 and provided referral services to three others. The center requests a fee from participants, although there is a sliding fee scale in the case of financial need. The fee is \$25.00 per party per mediation session for individuals and \$75.00 per party per session for businesses. No one is turned away due to an inability to pay the fee.

There is \$1,946.00 remaining in the budget for expenditures of this type after commitments to four other organizations (Northwest Youth & Family Services, North Suburban Senior Council, Minnesota Senior Federation, and RSVP) are honored.

Goal 4: To provide a responsive and effective city government
Strategy 7: To effectively manage the city's financial resources

Background. The Dispute Resolution Center (DRC) handles mediation requests for parties throughout the area. Mediation is appropriate when two parties disagree on an issue but agree to have their dispute heard by a neutral third party. A mediator gets the parties to listen to each other's viewpoint and to come to a mutually satisfactory conclusion. DRC's mediators do not have legal decision-making rights.

In 1997, DRC handled six mediation cases involving Falcon Heights residents or businesses. These cases included two property disputes between customers and merchants, a breach of contract case (an agreement for services was not honored), two landlord/tenant cases (security deposits; noise levels), and one custody/visitation issue. DRC also provided assistance to another three residents by referring them to more appropriate services.

Funding Request. DRC is requesting that the city consider directing funds to their organization. While any amount would be appreciated, the suggested donation for a city of Falcon Heights' size is \$500.00

Conformance to City's Cooperative Service Policy.

The city's Cooperative Service Policy contains five criteria for organizations requesting funds.

Must be an intergovernmental service or project.

DRC provides services to residents of Falcon Heights and other residents of the eastern metro area. It receives funding from a number of suburban cities, as well as the City of St. Paul, Ramsey County, and the State of Minnesota. Approximately 45% of DRC's budget is obtained through cooperative ventures with cities, counties, and the state.

The financial support should be proportional to population.

The suggested funding amount of \$500 is based upon Falcon Heights' size as a city of less than 10,000.

The financial support must be on-going or be part of an on-going effort with well-established goals and measurable results.

Dispute Resolution Center has been in existence for several years and is able to provide quantitative results in the form of number of clients served.

The service or project must be something the city cannot accomplish by itself.

Due to limited staff, mediation is not a service that the city can provide. In addition, DRC occasionally provides mediation service where one of the players in the dispute is the city.

The service or project must meet legal requirements and promote and ensure the health, safety, and welfare of Falcon Heights citizens.

The health, safety, and welfare of citizens is enhanced when DRC diffuses conflict between citizens, avoiding the escalation of hostilities between people.

Conclusion

Dispute Resolution Center meets the criteria to receive funds through the city's cooperative service policy and it has provided services to Falcon Heights citizens. This means that the city council may award funding, although they are not obligated to do so.

DRC was not specifically budgeted to receive funds in 1998. There is \$1,946.00 remaining in the budget for unspecified funding requests after four other commitments have been honored (Northwest Youth & Family Services, North Suburban Senior Council, Minnesota Senior Federation, and RSVP.)

ATTACHMENT: Letter from Tim Hedeem, Dispute Resolution Center

ACTION REQUESTED: Discuss DRC's request and determine if payment is appropriate.



Dispute Resolution
Center

265 Oneida Street
St. Paul, MN 55102
612.292.7791
fax: 612.298.5729

March 6, 1998

Susan Hoyt, City Administrator
City of Falcon Heights
2077 W. Larpenteur Avenue
Falcon Heights, MN 55113-5594

Dear Ms. Hoyt,

In 1997, the Dispute Resolution Center handled mediation cases involving **6 Falcon Heights residents or businesses**. Additionally, the D.R.C. provided assistance to **another 3 residents** by directing them to more appropriate services for their issues.

Cities like Falcon Heights realize a high return on their investment in the services of the Dispute Resolution Center. The mediation or facilitation of community issues serves to reduce staff time and resources expended by the police, council members, city inspectors, and other officials. Cases referred to the Center save time and money, and often prevent later problems that could demand city action—including costly litigation.

Please recall that we are always available to make presentations to your city staff—law enforcement, social services, and other departments often make effective use of our mediation services to address difficult issues among constituents—just call Janeen Massaros, Director of Mediation Services at 292-7791 to set up an appointment or to receive additional copies of our brochures.

I write today to request that Falcon Heights make a 1998 contribution to the Dispute Resolution Center for our continued services to your city. For those cities that are precluded by local policy from making contributions, the Center would be glad to explore contract arrangements. While contributions or contracts of any size are appreciated, the following scale indicates annual donations made by cities similar to Falcon Heights:

population under 10,000	\$ 500
population of 10,000 - 20,000	1,000
population of 20,000 - 30,000	1,500
population of 30,000 - 50,000	2,000
population over 50,000	2,500

Thank you for your consideration of this request, and thank you for your support of our services. Please do not hesitate to contact me at 292-7791 if I can be of further assistance.

Yours very truly,

Timothy Hedeem
Executive Director

ITEM: Change in Solid Waste Commission Meeting Plans

SUBMITTED BY: Sam Jacobs, Councilmember

EXPLANATION/DESCRIPTION:

Summary and action requested. Over the past two years the role of the solid waste commission has changed. Originally charged with implementing and promoting recycling throughout the city, this service is now routine. Given this, the commission decided that it no longer needs to meet on a regular basis, but will remain ready to serve at the council's request. Three commissioners attended the meeting where this change in role was discussed. However, all commissioners were provided with copies of the minutes for their information and opportunity to react.

Meets goal # 4: To provide an effective and responsive city government.

ATTACHMENTS:

- 1 Minutes from Solid Waste Commission meeting of March 12, 1998
- 2 Guidelines for the Solid Waste Commission established by the city council

ACTION REQUESTED:

Discussion
Accept change in role

M E M O R A N D U M

DATE: March 13, 1998
TO: Solid Waste Commissioners
FROM: Carla Asleson, Staff Liaison
RE: Commission meeting of March 12, 1998
CC: Sam Jacobs, Susan Hoyt

Monthly Meetings Discontinued

At the March 12, 1998 commission meeting, the members present decided that it would be appropriate to discontinue meeting on a monthly basis. The city council does not have any solid waste/recycling issues awaiting the commission's attention and none are foreseen for the immediate future. Please see the enclosed draft meeting minutes for more information on this discussion.

The Solid Waste Commission's future will be discussed at the March 25, 1998 city council meeting. If you have questions, comments or concerns about this, please contact me at 644-5050 (daytime) or Sam Jacobs at 646-8717 (evening).

A Note From Carla

It's really been a pleasure getting to know each of you. It's such a treat to work with people who care so much about their community! Please consider volunteering your time and talents to the city in another capacity -- there are opportunities on the Park and Recreation Commission and also on the committee planning for the city's 50th birthday party celebration. Give me a call if you want more information about either of these groups.

MINUTES
CITY OF FALCON HEIGHTS
SOLID WASTE COMMISSION MEETING
March 12, 1998

DRAFT

PRESENT

Barbara Leary
Frank Meah
Barbara O'Leary

ABSENT

Jeff Alexander
Catherine Mackiewicz
Susan Smith

ALSO PRESENT

Carla Asleson, Staff Liaison
Sam Jacobs, Council Liaison

CALL TO ORDER

The meeting convened at 7:05 p.m., although there was not a quorum of members present and therefore no official business could occur.

DISCUSSION OF COMMISSION'S MISSION AND FUTURE DIRECTION

Councilmember Sam Jacobs led a discussion about the Solid Waste Commission's mission and future direction. He told the commissioners that he was not speaking on behalf of the city council but as an individual councilmember who had served as the staff liaison for several years.

Jacobs noted that when the city council first established the Solid Waste Commission, there was a lot of work to be done to establish a new recycling program and to pass ordinance changes related to garbage collection. The commission has recently struggled to find activities now that the recycling program is running smoothly. Jacobs indicated that the city council has been very pleased with the commission's past work but does not currently have any solid waste related items needing their attention. Jacobs asked the commissioners to consider whether the commission had fulfilled its mission and if so, whether it is appropriate to continue the commission in its present form.

Barbara Leary asked how other commissions handle meetings when there are no items for discussion. Carla Asleson answered that the Planning Commission and Park and Recreation Commission meet monthly, but the meetings are canceled when there are no agenda items for consideration. The Human Rights Commission now exists in an "on-call" status and meets only when there is a specific task to be undertaken.

Councilmember Jacobs stated that he placed this item on the agenda to generate discussion and not necessarily to promote dissolving the commission. If the commissioners feel that there are solid waste related issues that need to be addressed, the commission should certainly address them.

The commissioners present discussed the issue and determined that it did not make sense to continue meeting on a monthly basis when there are no solid waste and recycling issues awaiting consideration. They suggested that the commission could begin meeting again in the future if conditions changed and the city council saw the need to have input on an item.

Councilmember Jacobs thanked the commissioners for their past efforts and successes. He also encouraged them to consider volunteering for the city in other capacities, such as the Park and Recreation Commission or the committee organizing the city's 50th birthday party celebration.

ADJOURNMENT

The meeting was adjourned at 7:50 p.m.

Respectfully submitted,

Carla Asleson
Acting Recording Secretary

D. SOLID WASTE COMMISSION

1. Purpose. The purpose of the commission is to guide and plan for current and future abatement and handling of solid waste materials in the city. This is to ensure a safe, pleasant and economical environment for the city.
2. Composition & Qualifications. The commission shall consist of not less than seven nor more than nine members to be appointed by the mayor and approved by the council as follows:
 - a. Members of the commission shall be appointed according to their ability to contribute to and perform the functions, powers and duties imposed upon the commission.
 - b. The majority of the members shall be residents of Falcon Heights.
3. Terms, Vacancies, Oaths. The term of office of all commission members shall be three years. Except for appointments to fill a vacancy, an appointment in any year shall be deemed effective as of January 1 of such year for purposes of computing the term. No member shall serve more than two consecutive three year terms.

Members shall hold office until their successors are appointed. All members shall serve without compensation, but may be reimbursed for expenses as authorized and approved by the city council.
4. Removal. Commission members shall be subject to removal for cause, by a four-fifths vote of the city council. Failure to attend meetings regularly shall be one basis for removal.
5. Organization, Officers. Each commission shall elect a chairperson from among its appointed members for a term of one year. The commission shall appoint a secretary from among its members and may create and fill such other offices as determined necessary.
6. Meetings, Records, Reports. The commissions shall hold scheduled meetings, not less than one per calendar quarter. They shall adopt rules for the transaction of business and shall keep written public records of resolutions, recommendations and findings. On or before February 15 of each year, the commissions shall submit to the council work reports for the preceding calendar year.

7. Commission's Duties. In fulfillment of its purpose the commission's duties and responsibilities shall be to:
 - a. recommend community objectives and policy
 - b. make recommendations regarding the handling of solid waste within the city
 - c. review all matters relating or affecting current and future handling of solid waste within the city
 - d. draft and recommend for adoption regulations and additions or amendments to the code authorizing and empowering the enforcement of its findings relating to issues of solid waste within the city
 - e. serve as a forum for citizen involvement, and
 - f. develop and implement programs to raise the public's understanding of the problems created by solid waste and the opportunities of solution.